

# B38P

## High flow filter/regulator (stainless steel)

### 1/4 NPT, 3/8 NPT, G1/4 or G3/8

High flow filter/regulator designed for use in corrosive environment

Metallic parts meet NACE\* Standard MR-01-75

Applications include marine environment, oil and gas productions

\* National Association of Corrosion Engineers – recognised oil-field recommendation for resistance to sulphide stress cracking common in well-head and other corrosive environments

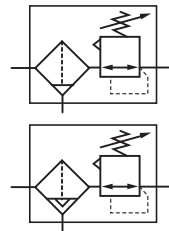

#### Technical features

##### Medium:

Compressed air only

##### Maximum inlet pressure:

31 bar (manual drain)

17 bar (autodrain)

##### Outlet pressure range:

0,5 ... 10 bar

##### Flow:

40 dm<sup>3</sup>/s

##### Element:

5, 25 or 40 µm

##### Port sizes:

1/4 NPT, 3/8 NPT, G1/4 or G3/8

1/4 PTF (gauge) and

1/4 NPT (automatic drain)

##### Drain:

Manual or automatic

Automatic drain operation conditions (float operated):

To close: > 0,3 bar,

To open: < 0,2 bar

Minimum air flow required to close 1 dm<sup>3</sup>/s

##### Fluid/Ambient temperature:

-20 ... +80°C (FKM seals)

-40 ... +80°C (NBR seals)

Air supply must be dry enough to avoid ice formation at temperatures below +2°C.

##### Materials:

Body, bowl, bonnet, filter element and adjusting screw:

316 stainless steel

Elastomers: FKM or NBR

#### Technical data, standard model, relieving and panel nut

Symbol	Port size	Outlet pressure *1) (bar)	Element (µm)	Flow *2) (dm <sup>3</sup> /s)	Drain	Weight (kg)	Model
	1/4 NPT	0,5 ... 10	5	40	Manual	1,61	B38P-254-B1MA
	3/8 NPT	0,5 ... 10	5	40	Manual	1,60	B38P-354-B1MA
	1/4 NPT	0,5 ... 10	5	40	Automatic	1,74	B38P-254-A1MA
	3/8 NPT	0,5 ... 10	5	40	Automatic	1,73	B38P-354-A1MA

\*1) Outlet pressure can be adjusted to pressures in excess of, and less than, those specified. Do not use these units to control pressures outside of the specified ranges.

\*2) Typical flow with 10 bar inlet pressure, 6,3 bar set pressure and a 1 bar drop from set.

#### Option selector

B38P-★4-★M★

Port size *	Substitute
1/4"	2
3/8"	3
Temperature range	Substitute
-20 ... +80°C (FKM seals)	5
-40 ... +80°C (NBR seals)	4





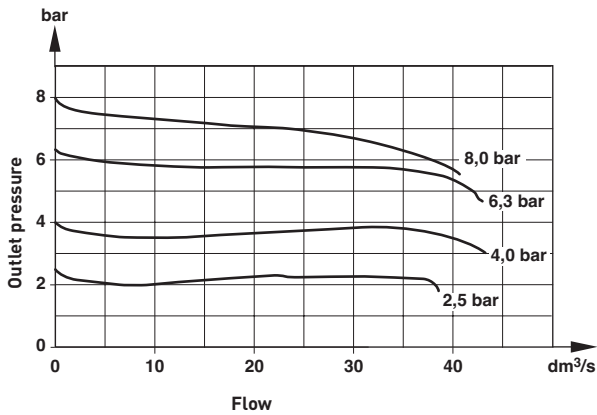
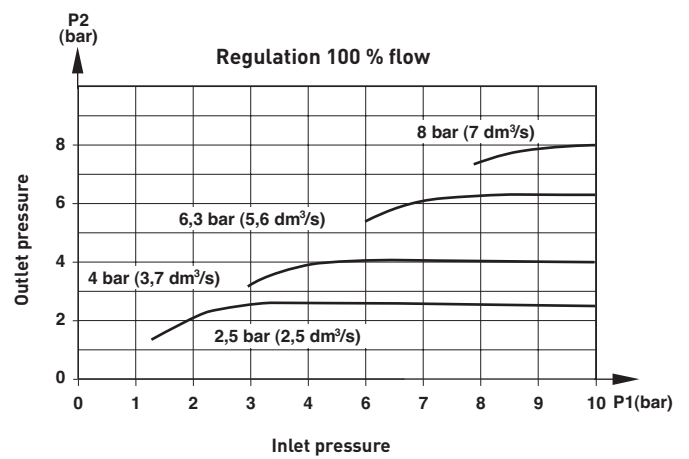
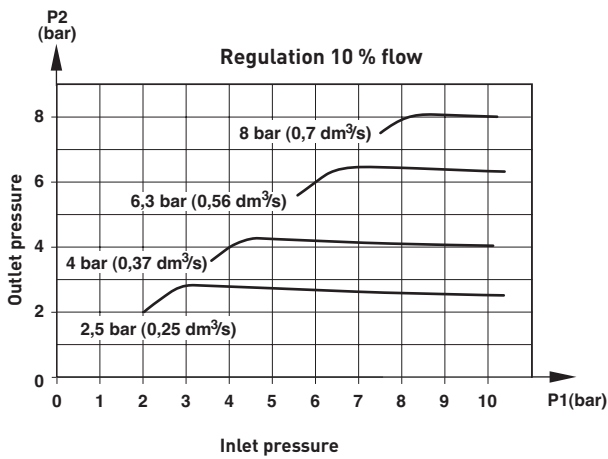

\* 1/2" port size on request

Thread form	Substitute
NPT	A
ISO G parallel	G
Element	Substitute
5 µm	1
25 µm	2
40 µm	3
Drain	Substitute
Automatic	A
Manual short bowl	B

**Flow characteristics**

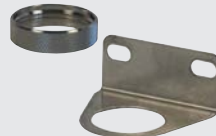
Inlet pressure: 10 bar, filter element: 5 µm, port size: 1/4 NPT



**Regulating characteristics**

**Accessories**

Panel nut	Neck mounting bracket	Neck mounting bracket	Gauge *	Plastic adjusting knob	Filter element	Service kit
						
5988-02	5989-02	18-001-973 (includes panel nut)	18-013-913 (0 ... 6 bar, -40 ... 65°C) 18-013-909 (0 ... 10 bar, -40 ... 65°C)	74630-04	5984-01 (5 µm) A080874-02 (25 µm) A080874-03 (40 µm)	A080823-01 (manual drain (FKM)) A080823-03 (manual drain (NBR)) A080823-02 (auto drain (FKM)) A080823-04 (auto drain (NBR))

\* Stainless steel items not strictly to NACE standard MR-01-75.

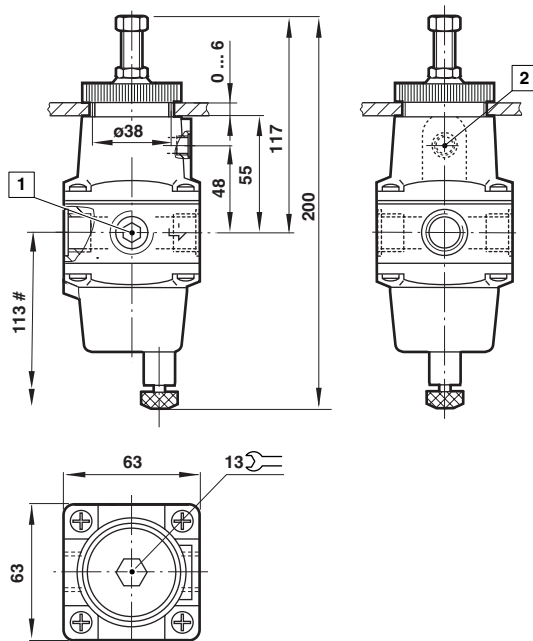
## Dimensions

### Manual drain



# Minimum clearance required to remove bowl

- 1 1/4 PTF Gauge port
- 2 1/8 PTF Exhaust port

### Auto drain

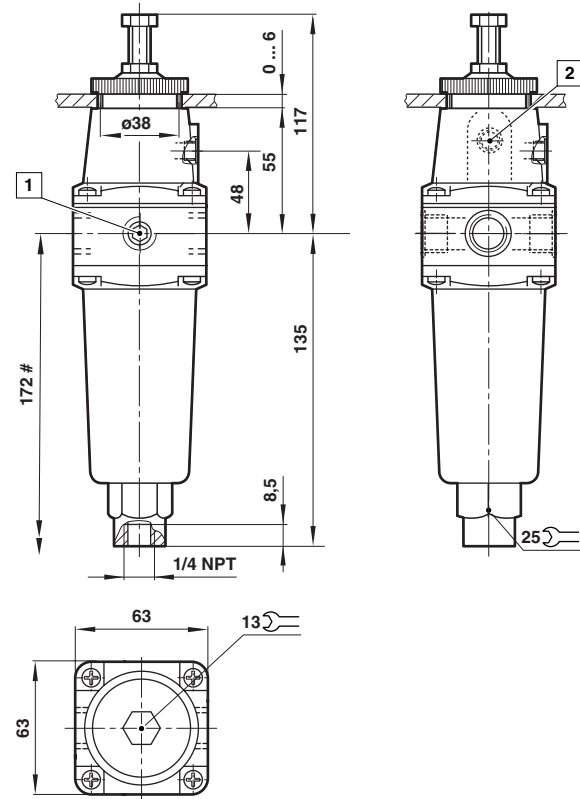

### Neck mounting bracket

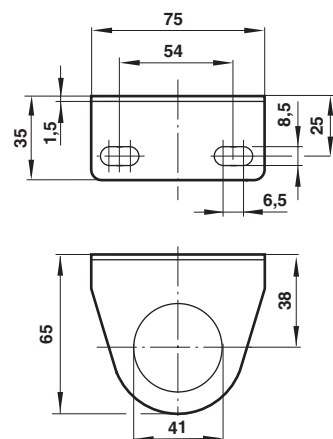

## Warning

These products are intended for use in industrial compressed air systems only. Do not use these products where pressures and temperatures can exceed those listed under »**Technical features**«.

Before using these products with fluids other than those specified, for non-industrial applications, life-support systems, or other applications not within published specifications, consult NORGREN.

Through misuse, age, or malfunction, components used in fluid power systems can fail in various modes.

The system designer is warned to consider the failure modes of all component parts used in pneumatic systems and to provide adequate safeguards to prevent personal injury or damage to equipment in the event of such failure.

System designers must provide a warning to end users in the system instructional manual if protection against a failure mode cannot be adequately provided.

System designers and end users are cautioned to review specific warnings found in instruction sheets packed and shipped with these products.