

陶瓷电阻器 CERAMICS RESISTOR

SQA 陶瓷电阻器 (Wirewound type ceramic core)

MQA 陶瓷电阻器 (Metal oxide film type)

GQA 陶瓷电阻器 (Wirewound type, glass core)

NQA 陶瓷电阻器 (Non-inductance type)



本体颜色: Body Color

标准品: Standard (White 白色)

标示: Marking

文字: Alphanumeric (3W~10W)

(根据客户要求提供相应标识)

(According to the customer request to provide corresponding identification)

结构图 Construction

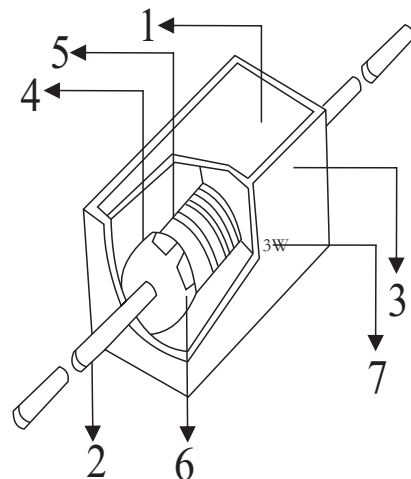
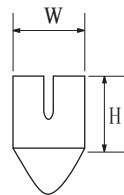
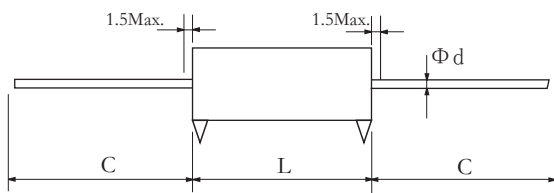

1	2	3	4	5	6	7
二氧化硅填充料	镀锡铜线	陶瓷壳	玻纤棒或陶瓷棒	线绕或氧化膜层	镀锡铁帽	标示
SiO ₂ materials	Tinned copper lead wire	Ceramic shell	Glass core or ceramic core	Wire-wound or metal oxide film	Tinned iron cap	Making

特性 Feature

- I 完全不可燃和高度绝缘性的安全设计
Compact type with safety design of non-flammability and insulation
- II 长期稳定性优良
Stable long life
- III 可提供低电感设计产品
Low inductance is available
- IV 符合欧盟RoHS要求
Products meet EU-RoHS

参考规格 Reference Standards

JIS C 5201-1

陶瓷电阻器 CERAMICS RESISTOR

功率、阻值范围与耐电压 Power And Resistance etc

额定功率 Rated Power(W)	阻值范围 Resistance Range(Ω)		最高使用电压 MaxWorking Voltage	最高负荷电压 MaxOverload Voltage	耐电压Dielectric Withstanding Voltage	温度系数 T.C.R
	皮膜型 Metal oxide film type	绕线型 Wire wound type				
3	100~39K	0.01~3K	350V	1000V	1000V	皮膜型Metal oxide film MQA $\pm 350\text{PPM}/^\circ\text{C}$ 绕线型Wirewound SQA GQA NQA $\pm 100\text{PPM}/^\circ\text{C}$
5	100~50K	0.01~10K	350V	1000V		
7	100~100K	0.05~20K	500V	1500V		
10	100~100K	0.1~20K	750V	1500V		

外形尺寸 Dimensions

规格 Type	功率 Power	尺寸Dimensions(mm)					
		L ± 1.5	W ± 1	H ± 1.5	H ₁ ± 0.5	C ± 3	d ± 0.05
SQA MQA GQA NQA	3W	22.0	8.0	10.0	2.0	33.0	0.70
	5W	22.0	10.0	12.0	3.0	33.0	0.70
	5WF	25.0	6.0	7.0	1.5	33.0	0.70
	7W	35.0	10.0	12.0	3.0	33.0	0.70
	10W	48.0	10.0	12.0	3.0	33.0	0.70

额定温度下降曲线图 Derating Curve

例 Example

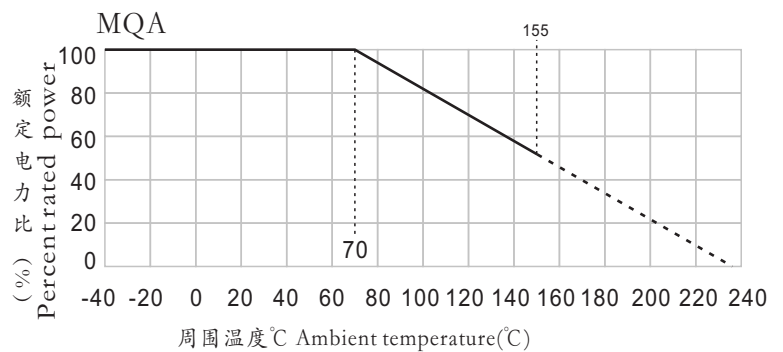
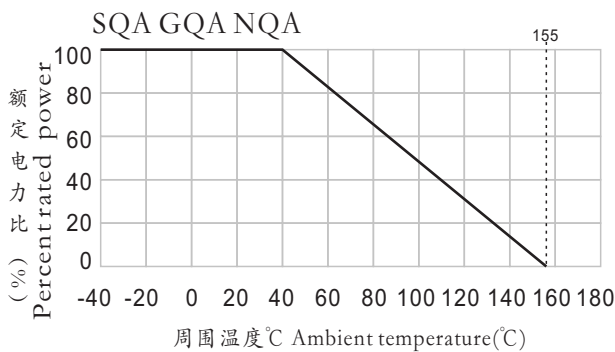

表面温升曲线 Temperature rising curve

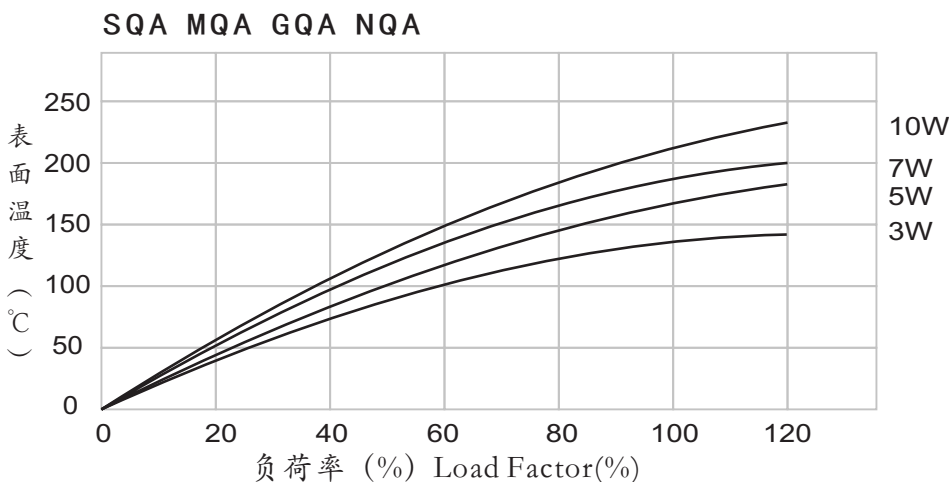

陶瓷电阻器 CERAMICS RESISTOR

性能 Performance

试验项目 Test Items	规格值 Performance Requirements	试验方法 Test Methods(JIS C 5201-1)
电阻值 Resistance	规定的误差值内 Within specified tolerance	测量点从端盖10mm Measuring points are 10mm from the end cap
温度系数 T.C.R.	规定值内 Within specified T.C.R	室温+100℃ Room temperature+100℃
短时间过负荷 Short time overload	±(1%+0.05Ω)	10倍额定功率, 5秒 10 times the rated power for 5 seconds
负荷寿命 Load life	±(5%+0.1Ω)	Rated voltage at 70℃ for 1,000 hours 1.5hr ON/0.5hr OFF Cycles
耐湿负荷寿命 Load life in humidity	±(5%+0.1Ω)	额定电压40℃, 95% RH, 1000小时 Rated voltage at 40℃, 95%RH for 1,000 hours
温度循环 Temperature cycle	±(1%+0.05Ω)	5 cycles for -25℃ (30min); room temp.(30min) ~+85℃ (30min) room temp.(30min)
焊锡耐热 Resistance to soldering heat	±(1%+0.05Ω)	260℃±5℃ for 10 seconds(焊锡槽) 350℃±10℃ for 3.5 seconds(手焊锡)
绝缘电阻 Insulation resistance	> 100MΩ	500V绝缘测试1分钟 500V insulation test 1min.

料号编号 Ordering Information

例 example

型号Type	额定功率 Rated Power	误差值 Tolerance	电阻值 (Ω) Resistance	特殊码 Serial code
SQA MQA GQA	01 02 07 10 25 100	J F G	R100 1R00 10R0 1000	A
绕线型Wirewound type 陶瓷型Ceramic core 氧化皮膜型 Metal oxide film type 绕线型Wirewound type 玻纤型Glass core	01:1W 02:2W 07:7W 10:10W 25:25W 100:100W	J ± 5% F ± 1% G ± 2%	R100=0.1 1R00=1 10R0=10 1000=100	

注意事项：我们还提供如下性能的产品设计，以满足你的需要，
针对SQA、MQA、GQA产品
I 提供超小型尺寸产品设计和生产
II 提供无电感产品设计和制作
III 提供抗脉冲高压产品的设计和生
IV 提供高稳定性和可靠性的军用品与工业品的产品设计和生产
如需更多支持，请联系我们的工程师kh@khxcom.com

To meet your request :

We also provide products for below functions, for SQA、MQA、GQA etc.

- I Mini size design
- II Non-inductive products design
- III Anti-pulse high voltage design
- IV Design resistor for High stability and reliable military supplies and industrial products .

More details please contact with our engineer. kh@khxcom.com