

### FEATURES

- Process Technology : 0.18 $\mu$ m Full CMOS
- Organization : 128K x 8 bit
- Power Supply Voltage : 2.7V ~ 3.6V
- Low Data Retention Voltage : 1.5V (Min)
- Three state output and TTL Compatible
- Package Type
  - 32-sTSOP1, 32-TSOP1, 32-SOP

### GENERAL DESCRIPTION

The EM610FV8 families are fabricated by EMLSI's advanced full CMOS process technology. The families support industrial temperature range and Chip Scale Package for user flexibility of system design. The families also supports low data retention voltage for battery back-up operation with low data retention current.

### PRODUCT FAMILY

Product Family	Operating Temperature	Vcc Range	Speed	Power Dissipation		PKG Type
				Standby ( $I_{SB1}$ , Typ.)	Operating ( $I_{CC1}$ -Max.)	
EM610FV8	Industrial (-40 ~ 85°C)	2.7 ~ 3.6 V	45/55/70 ns	0.3 $\mu$ A <sup>2</sup> )	3 mA	KGD
EM610FV8S - xx <sup>1</sup> )LF						32-sTSOP1
EM610FV8T - xx <sup>1</sup> )LF						32-TSOP1
EM610FV8V - xx <sup>1</sup> )LF						32-SOP

1. "xx" represents speed.

2. Typical values are measured at  $V_{CC}=3.3V$ ,  $T_A=25^\circ C$  and not 100% tested.

### FUNCTIONAL BLOCK DIAGRAM

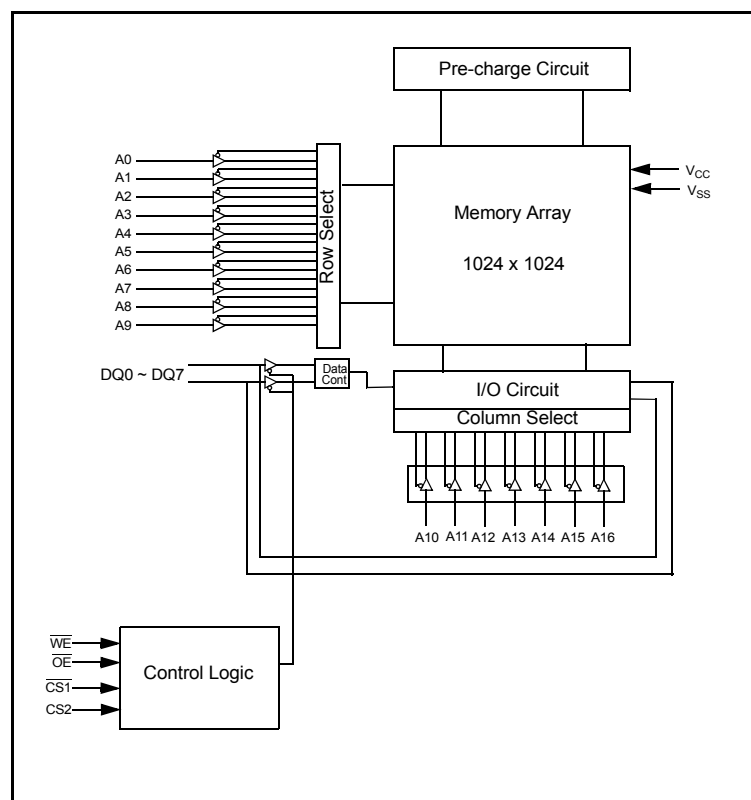

## PIN CONFIGURATIONS

32 - sTSOP1, 32 - TSOP1 : Top view

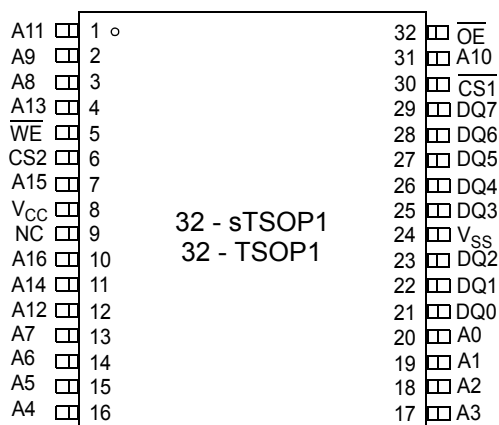

32 - SOP : Top view

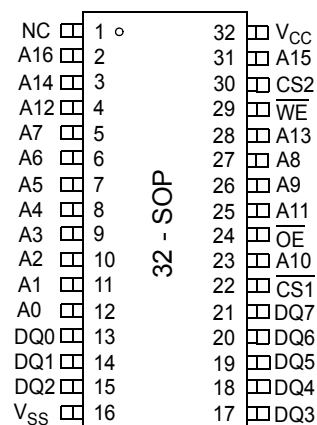

## PIN DESCRIPTION

Name	Function	Name	Function
$\overline{CS}_1, \overline{CS}_2$	Chip Select input	$V_{CC}$	Power Supply
$\overline{OE}$	Output Enable input	$V_{SS}$	Ground
$\overline{WE}$	Write Enable input		
A0~A16	Address inputs		
DQ0~DQ7	Data inputs/outputs		

**ABSOLUTE MAXIMUM RATINGS<sup>1)</sup>**

Parameter	Symbol	Ratings	Unit
Voltage on Any Pin Relative to V <sub>SS</sub>	V <sub>IN</sub> , V <sub>OUT</sub>	-0.2 to 4.0	V
Voltage on V <sub>CC</sub> supply relative to V <sub>SS</sub>	V <sub>CC</sub>	-0.2 to 4.0	V
Power Dissipation	P <sub>D</sub>	1.0	W
Operating Temperature	T <sub>A</sub>	-40 to 85	°C

1. Stresses greater than those listed under "Absolute Maximum Ratings" may cause permanent damage to the device. Functional operation should be restricted to recommended operating condition. Exposure to absolute maximum rating conditions for extended periods may affect reliability.

**FUNCTIONAL DESCRIPTION**

$\overline{\text{CS1}}$	$\text{CS2}$	$\overline{\text{OE}}$	$\overline{\text{WE}}$	DQ0~7	Mode	Power
H	X	X	X	High-Z	Deselected	Stand by
X	L	X	X	High-Z	Deselected	Active
L	H	H	H	High-Z	Output Disabled	Active
L	H	L	H	Data Out	Read	Active
L	H	X	L	Data In	Write	Active

NOTE : X means don't care. (Must be low or high state)

### RECOMMENDED DC OPERATING CONDITIONS <sup>1)</sup>

Parameter	Symbol	Min	Typ	Max	Unit
Supply voltage	$V_{CC}$	2.7	3.3	3.6	V
Ground	$V_{SS}$	0	0	0	V
Input high voltage	$V_{IH}$	2.2	-	$V_{CC} + 0.2^{2)}$	V
Input low voltage	$V_{IL}$	$-0.2^{3)}$	-	0.6	V

1.  $T_A = -40$  to  $85^\circ\text{C}$ , otherwise specified
2. Overshoot:  $V_{CC} + 2.0$  V in case of pulse width  $\leq 20$ ns
3. Undershoot:  $-2.0$  V in case of pulse width  $\leq 20$ ns
4. Overshoot and undershoot are sampled, not 100% tested.

### CAPACITANCE <sup>1)</sup> ( $f = 1\text{MHz}$ , $T_A = 25^\circ\text{C}$ )

Item	Symbol	Test Condition	Min	Max	Unit
Input capacitance	$C_{IN}$	$V_{IN} = 0\text{V}$	-	8	pF
Input/Output capacitance	$C_{IO}$	$V_{IO} = 0\text{V}$	-	10	pF

1. Capacitance is sampled, not 100% tested.

### DC AND OPERATING CHARACTERISTICS

Parameter	Symbol	Test Conditions	Min	Typ	Max	Unit			
Input leakage current	$I_{LI}$	$V_{IN} = V_{SS}$ to $V_{CC}$	-1	-	1	$\mu\text{A}$			
Output leakage current	$I_{LO}$	$\overline{CS}_1 = V_{IH}$ or $CS_2 = V_{IL}$ or $\overline{OE} = V_{IH}$ or $\overline{WE} = V_{IL}$ or $V_{IO} = V_{SS}$ to $V_{CC}$	-1	-	1	$\mu\text{A}$			
Operating power supply	$I_{CC}$	$I_{IO} = 0\text{mA}$ , $\overline{CS}_1 = V_{IL}$ , $CS_2 = \overline{WE} = V_{IH}$ , $V_{IN} = V_{IH}$ or $V_{IL}$	-	-	3	mA			
Average operating current	$I_{CC1}$	Cycle time = $1\mu\text{s}$ , 100% duty, $I_{IO} = 0\text{mA}$ , $\overline{CS}_1 \leq 0.2\text{V}$ , $CS_2 \geq V_{CC} - 0.2\text{V}$ , $V_{IN} \leq 0.2\text{V}$ or $V_{IN} \geq V_{CC} - 0.2\text{V}$	-	-	3	mA			
			$I_{CC2}$	Cycle time = Min, $I_{IO} = 0\text{mA}$ , 100% duty, $\overline{CS}_1 = V_{IL}$ , $CS_2 = V_{IH}$ , $V_{IN} = V_{IL}$ or $V_{IH}$	45ns	-	-	30	mA
					55ns	-	-	25	
			70ns	-	-	20			
Output low voltage	$V_{OL}$	$I_{OL} = 2.1\text{mA}$	-	-	0.4	V			
Output high voltage	$V_{OH}$	$I_{OH} = -1.0\text{mA}$	2.4	-	-	V			
Standby Current (TTL)	$I_{SB}$	$\overline{CS}_1 = V_{IH}$ , $CS_2 = V_{IL}$ , Other inputs = $V_{IH}$ or $V_{IL}$	-	-	0.3	mA			
Standby Current (CMOS)	$I_{SB1}$	$\overline{CS}_1 \geq V_{CC} - 0.2\text{V}$ , $CS_2 \geq V_{CC} - 0.2\text{V}$ ( $\overline{CS}_1$ controlled) or $0\text{V} \leq CS_2 \leq 0.2\text{V}$ ( $CS_2$ controlled), Other inputs = $0 \sim V_{CC}$ (Typ. condition : $V_{CC} = 3.3\text{V}$ @ $25^\circ\text{C}$ ) (Max. condition : $V_{CC} = 3.6\text{V}$ @ $85^\circ\text{C}$ )	LL LF	-	$0.3^{1)}$	1.5	$\mu\text{A}$		

1. Typical values are measured at  $V_{CC} = 3.3\text{V}$ ,  $T_A = 25^\circ\text{C}$  and not 100% tested.

### AC OPERATING CONDITIONS

**Test Conditions** (Test Load and Test Input/Output Reference)

Input Pulse Level : 0.4 to 2.2V

Input Rise and Fall Time : 5ns

Input and Output reference Voltage : 1.5V

Output Load (See right) :  $CL^{(1)} = 100\text{pF} + 1 \text{ TTL (70ns)}$

$CL^{(1)} = 30\text{pF} + 1 \text{ TTL (45ns/55ns)}$

1. Including scope and Jig capacitance

2.  $R_1=3070\Omega$ ,  $R_2=3150\Omega$

3.  $V_{TM} = 2.8\text{V}$

4.  $CL = 5\text{pF} + 1 \text{ TTL (measurement with tLZ, tOLZ, tHZ, tOHZ, tWHZ)}$

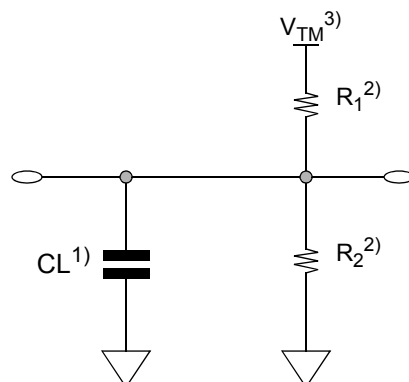

**READ CYCLE** ( $V_{CC} = 2.7$  to  $3.6\text{V}$ ,  $Gnd = 0\text{V}$ ,  $T_A = -40^\circ\text{C}$  to  $+85^\circ\text{C}$ )

Parameter	Symbol	45ns		55ns		70ns		Unit
		Min	Max	Min	Max	Min	Max	
Read cycle time	$t_{RC}$	45	-	55	-	70	-	ns
Address access time	$t_{AA}$	-	45	-	55	-	70	ns
Chip select to output	$t_{CO1}, t_{CO2}$	-	45	-	55	-	70	ns
Output enable to valid output	$t_{OE}$	-	25	-	25	-	35	ns
Chip select to low-Z output	$t_{LZ1}, t_{LZ2}$	10	-	10	-	10	-	ns
Output enable to low-Z output	$t_{OLZ}$	5	-	5	-	5	-	ns
Chip disable to high-Z output	$t_{HZ1}, t_{HZ2}$	0	20	0	20	0	25	ns
Output disable to high-Z output	$t_{OHZ}$	0	15	0	20	0	25	ns
Output hold from address change	$t_{OH}$	10	-	10	-	10	-	ns

**WRITE CYCLE** ( $V_{CC} = 2.7$  to  $3.6\text{V}$ ,  $Gnd = 0\text{V}$ ,  $T_A = -40^\circ\text{C}$  to  $+85^\circ\text{C}$ )

Parameter	Symbol	45ns		55ns		70ns		Unit
		Min	Max	Min	Max	Min	Max	
Write cycle time	$t_{WC}$	45	-	55	-	70	-	ns
Chip select to end of write	$t_{CW1}, t_{CW2}$	35	-	40	-	60	-	ns
Address setup time	$t_{AS}$	0	-	0	-	0	-	ns
Address valid to end of write	$t_{AW}$	35	-	40	-	60	-	ns
Write pulse width	$t_{WP}$	30	-	30	-	35	-	ns
Write recovery time	$t_{WR}$	0	-	0	-	0	-	ns
Write to output high-Z	$t_{WHZ}$	0	15	0	20	0	25	ns
Data to write time overlap	$t_{DW}$	25	-	25	-	30	-	ns
Data hold from write time	$t_{DH}$	0	-	0	-	0	-	ns
End write to output low-Z	$t_{OW}$	5	-	5	-	5	-	ns

**TIMING DIAGRAMS**

**TIMING WAVEFORM OF READ CYCLE(1)** (Address Controlled,  $\overline{CS}=\overline{OE}=V_{IL}$ ,  $CS2=\overline{WE}=V_{IH}$ )

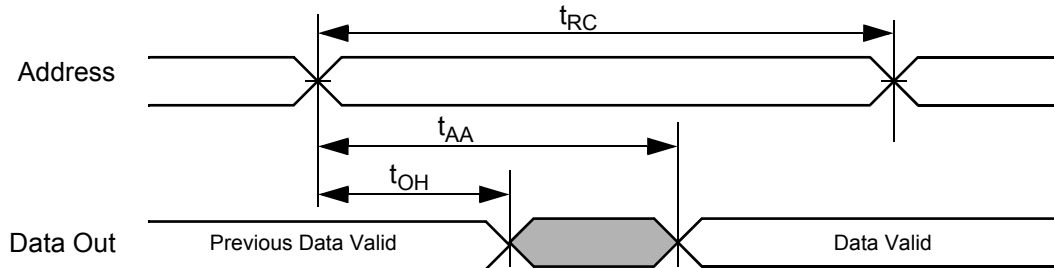

**TIMING WAVEFORM OF READ CYCLE(2)** ( $\overline{WE} = V_{IH}$ )

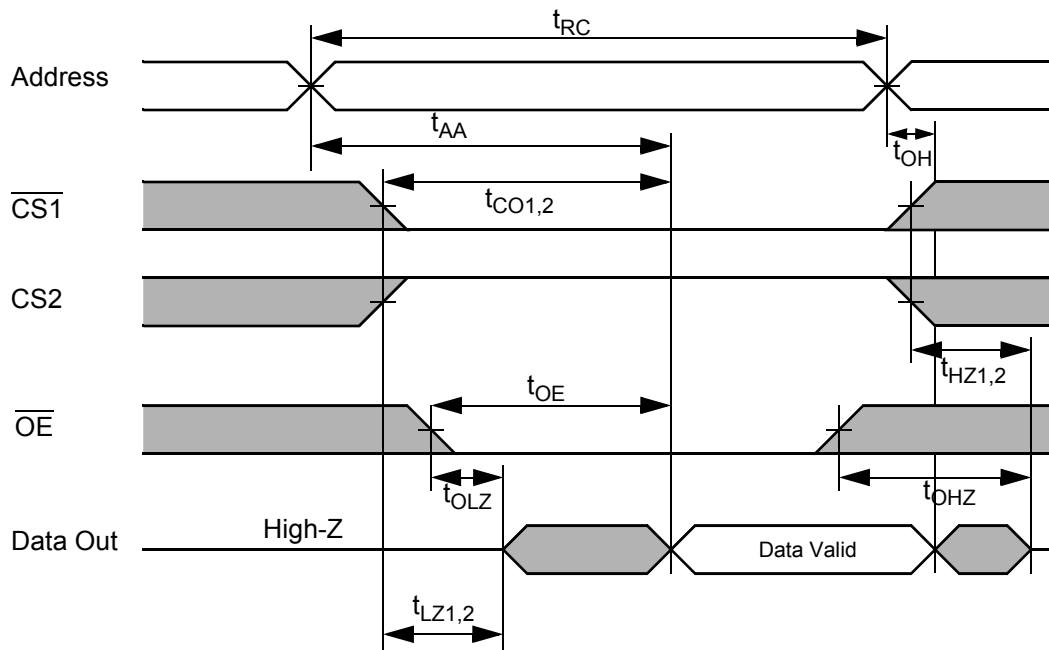

**NOTES (READ CYCLE)**

1.  $t_{HZ1,2}$  and  $t_{OHZ}$  are defined as the outputs achieve the open circuit conditions and are not referenced to output voltage levels.
2. At any given temperature and voltage condition,  $t_{HZ1,2}(\text{Max.})$  is less than  $t_{LZ1,2}(\text{Min.})$  both for a given device and from device to device interconnection.

**TIMING WAVEFORM OF WRITE CYCLE(1) ( $\overline{WE}$  Controlled)**

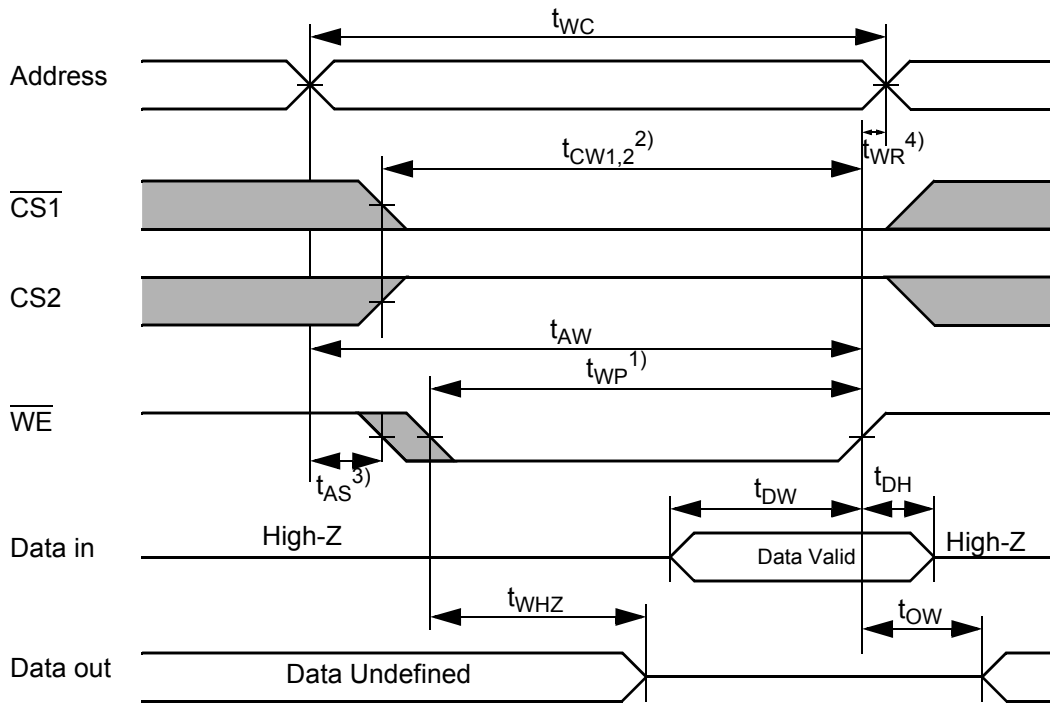

**TIMING WAVEFORM OF WRITE CYCLE(2) ( $\overline{CS1}$  Controlled)**

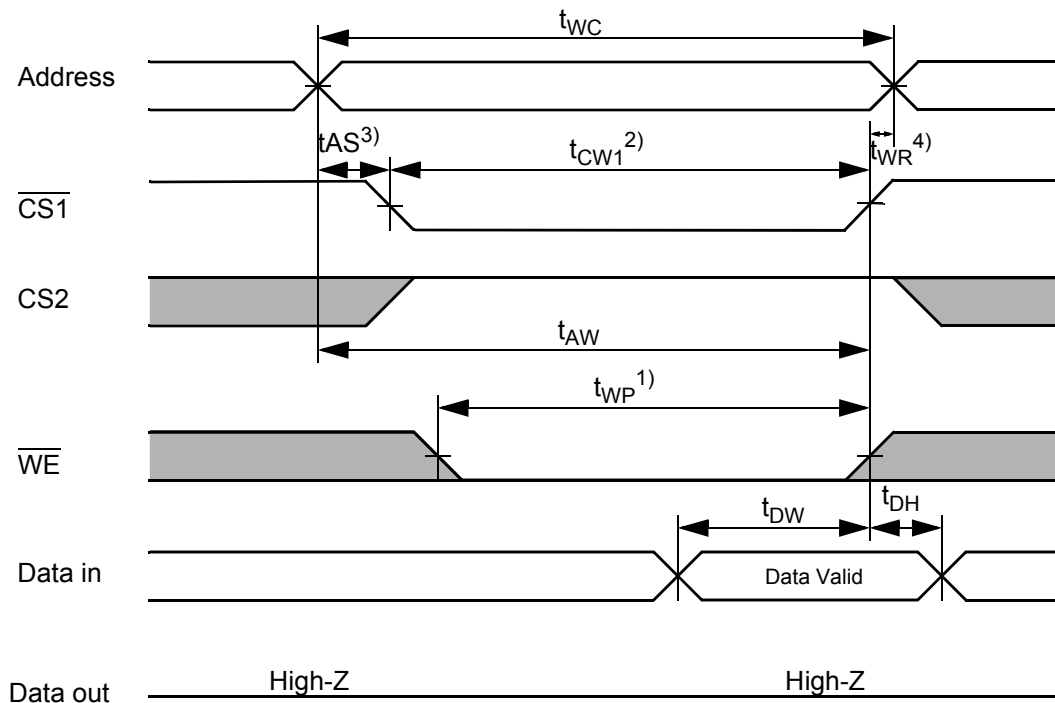

**TIMING WAVEFORM OF WRITE CYCLE(3) (CS2 Controlled)**

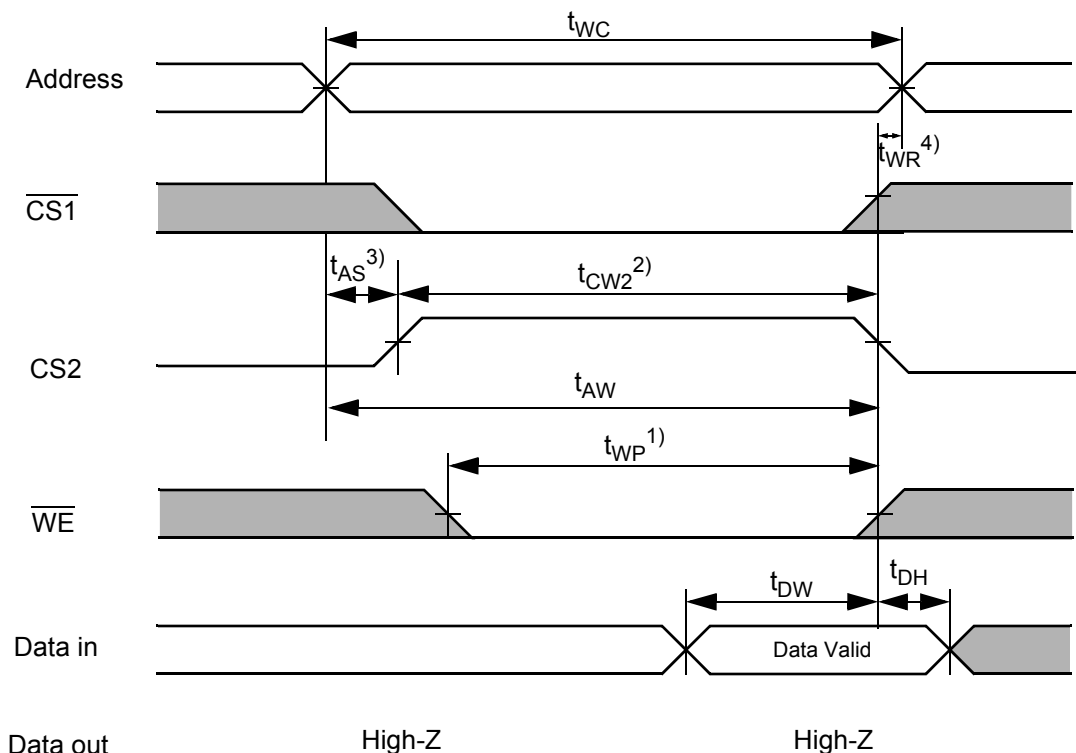

**NOTES (WRITE CYCLE)**

1. A write occurs during the overlap ( $t_{WP}^{(1)}$ ) of low  $\overline{CS1}$ , a high CS2 and low  $\overline{WE}$ . A write begins at the latest transition among  $\overline{CS1}$  goes low, CS2 goes high and  $\overline{WE}$  goes low. A write ends at the earliest transition when  $\overline{CS1}$  goes high, CS2 goes high and  $\overline{WE}$  goes high. The  $t_{WP}^{(1)}$  is measured from the beginning of write to the end of write.
2.  $t_{CW}^{(2)}$  is measured from the  $\overline{CS1}$  going low or CS2 going high to end of write.
3.  $t_{AS}^{(3)}$  is measured from the address valid to the beginning of write.
4.  $t_{WR}^{(4)}$  is measured from the end of write to the address change.  $t_{WR}^{(4)}$  applied in case a write ends as  $\overline{CS1}$  or  $\overline{WE}$  going high.



**DATA RETENTION CHARACTERISTICS**

Parameter	Symbol	Test Condition	Min	Typ <sup>2)</sup>	Max	Unit
V <sub>CC</sub> for Data Retention	V <sub>DR</sub>	I <sub>SB1</sub> Test Condition (Chip Disabled) <sup>1)</sup>	1.5	-	3.6	V
Data Retention Current	I <sub>DR</sub>	V <sub>CC</sub> =1.5V, I <sub>SB1</sub> Test Condition (Chip Disabled) <sup>1)</sup>	-	0.25	-	μA
Chip Deselect to Data Retention Time	t <sub>SDR</sub>	See data retention wave form	0	-	-	ns
Operation Recovery Time	t <sub>RDR</sub>		t <sub>RC</sub>	-	-	

**NOTES**

1. See the I<sub>SB1</sub> measurement condition of datasheet page 5.
2. Typical values are measured at T<sub>A</sub>=25°C and not 100% tested.

**DATA RETENTION WAVE FORM**

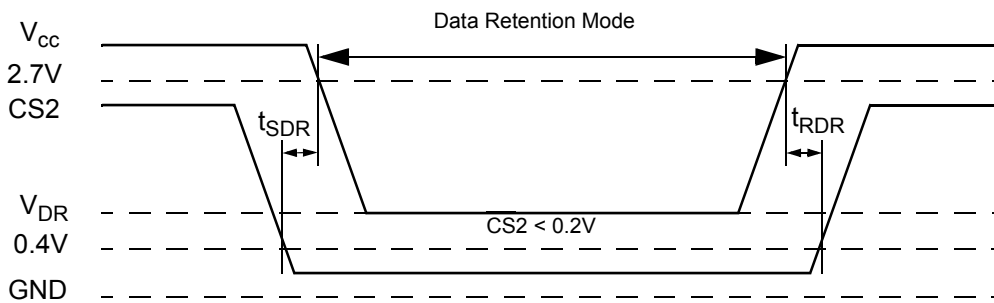
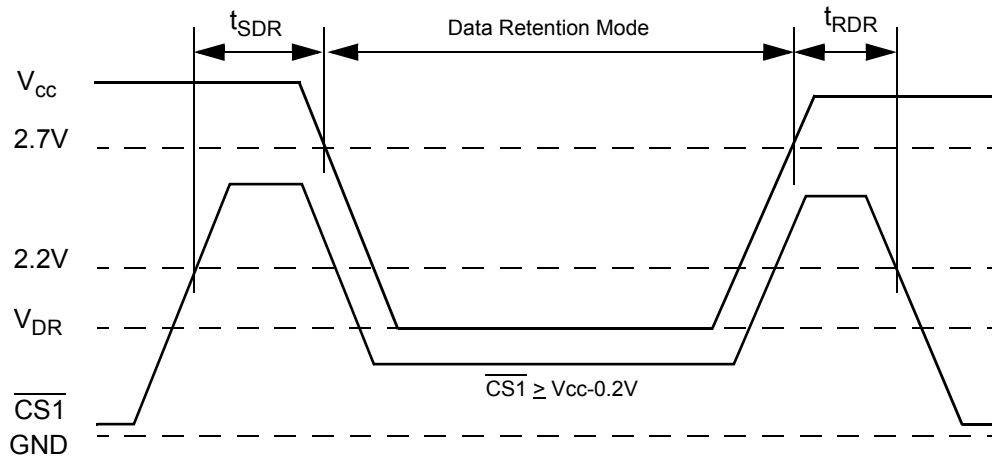

**PACKAGE DIMENSIONS**

32Pin - sTSOP Type1

Unit : millimeters/Inches

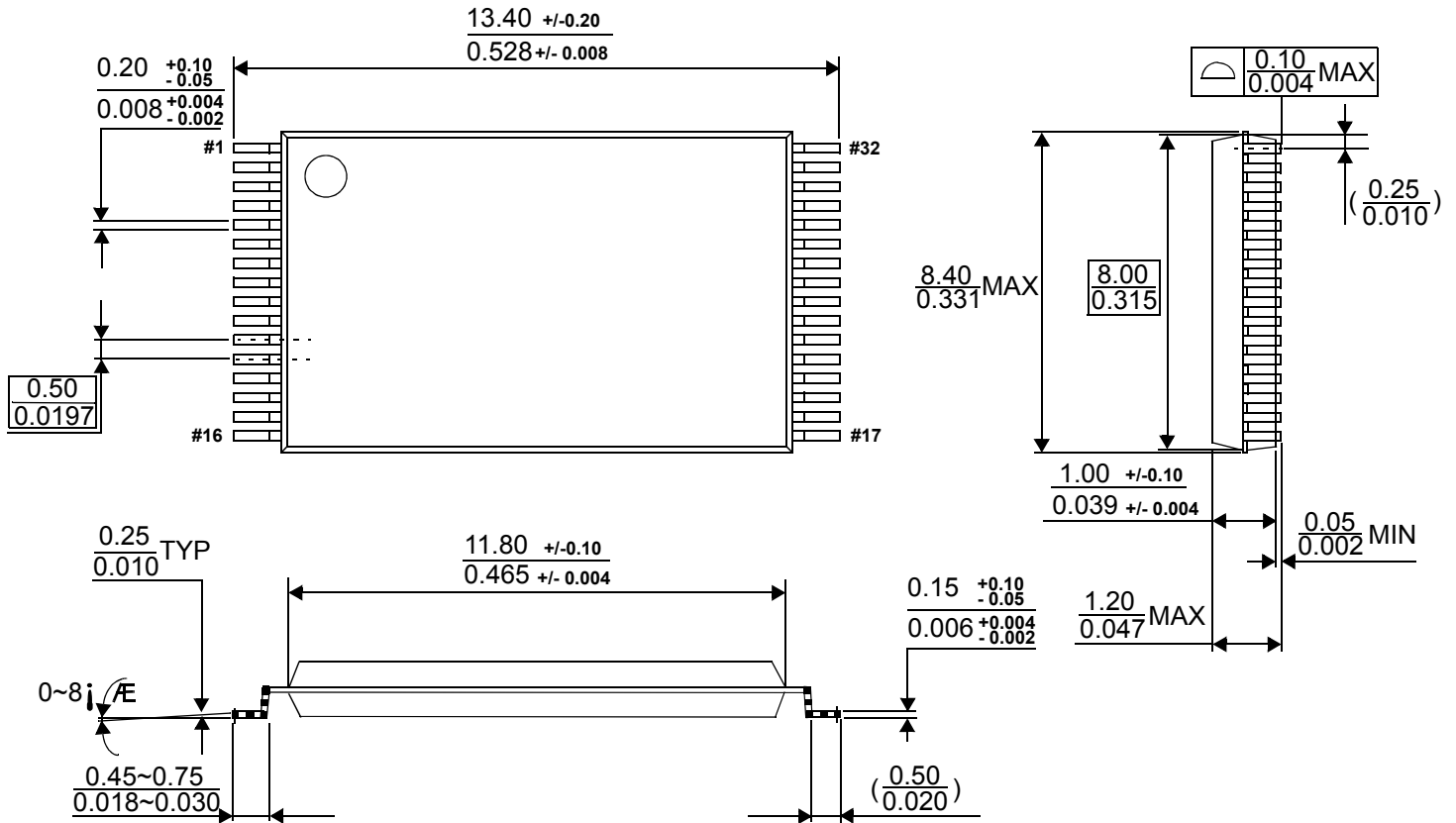

**PACKAGE DIMENSIONS**

32Pin - TSOP Type1

Unit : millimeters/Inches

32 PIN THIN SMALL OUTLINE PACKAGE TYPE I (0820F)

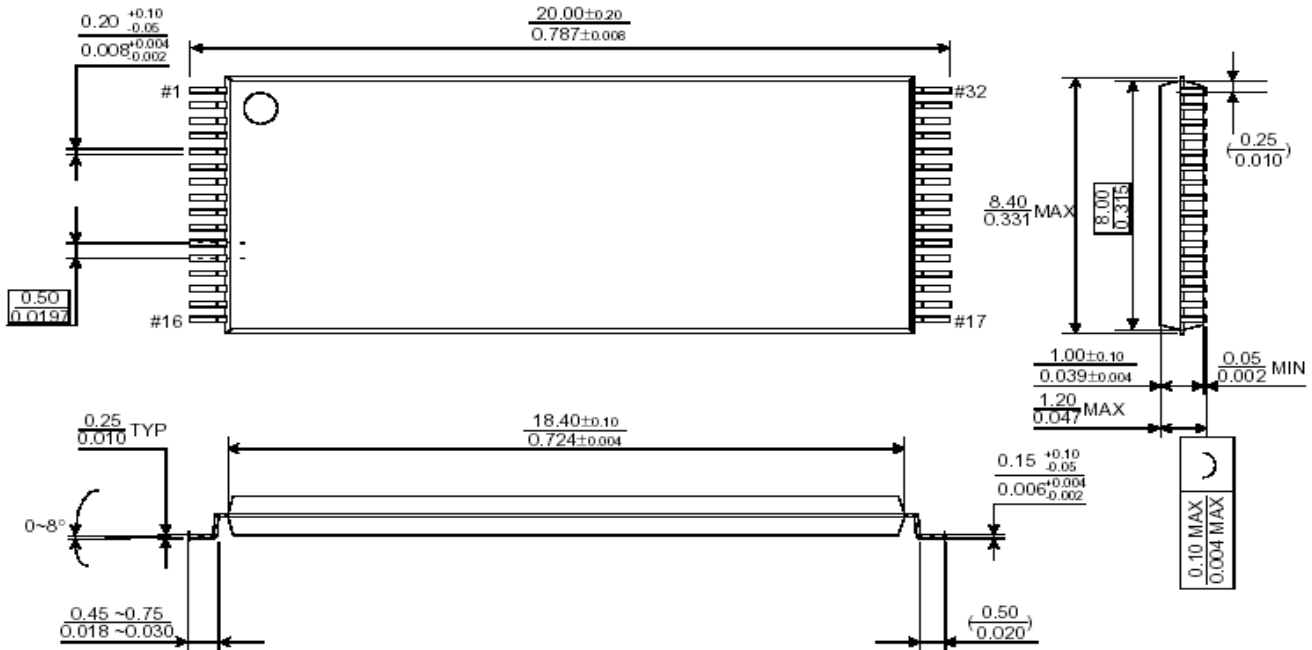

**PACKAGE DIMENSIONS**

32Pin - SOP

Unit : millimeters/Inches

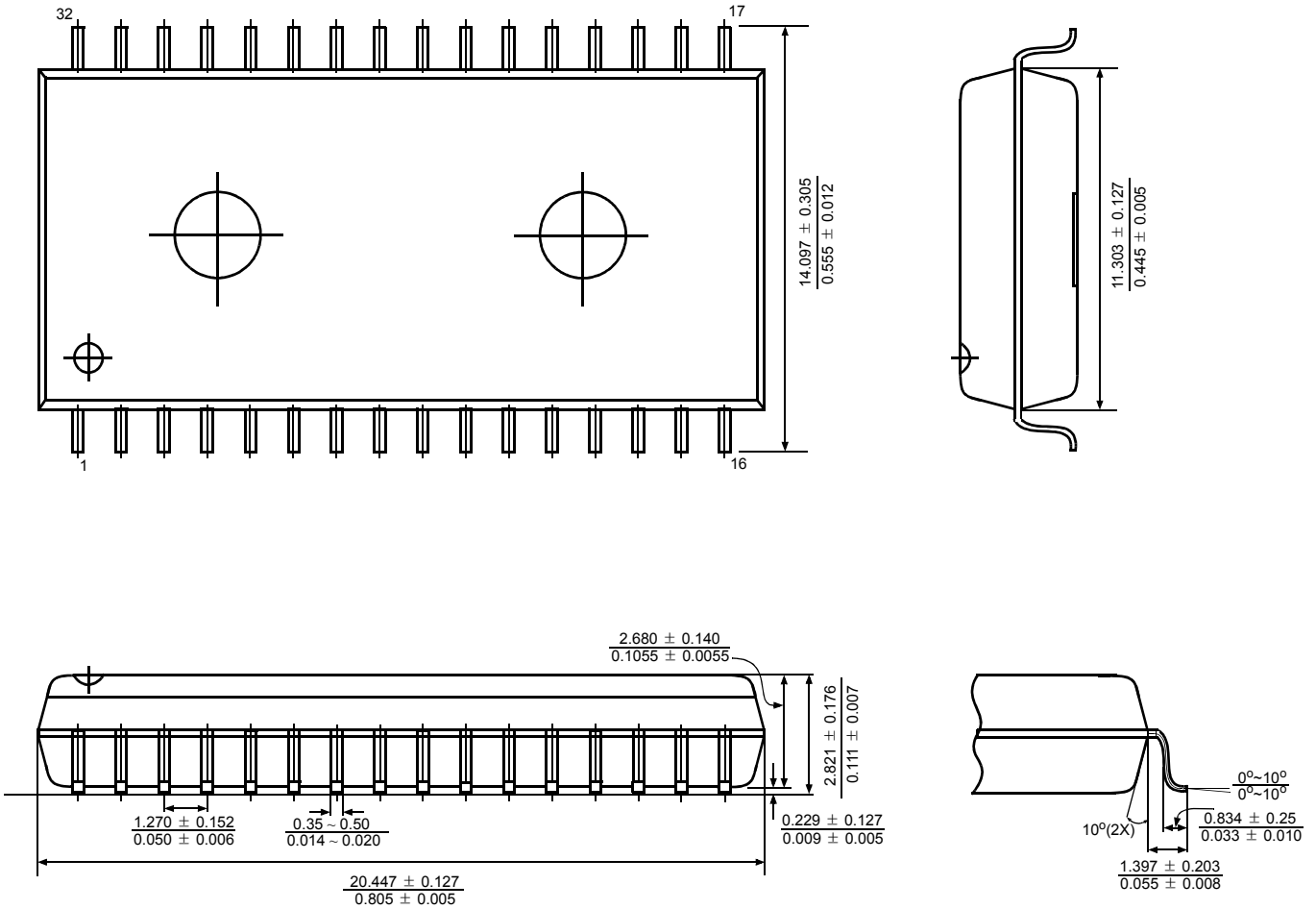

**MEMORY FUNCTION GUIDE**

EMXXXXXXXXXXXXX - XXXX

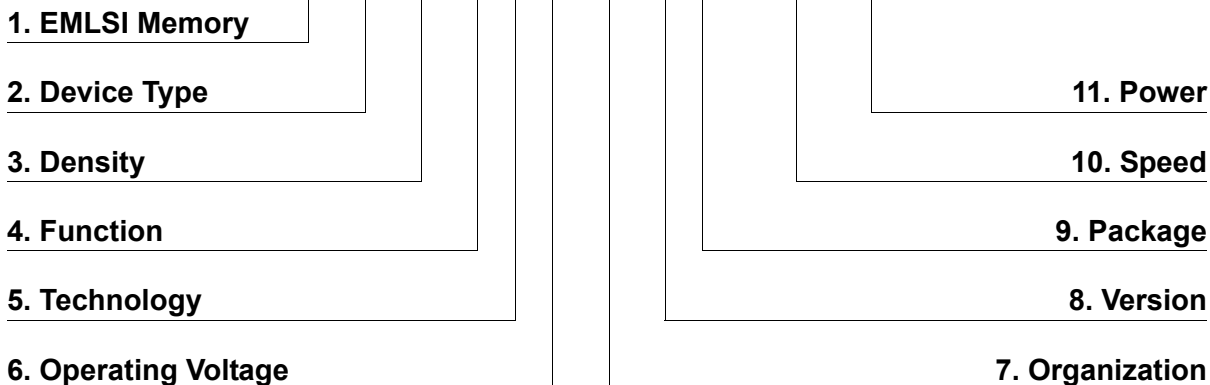

**1. Memory Component**

**2. Device Type**

- 6 ----- Low Power SRAM
- 7 ----- STRAM
- C ----- CellularRAM

**3. Density**

- 1 ----- 1M
- 2 ----- 2M
- 4 ----- 4M
- 8 ----- 8M
- 16 ----- 16M
- 32 ----- 32M
- 64 ----- 64M
- 28 ----- 128M

**4. Option**

- 0 ----- Dual CS
- 1 ----- Single CS

**5. Technology**

- F ----- Full CMOS

**6. Operating Voltage**

- T ----- 5.0V
- V ----- 3.3V
- U ----- 3.0V
- S ----- 2.5V
- R ----- 2.0V
- P ----- 1.8V

**7. Organization**

- 8 ----- X8 bit
- 16 ----- X16 bit
- 32 ----- X32 bit

**8. Version**

- Blank----- Mother die
- A ----- 2 nd generation
- B ----- 3 rd generation
- C ----- 4 th generation
- D ----- 5 th generation
- E ----- 6 th generation
- F ----- 7 th generation
- G ----- 8 th generation

**9. Package**

- Blank----- KGD, FBGA
- S ----- 32 sTSOP1
- T ----- 32 TSOP1
- U ----- 44 TSOP2
- V ----- 32 SOP

**10. Speed**

- 45 ----- 45ns
- 55 ----- 55ns
- 60 ----- 60ns
- 70 ----- 70ns
- 85 ----- 85ns
- 90 ----- 90ns
- 10 ----- 100ns
- 12 ----- 120ns

**11. Power**

- LL ----- Low Low Power
- LF ----- Low Low Power(Pb-free & Green)
- L ----- Low Power
- S ----- Standard Power