

18Mb Sync. Pipelined Burst SRAM Specification

INFORMATION IN THIS DOCUMENT IS PROVIDED IN RELATION TO NETSOL PRODUCTS, AND IS SUBJECT TO CHANGE WITHOUT NOTICE.

NOTHING IN THIS DOCUMENT SHALL BE CONSTRUED AS GRANTING ANY LICENSE, EXPRESS OR IMPLIED, BY ESTOPPEL OR OTHERWISE,

TO ANY INTELLECTUAL PROPERTY RIGHTS IN NETSOL PRODUCTS OR TECHNOLOGY. ALL INFORMATION IN THIS DOCUMENT IS PROVIDED

ON AS "AS IS" BASIS WITHOUT GUARANTEE OR WARRANTY OF ANY KIND.

1. For updates or additional information about Netsol products, contact your nearest Netsol office.
2. Netsol products are not intended for use in life support, critical care, medical, safety equipment, or similar applications where Product failure could result in loss of life or personal or physical harm, or any military or defense application, or any governmental procurement to which special terms or provisions may apply.

* Netsol reserves the right to change products or specification without notice.

Document Title

512Kx36 & 1Mx18 Bit Synchronous Pipelined Burst SRAM

Revision History

Rev. No.	History	Draft Date	Remark
0.0	Initial Draft	Feb. 2012	Advanced
1.0	Final Spec release Insert ICC spec parameters	Jul. 2012	Final

512Kx36 & 1Mx18 Bit Synchronous Pipelined Burst SRAM

Features

- V_{DD} = 2.5V(2.3V ~ 2.7V) or 3.3V(3.1V ~ 3.5V) Power Supply
- V_{DDQ} = 2.3V~2.7V I/O Power Supply (V_{DD}=2.5V) or 2.3V~3.5V I/O Power Supply (V_{DD}=3.3V)
- Synchronous Operation
- 2 Stage Pipelined operation with 4 Burst
- On-Chip Address Counter
- Self-Timed Write Cycle
- On-Chip Address and Control Registers
- Byte Writable Function
- Global Write Enable Controls a full bus-width write
- Power Down State via ZZ Signal
- L_{B0} Pin allows a choice of either a interleaved burst or a linear burst
- Three Chip Enables for simple depth expansion with No Data Contention only for TQFP ; 2cycle Enable, 1cycle Disable
- Asynchronous Output Enable Control
- ADSP, ADSC, ADV Burst Control Pins
- TTL-Level Three-State Output
- Operating in commercial and industrial temperature range
- 100-TQFP-1420A (Lead free package)

General Description

The S7A163630M and S7A161830M are 18,874,368-bit Synchronous Static Random Access Memory designed for high performance.

It is organized as 512K(1M) words of 36(18) bits and integrates address and control registers, a 2-bit burst address counter and added some new functions for high performance applications; \overline{GW} , \overline{BW} , L_{B0}, ZZ. Write cycles are internally self-timed and synchronous.

Full bus-width write is done by \overline{GW} , and each byte write is performed by the combination of \overline{WEx} and \overline{BW} when \overline{GW} is high. And with $\overline{CS_1}$ high, ADSP is blocked to control signals.

Burst cycle can be initiated with either the address status processor(ADSP) or address status cache controller(ADSC) inputs. Subsequent burst addresses are generated internally in the system's burst sequence and are controlled by the burst address advance(ADV) input.

L_{B0} pin is DC operated and determines burst sequence(linear or interleaved).

ZZ pin controls Power Down State and reduces Stand-by current regardless of CLK.

The S7A163630M and S7A161830M are fabricated using high performance CMOS technology and is available in a 100pin TQFP package. Multiple power and ground pins are utilized to minimize ground bounce.

Key Parameters

Parameter	Symbol	-25	-16	Unit
Cycle Time	tCYC	4.0	6.0	ns
Clock Access Time	tCD	2.6	3.5	ns
Output Enable Access Time	tOE	2.6	3.5	ns
Operating Current	I _{cc}	150	110	mA
Standby Current	I _{SB2}	35	35	mA

16Mb Synchronous Pipelined Burst SRAM Ordering Information

Org.	VDD (V)	Speed (ns)	Access Time (ns)	Part Number	RoHS Avail.
1Mx18	3.3/2.5	4.0	2.6	S7A161830M-PC(I)25	0
	3.3/2.5	6.0	3.5	S7A161830M-PC(I)16	0
512Kx36	3.3/2.5	4.0	2.6	S7A163630M-PC(I)25	0
	3.3/2.5	6.0	3.5	S7A163630M-PC(I)16	0

Note 1. P [Package type] : P - Pb Free
2. C(I) [Operating Temperature] : C-Commercial, I-Industrial

S7A163630M
S7A161830M

512Kx36 & 1Mx18 Sync-Pipelined Burst SRAM

100 TQFP Package Pin Configurations(Top View)

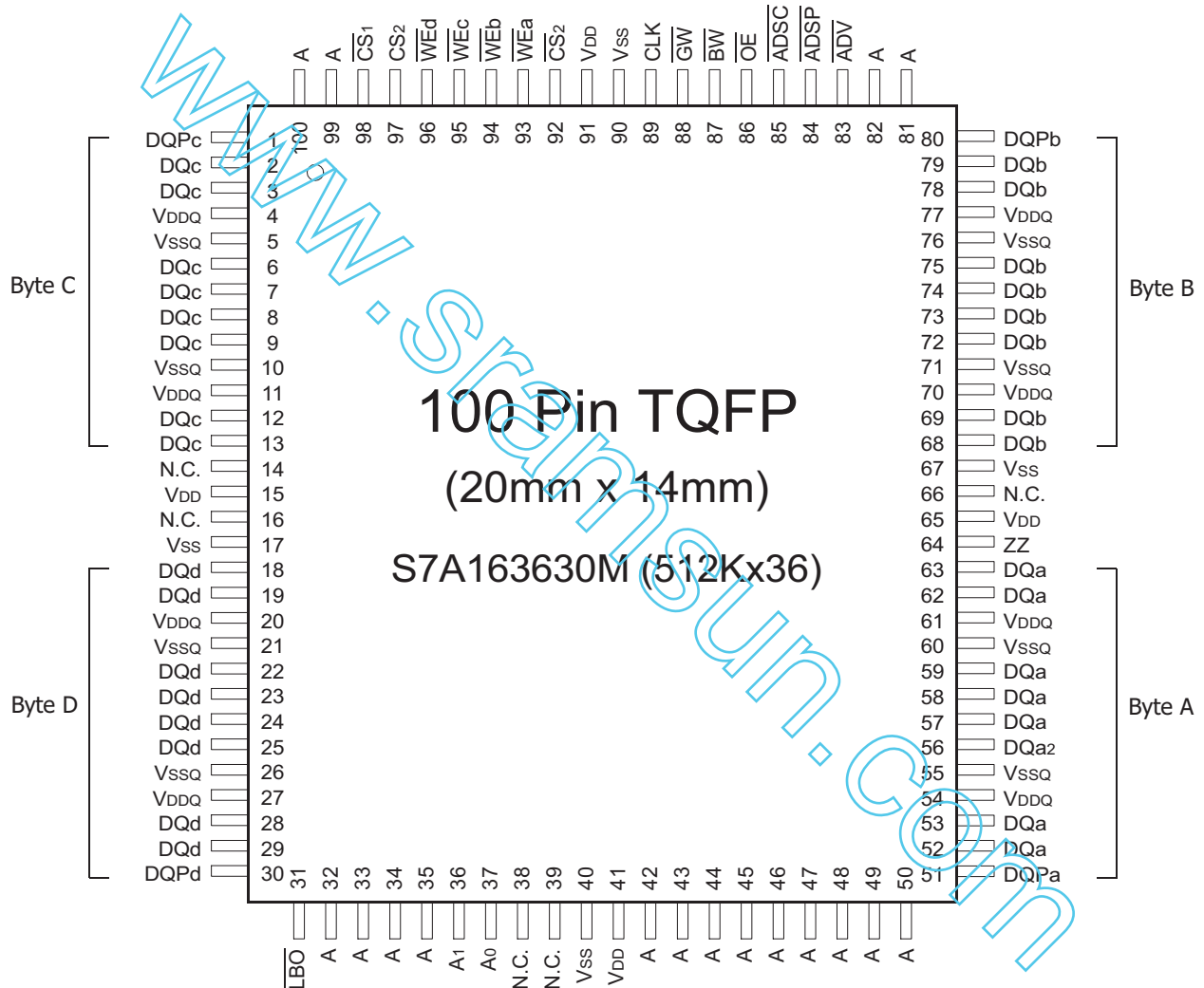

Pin Name

Symbol	Pin Name	TQFP Pin NO.	Symbol	Pin Name	TQFP Pin NO.
A	Address Inputs	32,33,34,35,42,43,44,45,46,47,48,49,50,81,82,99,100	VDD	Power Supply (2.5V~3.3V)	15,41,65,91
A0,A1	Burst Address Inputs	37,36	VSS	Ground	17,40,67,90
ADV	Burst Address Advance	83	N.C.	No Connect	14,16,38,39,66
ADSP	Address Status Processor	84	DQa	Data Inputs/Outputs	52,53,56,57,58,59,62,63,68,69,72,73,74,75,78,79
ADSC	Address Status Controller	85	DQb		2,3,6,7,8,9,12,13
CLK	Clock	89	DQc		18,19,22,23,24,25,28,29
CS1	Chip Select	98	DQd		51,80,1,30
CS2	Chip Select	97	DQPa~Pd		
CS2	Chip Select	92	VDDQ	Output Power Supply (2.5V~3.3V)	4,11,20,27,54,61,70,77
WEx(x=a,b,c,d)	Byte Write Inputs	93,94,95,96	VSSQ	Output Ground	5,10,21,26,55,60,71,76
OE	Output Enable	86			
GW	Global Write Enable	88			
BW	Byte Write Enable	87			
ZZ	Power Down Input	64			
LBO	Burst Mode Control	31			

Note : 1. A0 and A1 are the two least significant bits(LSB) of the address field and set the internal burst counter if burst is desired.

Rev. 1.0 Jul. 2012

Ramsun International Limited
英尚国际有限公司

- 5 -



北京:010-5716 9760 上海:021-6678 7052 深圳:0755-6111 9155 苏州:0512-6631 5215
Http://www.sramsun.com E-mail: sales@sramsun.com

S7A163630M
S7A161830M

512Kx36 & 1Mx18 Sync-Pipelined Burst SRAM

100 TQFP Package Pin Configurations(Top View)

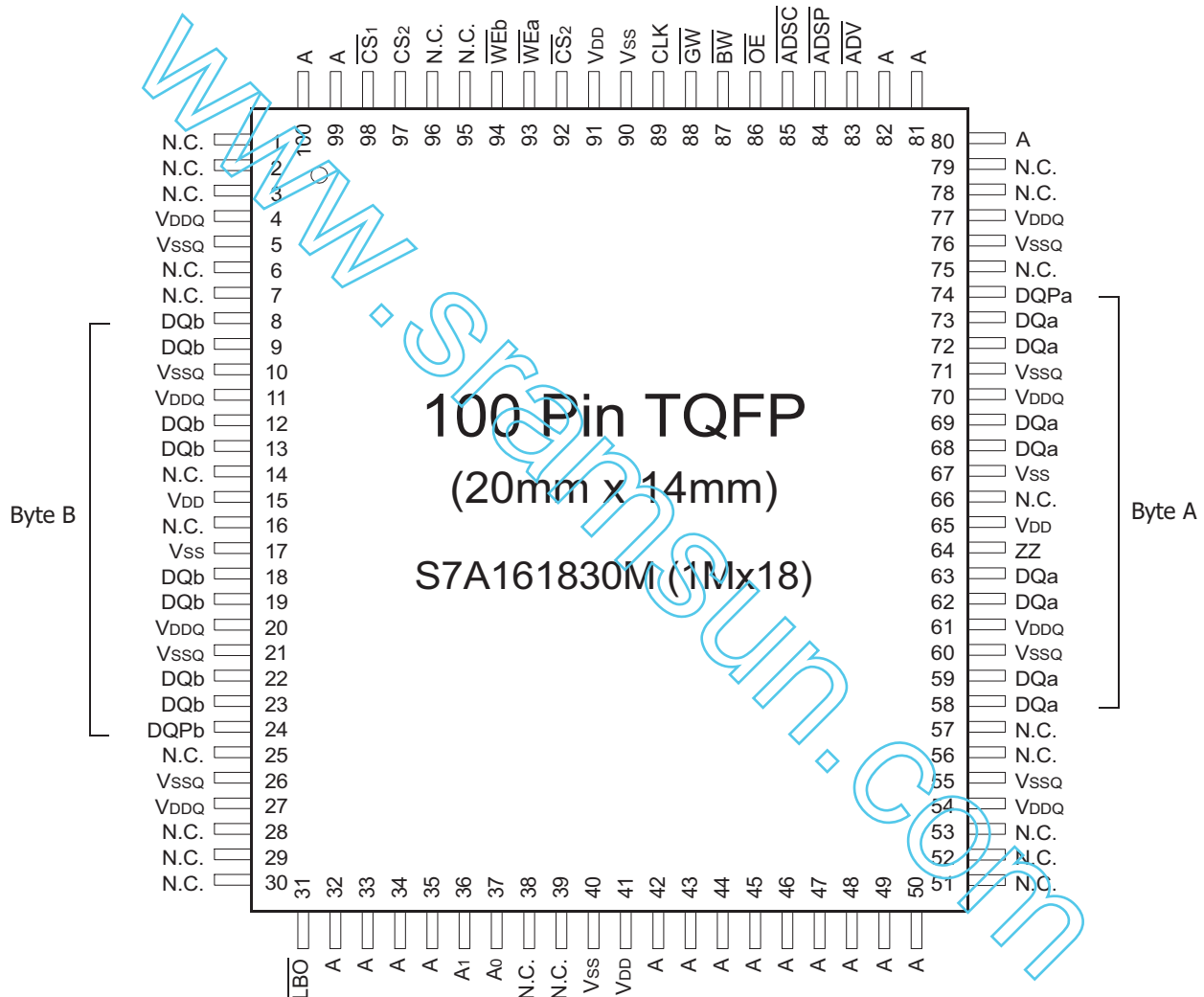

Pin Name

Symbol	Pin Name	TQFP Pin NO.	Symbol	Pin Name	TQFP Pin NO.
A	Address Inputs	32,33,34,35,42,43,44,45,46,47,48,49,50,80,81,82,99,100	VDD	Power Supply (2.5V~3.3V)	15,41,65,91
A0,A1	Burst Address Inputs	37,36	VSS	Ground	17,40,67,90
ADV	Burst Address Advance	83	N.C.	No Connect	1,2,3,6,7,14,16,25,28,29,30,38,39,51,52,53,56,57,66,75,78,79,95,96
ADSP	Address Status Processor	84			
ADSC	Address Status Controller	85			
CLK	Clock	89			
CS1	Chip Select	98	DQa	Data Inputs/Outputs	58,59,62,63,68,69,72,73
CS2	Chip Select	97	DQb		8,9,12,13,18,19,22,23
CS2	Chip Select	92	DQPa, Pb		74,24
WEx(x=a,b)	Byte Write Inputs	93,94	VDDQ	Output Power Supply (2.5V~3.3V)	4,11,20,27,54,61,70,77
OE	Output Enable	86	VSSQ	Output Ground	5,10,21,26,55,60,71,76
GW	Global Write Enable	88			
BW	Byte Write Enable	87			
ZZ	Power Down Input	64			
LBO	Burst Mode Control	31			

NOTE : A0 and A1 are the two least significant bits(LSB) of the address field and set the internal burst counter if burst is desired.

Rev. 1.0 Jul. 2012

Ramsun International Limited
英尚国际有限公司

- 6 -



Function Description

The S7A163630M and S7A161830M are synchronous SRAM designed to support the burst address accessing sequence of the Power PC based microprocessor. All inputs (with the exception of \overline{OE} , \overline{LBO} and \overline{ZZ}) are sampled on rising clock edges. The start and duration of the burst access is controlled by \overline{ADSC} , \overline{ADSP} and \overline{ADV} and chip select pins.

The accesses are enabled with the chip select signals and output enabled signals. Wait states are inserted into the access with \overline{ADV} . When \overline{ZZ} is pulled high, the SRAM will enter a Power Down State. At this time, internal state of the SRAM is preserved. When \overline{ZZ} returns to low, the SRAM normally operates after 2cycles of wake up time. \overline{ZZ} pin is pulled down internally.

Read cycles are initiated with \overline{ADSP} (regardless of \overline{WEx} and \overline{ADSC})using the new external address clocked into the on-chip address register whenever \overline{ADSP} is sampled low, the chip selects are sampled active, and the output buffer is enabled with \overline{OE} . In read operation the data of cell array accessed by the current address, registered in the Data-out registers by the positive edge of \overline{CLK} , are carried to the Data-out buffer by the next positive edge of \overline{CLK} . The data, registered in the Data-out buffer, are projected to the output pins. \overline{ADV} is ignored on the clock edge that samples \overline{ADSP} asserted, but is sampled on the subsequent clock edges. The address increases internally for the next access of the burst when \overline{WEx} are sampled High and \overline{ADV} is sampled low. And \overline{ADSP} is blocked to control signals by disabling $\overline{CS1}$.

All byte write is done by \overline{GW} (regardless of \overline{BW} and \overline{WEx}), and each byte write is performed by the combination of \overline{BW} and \overline{WEx} when \overline{GW} is high.

Write cycles are performed by disabling the output buffers with \overline{OE} and asserting \overline{WEx} . \overline{WEx} are ignored on the clock edge that samples \overline{ADSP} low, but are sampled on the subsequent clock edges. The output buffers are disabled when \overline{WEx} are sampled Low(regardless of \overline{OE}). Data is clocked into the data input register when \overline{WEx} sampled Low. The address increases internally to the next address of burst, if both \overline{WEx} and \overline{ADV} are sampled Low. Individual byte write cycles are performed by any one or more byte write enable signals(\overline{WEa} , \overline{WEb} , \overline{WEc} or \overline{WEd}) sampled low. The \overline{WEa} control \overline{DQa} and \overline{DQPb} , \overline{WEb} controls \overline{DQb} and \overline{DQPa} , \overline{WEc} controls \overline{DQc} and \overline{DQc} , and \overline{WEd} control \overline{DQd} and \overline{DQPd} . Read or write cycle may also be initiated with \overline{ADSC} , instead of \overline{ADSP} . The differences between cycles initiated with \overline{ADSC} and \overline{ADSP} as are follows;

- \overline{ADSP} must be sampled high when \overline{ADSC} is sampled low to initiate a cycle with \overline{ADSC} .
- \overline{WEx} are sampled on the same clock edge that sampled \overline{ADSC} low(and \overline{ADSP} high).

Addresses are generated for the burst access as shown below, The starting point of the burst sequence is provided by the external address. The burst address counter wraps around to its initial state upon completion. The burst sequence is determined by the state of the \overline{LBO} pin. When this pin is Low, linear burst sequence is selected. When this pin is High, Interleaved burst sequence is selected.

Burst Sequence Table

(Interleaved Burst, \overline{LBO} =High)

\overline{LBO} PIN	HIGH	Case 1		Case 2		Case 3		Case 4	
		A1	A0	A1	A0	A1	A0	A1	A0
	First Address	0	0	0	1	1	0	1	1
	↓	0	1	0	0	1	1	1	0
	↓	1	0	1	1	0	0	0	1
	Fourth Address	1	1	1	0	0	1	0	0

(Linear Burst, \overline{LBO} =Low)

\overline{LBO} PIN	LOW	Case 1		Case 2		Case 3		Case 4	
		A1	A0	A1	A0	A1	A0	A1	A0
	First Address	0	0	0	1	1	0	1	1
	↓	0	1	1	0	1	1	0	0
	↓	1	0	1	1	0	0	0	1
	Fourth Address	1	1	0	0	0	1	1	0

Note : 1. \overline{LBO} pin must be tied to High or Low, and Floating State must not be allowed.

Asynchronous Truth Table

Operation	\overline{ZZ}	\overline{OE}	I/O STATUS
Sleep Mode	H	X	High-Z
Read	L	L	DQ
	L	H	High-Z
Write	L	X	Din, High-Z
Deselected	L	X	High-Z

Notes

1. X means "Don't Care".
2. \overline{ZZ} pin is pulled down internally
3. For write cycles that following read cycles, the output buffers must be disabled with \overline{OE} , otherwise data bus contention will occur.
4. Sleep Mode means power down state of which stand-by current does not depend on cycle time.
5. Deselected means power down state of which stand-by current depends on cycle time.

Truth Tables

Synchronous Truth Table

\overline{CS}_1	CS_2	\overline{CS}_2	\overline{ADSP}	\overline{ADSC}	\overline{ADV}	\overline{Write}	CLK	Address Accessed	Operation
H	X	X	X	L	X	X	↑	N/A	Not Selected
L	L	X	L	X	X	X	↑	N/A	Not Selected
L	X	H	L	X	X	X	↑	N/A	Not Selected
L	L	X	X	L	X	X	↑	N/A	Not Selected
L	X	H	X	L	X	X	↑	N/A	Not Selected
L	H	L	L	X	X	X	↑	External Address	Begin Burst Read Cycle
L	H	L	H	L	X	L	↑	External Address	Begin Burst Write Cycle
L	H	L	H	L	X	H	↑	External Address	Begin Burst Read Cycle
X	X	X	H	H	L	H	↑	Next Address	Continue Burst Read Cycle
H	X	X	X	H	L	H	↑	Next Address	Continue Burst Read Cycle
X	X	X	H	H	L	L	↑	Next Address	Continue Burst Write Cycle
H	X	X	X	H	L	L	↑	Next Address	Continue Burst Write Cycle
X	X	X	H	H	H	H	↑	Current Address	Suspend Burst Read Cycle
H	X	X	X	H	H	H	↑	Current Address	Suspend Burst Read Cycle
X	X	X	H	H	H	L	↑	Current Address	Suspend Burst Write Cycle
H	X	X	X	H	H	L	↑	Current Address	Suspend Burst Write Cycle

Notes : 1. X means "Don't Care".

2. The rising edge of clock is symbolized by (↑).

3. $\overline{Write} = L$ means Write operation in Write Truth Table.

$\overline{Write} = H$ means Read operation in Write Truth Table.

4. Operation finally depends on status of asynchronous input pins(ZZ and OE).

Write Truth Table(x36)

\overline{GW}	\overline{BW}	\overline{WEa}	\overline{WEb}	\overline{WEc}	\overline{WEd}	OPERATION
H	H	X	X	X	X	Read
H	L	H	H	H	H	Read
H	L	L	H	H	H	Write Byte A
H	L	H	L	H	H	Write Byte B
H	L	H	H	L	L	Write Byte C And D
H	L	L	L	L	L	Write All Bytes
L	X	X	X	X	X	Write All Bytes

Notes : 1. X means "Don't Care".

2. All inputs in this table must meet setup and hold time around the rising edge of CLK(↑).

Write Truth Table(x18)

\overline{GW}	\overline{BW}	\overline{WEa}	\overline{WEb}	OPERATION
H	H	X	X	Read
H	L	H	H	Read
H	L	L	H	Write Byte A
H	L	H	L	Write Byte B
H	L	L	L	Write All Bytes
L	X	X	X	Write All Bytes

Notes : 1. X means "Don't Care".

2. All inputs in this table must meet setup and hold time around the rising edge of CLK(↑).

Absolute Maximum Ratings

Parameter	Symbol	Rating	Unit	
Voltage on VDD Supply Relative to VSS	VDD	-0.3 to 4.6	V	
Voltage on VDDQ Supply Relative to VSS	VDDQ	VDD	V	
Voltage on Input Pin Relative to VSS	VIN	-0.3 to VDD+0.3	V	
Voltage on I/O Pin Relative to VSS	VIO	-0.3 to VDDQ+0.3	V	
Power Dissipation	PD	1.6	W	
Storage Temperature	TSTG	-65 to 150	°C	
Operating Temperature	Commercial	TOPR	0 to 70	°C
	Industrial	TOPR	-40 to 85	°C
Storage Temperature Range Under Bias	TBIAS	-10 to 85	°C	

Notes : Stresses greater than those listed under "Absolute Maximum Ratings" may cause permanent damage to the device. This is a stress rating only and functional operation of the device at these or any other conditions above those indicated in the operating sections of this specification is not implied. Exposure to absolute maximum rating conditions for extended periods may affect reliability.

Operating Conditions (0°C ≤ TA ≤ 70°C)

Parameter	Symbol	Min	Typ.	Max	Unit
Supply Voltage	VDD1	2.3	2.5	2.7	V
	VDDQ1	2.3	2.5	2.7	V
	VDD2	3.1	3.3	3.5	V
	VDDQ2	2.3	3.3	3.5	V
Ground	VSS	0	0	0	V

Notes: 1. The above parameters are also guaranteed at industrial temperature range.
2. It should be VDDQ ≤ VDD

Capacitance (TA=25°C, f=1MHz)

Parameter	Symbol	Test Condition	Min	Max	Unit
Input Capacitance	CIN	VIN=0V	-	5	pF
Output Capacitance	COUT	VOUT=0V	-	7	pF

Note : Sampled not 100% tested.

Overshoot Timing

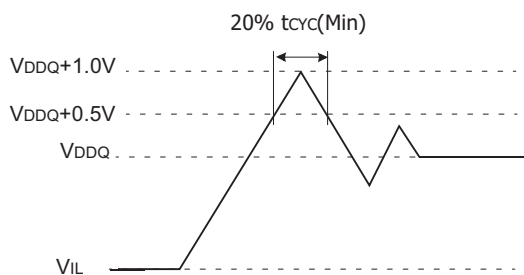

Undershoot Timing

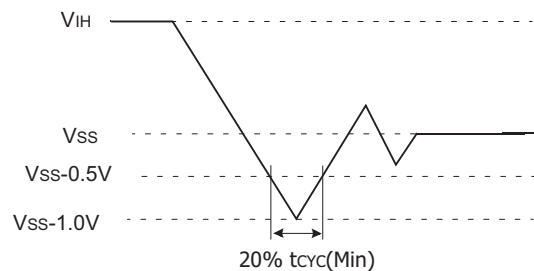

DC Electrical Characteristics

Parameter	Symbol	Test Conditions	Min	Max	Unit	Notes	
Input Leakage Current(except ZZ)	IIL	VDD=Max ; VIN=VSS to VDD	-2	+2	uA		
Output Leakage Current	IOL	Output Disabled, Vout=VSS to VDDQ	-2	+2	uA		
Operating Current	ICC	Device Selected, IOUT=0mA, ZZ ≤ VIL, Cycle Time ≥ tcyc Min	-25	-	150	mA	1,2
			-16	-	110		
Standby Current	ISB	Device deselected, IOUT=0mA, ZZ ≤ VIL, f=Max, All Inputs ≤ VIL or ≥ VIH	-25	-	50	mA	
			-16	-	45		
	ISB1	Device deselected, IOUT=0mA, ZZ ≤ 0.2V, f=0, All Inputs=fixed (VDD-0.2V or 0.2V)	-	-	35	mA	
ISB2	Device deselected, IOUT=0mA, ZZ ≥ VDD-0.2V, f=Max, All Inputs ≤ VIL or ≥ VIH	-	-	35			
Output Low Voltage(3.3V I/O)	VOL	IOL=8.0mA	-	0.4	V		
Output High Voltage(3.3V I/O)	VOH	IOH=-4.0mA	2.4	-	V		
Output Low Voltage(2.5V I/O)	VOL	IOL=1.0mA	-	0.4	V		
Output High Voltage(2.5V I/O)	VOH	IOH=-1.0mA	2.0	-	V		
Input Low Voltage(3.3V I/O)	VIL		-0.3*	0.8	V		
Input High Voltage(3.3V I/O)	VIH		2.0	VDD+0.3**	V	3	
Input Low Voltage(2.5V I/O)	VIL		-0.3*	0.7	V		
Input High Voltage(2.5V I/O)	VIH		1.7	VDD+0.3**	V	3	

Notes : The above parameters are also guaranteed at industrial temperature range.
 1. Reference AC Operating Conditions and Characteristics for input and timing.
 2. Data states are all zero.
 3. In Case of I/O Pins, the Max. VIH=VDDQ+0.3V

Test Conditions

Parameter	Value
Input Pulse Level(for 3.3V I/O)	0 to 3.0V
Input Pulse Level(for 2.5V I/O)	0 to 2.5V
Input Rise and Fall Time(Measured at 20% to 80% for 3.3/2.5V I/O)	1.0V/ns
Input and Output Timing Reference Levels for 3.3V I/O	1.5V
Input and Output Timing Reference Levels for 2.5V I/O	VDDQ/2
Output Load	See Fig. 1

The above parameters are also guaranteed at industrial temperature range.

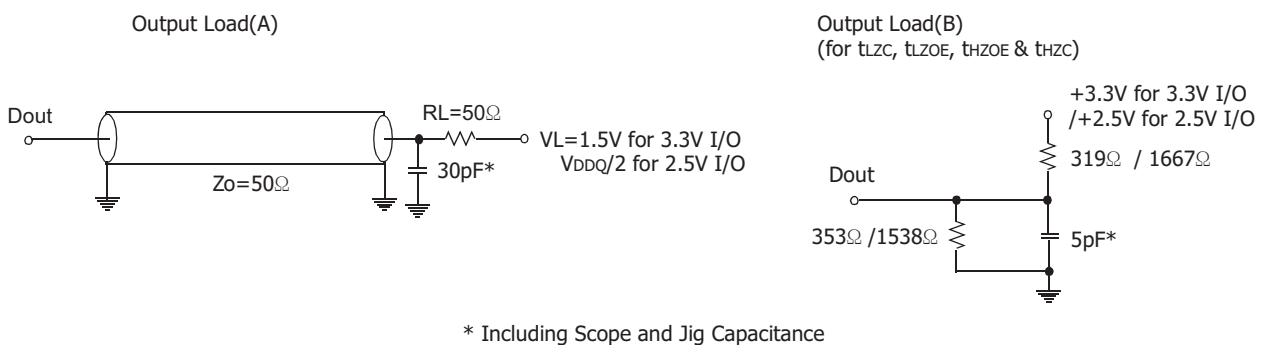

Fig. 1

AC Timing Characteristics

Parameter	Symbol	-25		-16		Unit
		Min	Max	Min	Max	
Cycle Time	t _{CYC}	4.0	-	6.0	-	ns
Clock Access Time	t _{CD}	-	2.6	-	3.5	ns
Output Enable to Data Valid	t _{OE}	-	2.6	-	3.5	ns
Clock High to Output Low-Z	t _{LZC}	1.5	-	1.5	-	ns
Output Hold from Clock High	t _{OH}	1.5	-	1.5	-	ns
Output Enable Low to Output Low-Z	t _{LZOE}	0	-	0	-	ns
Output Enable High to Output High-Z	t _{HZOE}	-	2.6	-	3.0	ns
Clock High to Output High-Z	t _{HZC}	-	2.6	-	3.0	ns
Clock High Pulse Width	t _{CH}	1.7	-	2.2	-	ns
Clock Low Pulse Width	t _{CL}	1.7	-	2.2	-	ns
Address Setup to Clock High	t _{AS}	1.2	-	1.5	-	ns
Address Status Setup to Clock High	t _{SS}	1.2	-	1.5	-	ns
Data Setup to Clock High	t _{DS}	1.2	-	1.5	-	ns
Write Setup to Clock High (\overline{WE} , \overline{BWx})	t _{WS}	1.2	-	1.5	-	ns
Address Advance Setup to Clock High	t _{ADVS}	1.2	-	1.5	-	ns
Chip Select Setup to Clock High	t _{CSS}	1.2	-	1.5	-	ns
Address Hold from Clock High	t _{AH}	0.3	-	0.5	-	ns
Address Status Hold from Clock High	t _{SH}	0.3	-	0.5	-	ns
Data Hold from Clock High	t _{DH}	0.3	-	0.5	-	ns
Write Hold from Clock High (\overline{WE} , \overline{BWx})	t _{WH}	0.3	-	0.5	-	ns
Address Advance Hold from Clock High	t _{ADVH}	0.3	-	0.5	-	ns
Chip Select Hold from Clock High	t _{CSH}	0.3	-	0.5	-	ns
ZZ High to Power Down	t _{PD5}	2	-	2	-	cycle
ZZ Low to Power Up	t _{PUS}	2	-	2	-	cycle

- Notes :**
1. The above parameters are also guaranteed at industrial temperature range.
 2. All address inputs must meet the specified setup and hold times for all rising clock edges whenever \overline{ADSC} and/or \overline{ADSP} is sampled low and \overline{CS} is sampled low. All other synchronous inputs must meet the specified setup and hold times whenever this device is chip selected.
 3. Both chip selects must be active whenever \overline{ADSC} or \overline{ADSP} is sampled low in order for the this device to remain enabled.
 4. \overline{ADSC} or \overline{ADSP} must not be asserted for at least 2 Clock after leaving ZZ state.

Sleep Mode

Sleep Mode is a low current, power-down mode in which the device is deselected and current is reduced to I_{SB2} . The duration of Sleep Mode is dictated by the length of time the ZZ is in a High state.

After entering Sleep Mode, all inputs except ZZ become disabled and all outputs go to High-Z.

The ZZ pin is an asynchronous, active high input that causes the device to enter Sleep Mode.

When the ZZ pin becomes a logic High, I_{SB2} is guaranteed after the time t_{ZZI} is met. Any operation pending when entering Sleep Mode is not guaranteed to successful complete. Therefore, Sleep Mode (Read or Write) must not be initiated until valid pending operations are completed. Similarly, when exiting Sleep Mode during t_{PUS} , only a Deselect or Read cycle should be given while the SRAM is transitioning out of Sleep Mode.

Sleep Mode Electrical Characteristics

Description	Condition	Symbol	Min	Max	Unit
Current during SLEEP MODE	$ZZ \geq V_{IH}$	I_{SB2}		35	mA
ZZ active to input ignored		t_{PDS}	2		cycle
ZZ inactive to input sampled		t_{PUS}	2		cycle
ZZ active to SLEEP current		t_{ZZI}		2	cycle
ZZ inactive to exit SLEEP current		t_{RZZI}	0		

Sleep Mode Waveform

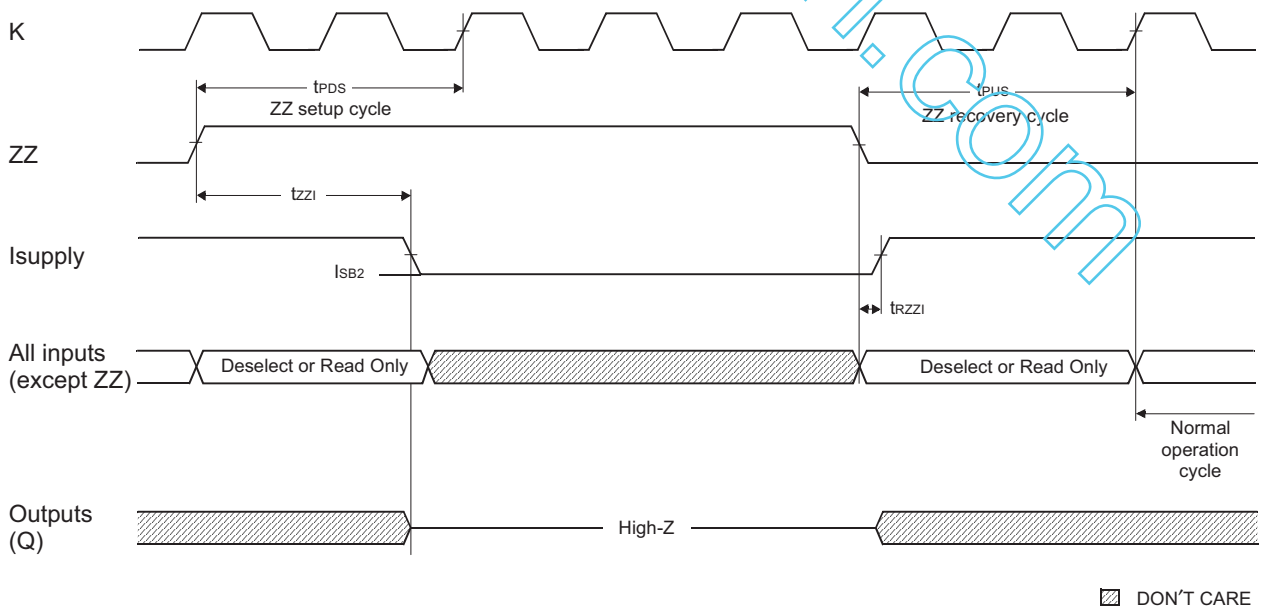

Timing Waveform of Read Cycle

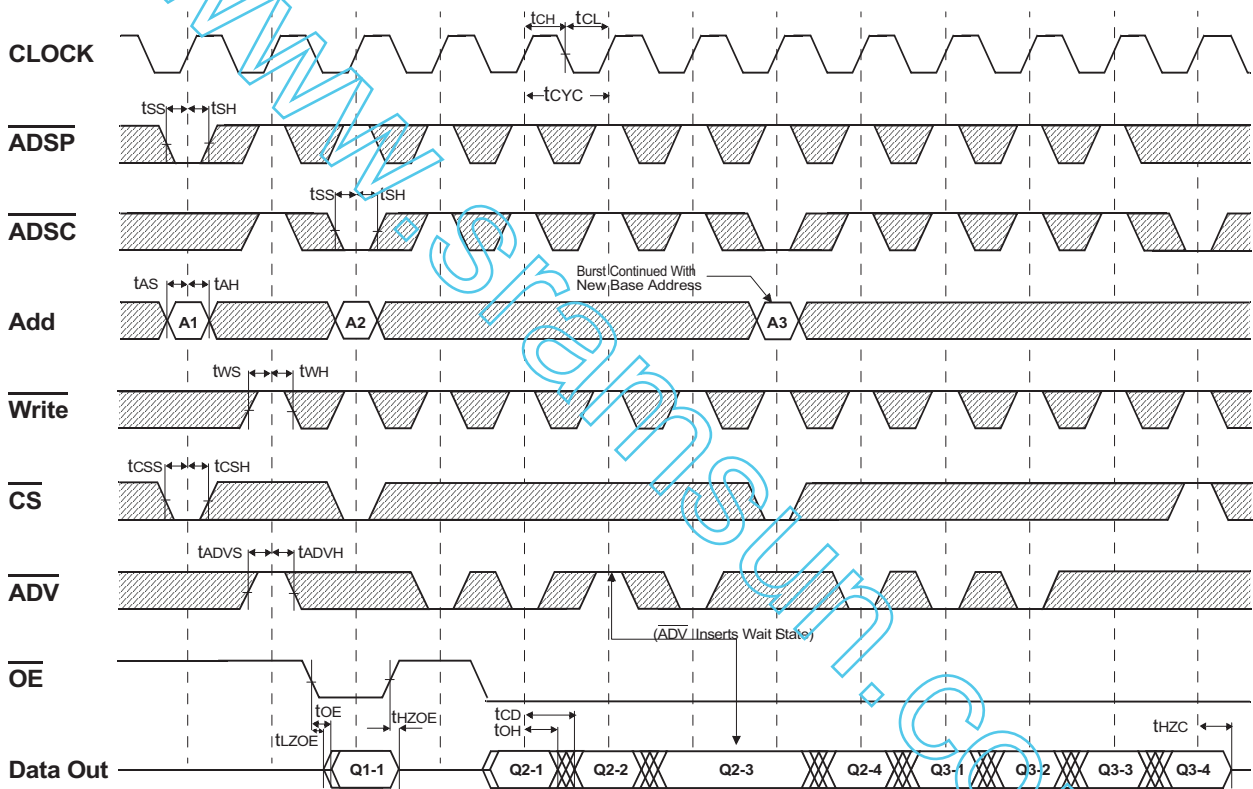

NOTES: $\overline{\text{Write}} = L$ means $\text{GW} = L$, or $\text{GW} = H$, $\text{BW} = L$, $\text{WEX} = L$ Don't Care
 $\overline{\text{CS}} = L$ means $\text{CS}_1 = L$, $\text{CS}_2 = H$ and $\overline{\text{CS}}_2 = L$ Undefined
 $\overline{\text{CS}} = H$ means $\overline{\text{CS}}_1 = H$, or $\overline{\text{CS}}_1 = L$ and $\overline{\text{CS}}_2 = H$, or $\overline{\text{CS}}_1 = L$, and $\text{CS}_2 = L$

Timing Waveform of Write Cycle

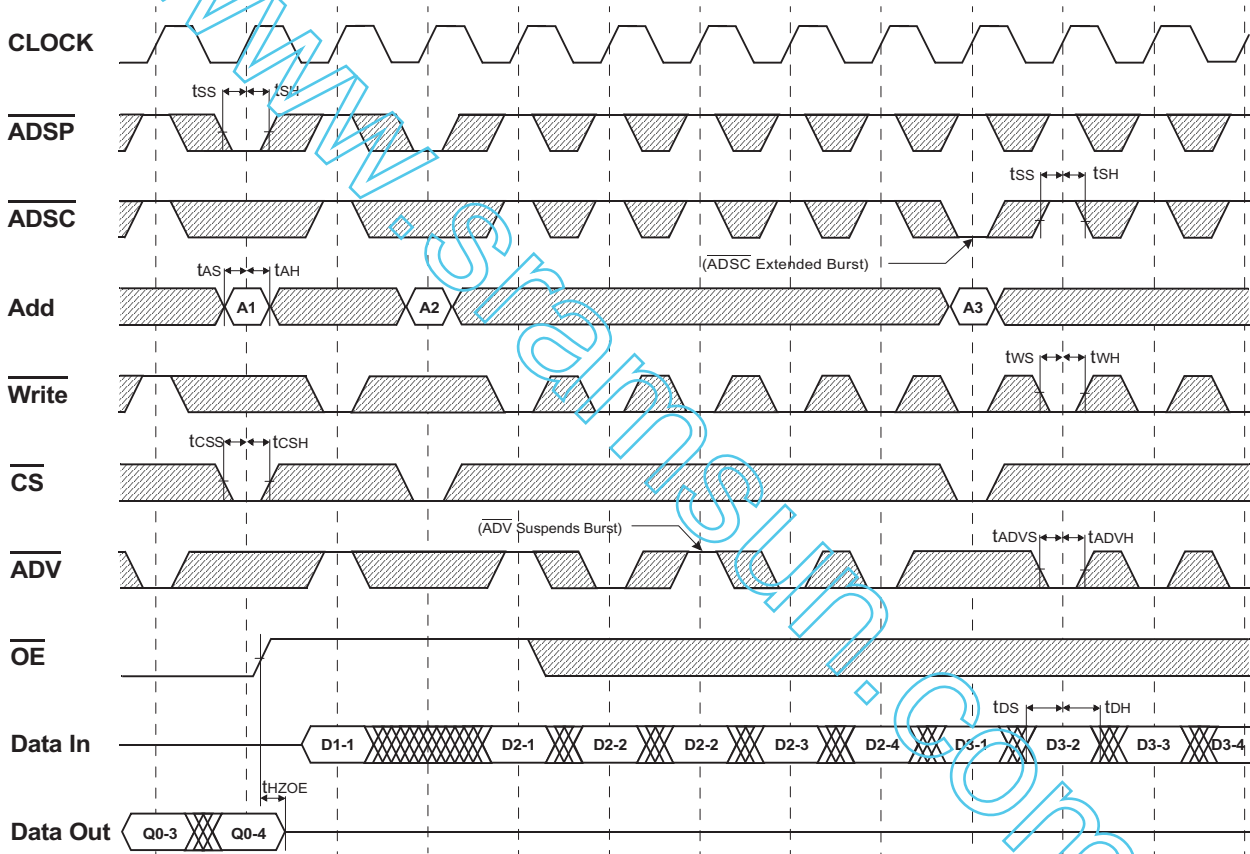

NOTES: $\overline{\text{Write}} = L$ means $\overline{\text{GW}} = L$, or $\overline{\text{GW}} = H$, $\overline{\text{BW}} = L$, $\overline{\text{WEX}} = L$
 $\overline{\text{CS}} = L$ means $\overline{\text{CS}}_1 = L$, $\overline{\text{CS}}_2 = H$ and $\overline{\text{CS}}_2 = L$
 $\overline{\text{CS}} = H$ means $\overline{\text{CS}}_1 = H$, or $\overline{\text{CS}}_1 = L$ and $\overline{\text{CS}}_2 = H$, or $\overline{\text{CS}}_1 = L$, and $\overline{\text{CS}}_2 = L$

☐ Don't Care
 ☒ Undefined

Timing Waveform of Combination Read/Write Cycle(ADSP Controlled , ADSC=High)

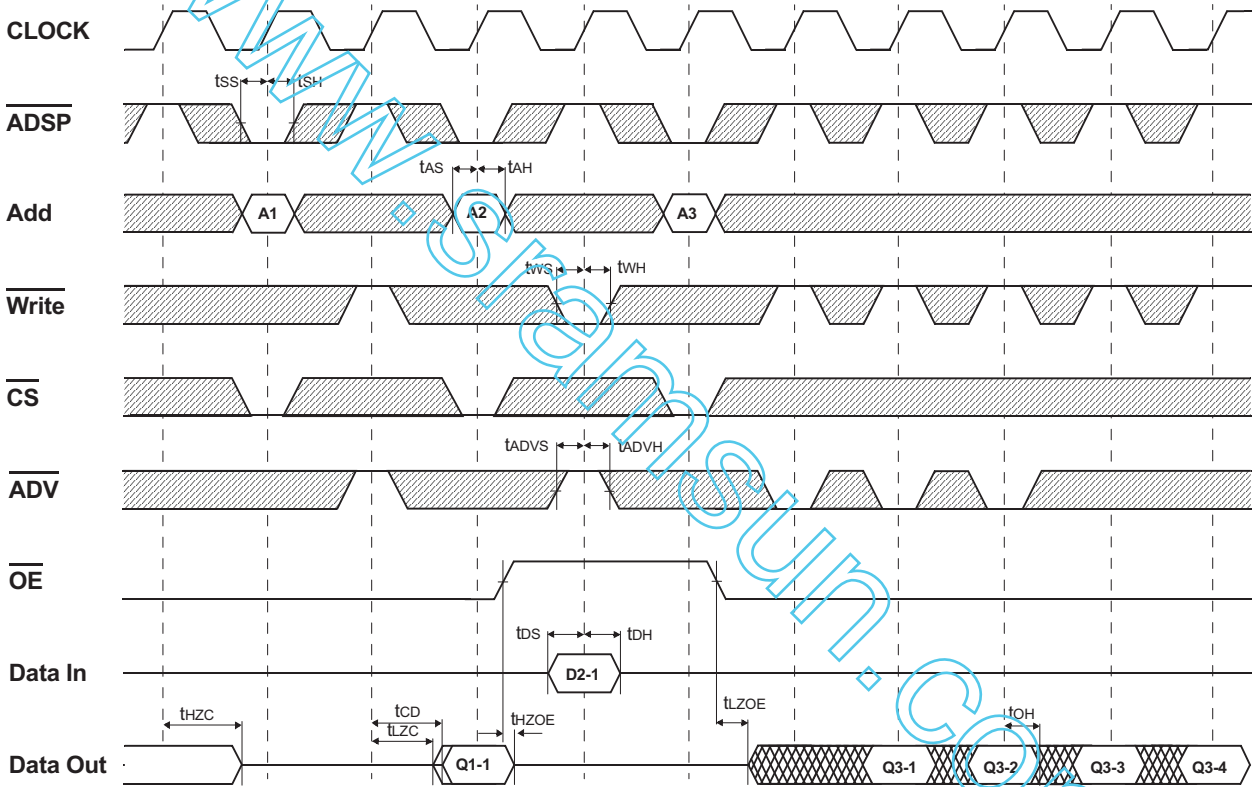

NOTES: $\overline{\text{Write}} = \text{L}$ means $\overline{\text{GW}} = \text{L}$, or $\overline{\text{GW}} = \text{H}$, $\overline{\text{BW}} = \text{L}$, $\overline{\text{WEX}} = \text{L}$
 $\overline{\text{CS}} = \text{L}$ means $\overline{\text{CS}}_1 = \text{L}$, $\overline{\text{CS}}_2 = \text{H}$ and $\overline{\text{CS}}_2 = \text{L}$
 $\overline{\text{CS}} = \text{H}$ means $\overline{\text{CS}}_1 = \text{H}$, or $\overline{\text{CS}}_1 = \text{L}$ and $\overline{\text{CS}}_2 = \text{H}$, or $\overline{\text{CS}}_1 = \text{L}$, and $\overline{\text{CS}}_2 = \text{L}$

Don't Care
 Undefined

Timing Waveform of Single Read/Write Cycle ($\overline{\text{ADSC}}$ Controlled, $\overline{\text{ADSP}}=\text{High}$)

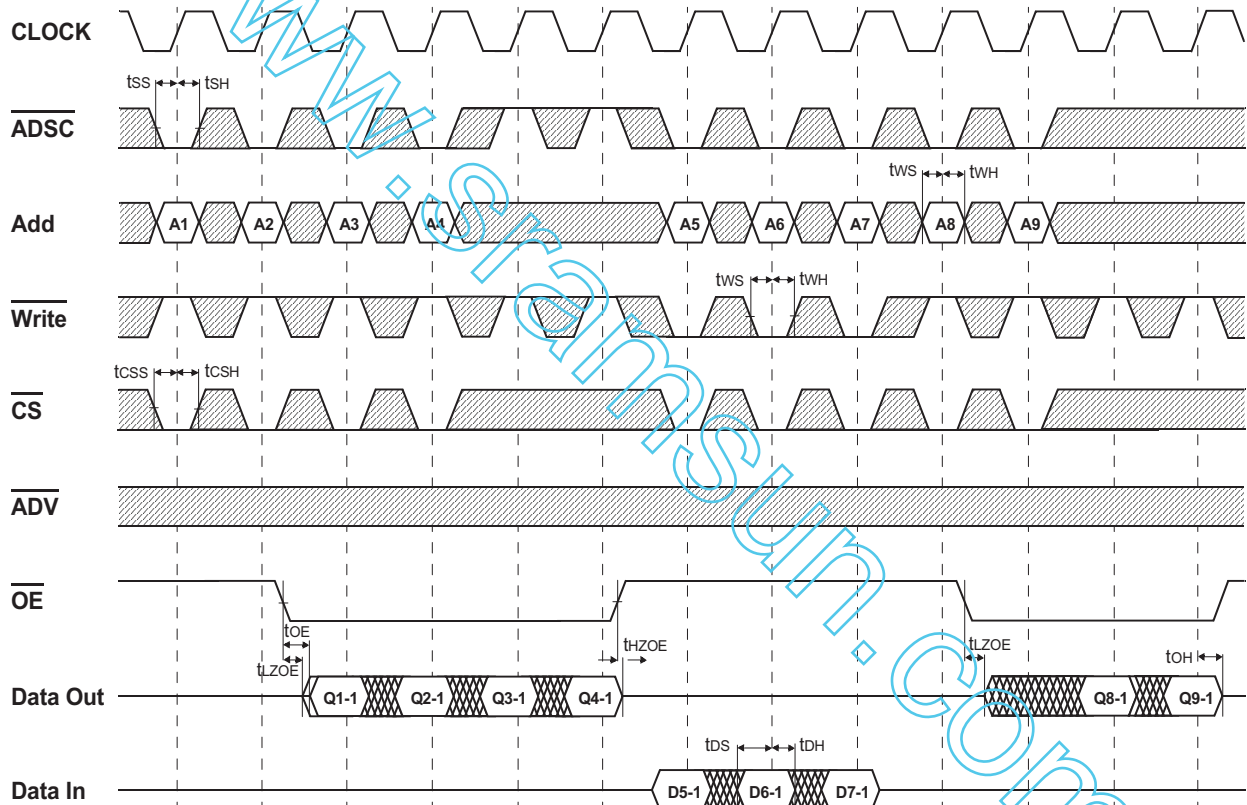

NOTES: $\overline{\text{Write}} = \text{L}$ means $\text{GW} = \text{L}$, or $\text{GW} = \text{H}$, $\text{BW} = \text{L}$, $\text{WEx} = \text{L}$
 $\overline{\text{CS}} = \text{L}$ means $\overline{\text{CS}}_1 = \text{L}$, $\text{CS}_2 = \text{H}$ and $\overline{\text{CS}}_2 = \text{L}$
 $\overline{\text{CS}} = \text{H}$ means $\overline{\text{CS}}_1 = \text{H}$, or $\overline{\text{CS}}_1 = \text{L}$ and $\overline{\text{CS}}_2 = \text{H}$, or $\overline{\text{CS}}_1 = \text{L}$, and $\text{CS}_2 = \text{L}$

□ Don't Care
 ⊠ Undefined

Timing Waveform of Power Down Cycle

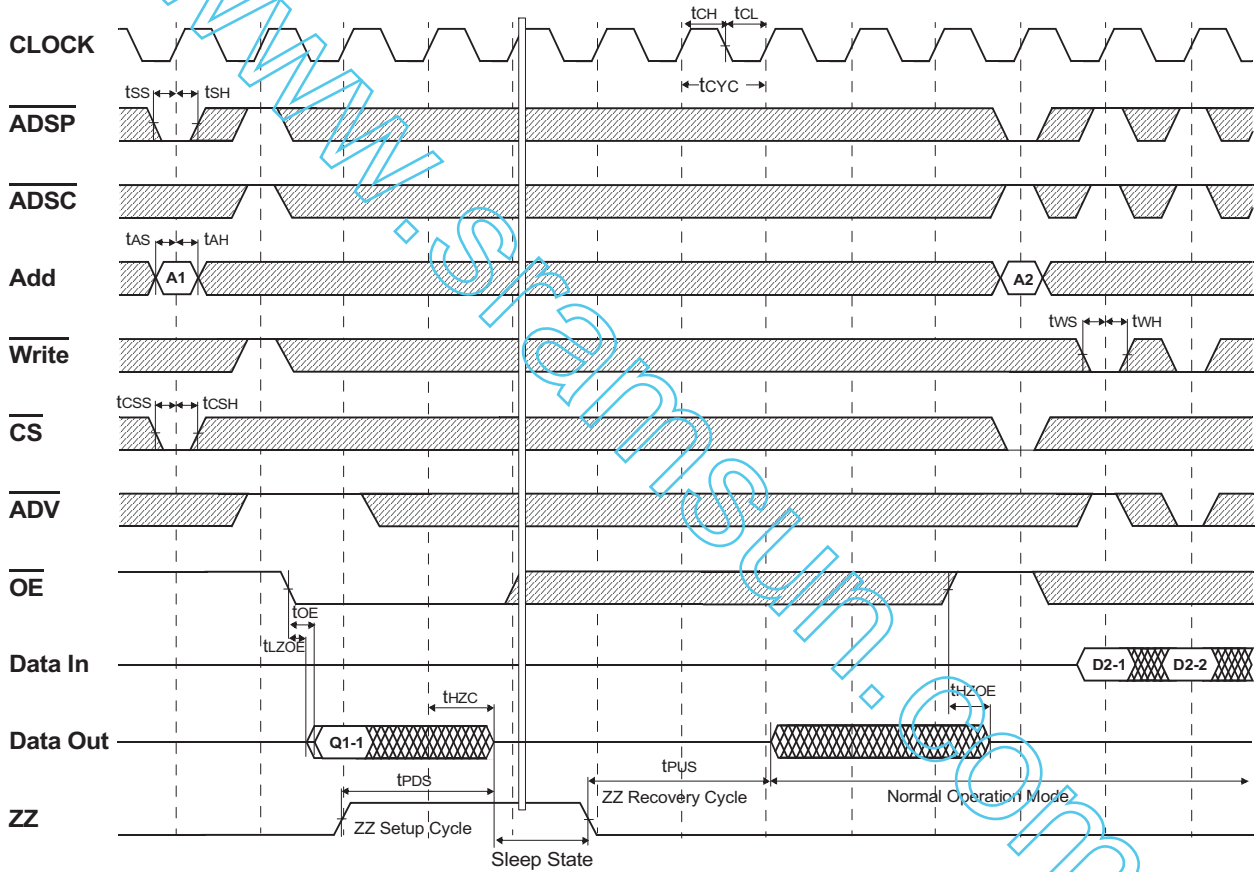

NOTES: $\overline{\text{Write}} = \text{L}$ means $\text{GW} = \text{L}$, or $\text{GW} = \text{H}$, $\text{BW} = \text{L}$, $\text{WEx} = \text{L}$
 $\text{CS} = \text{L}$ means $\text{CS}_1 = \text{L}$, $\text{CS}_2 = \text{H}$ and $\overline{\text{CS}}_2 = \text{L}$
 $\text{CS} = \text{H}$ means $\text{CS}_1 = \text{H}$, or $\overline{\text{CS}}_1 = \text{L}$ and $\text{CS}_2 = \text{H}$, or $\overline{\text{CS}}_1 = \text{L}$, and $\text{CS}_2 = \text{L}$

☐ Don't Care
 ☒ Undefined

Application Information

Depth Expansion

The Netsol 512Kx36 Synchronous Pipelined Burst SRAM has two additional chip selects for simple depth expansion. This permits easy secondary cache upgrades from 512K depth to 1M depth without extra logic.

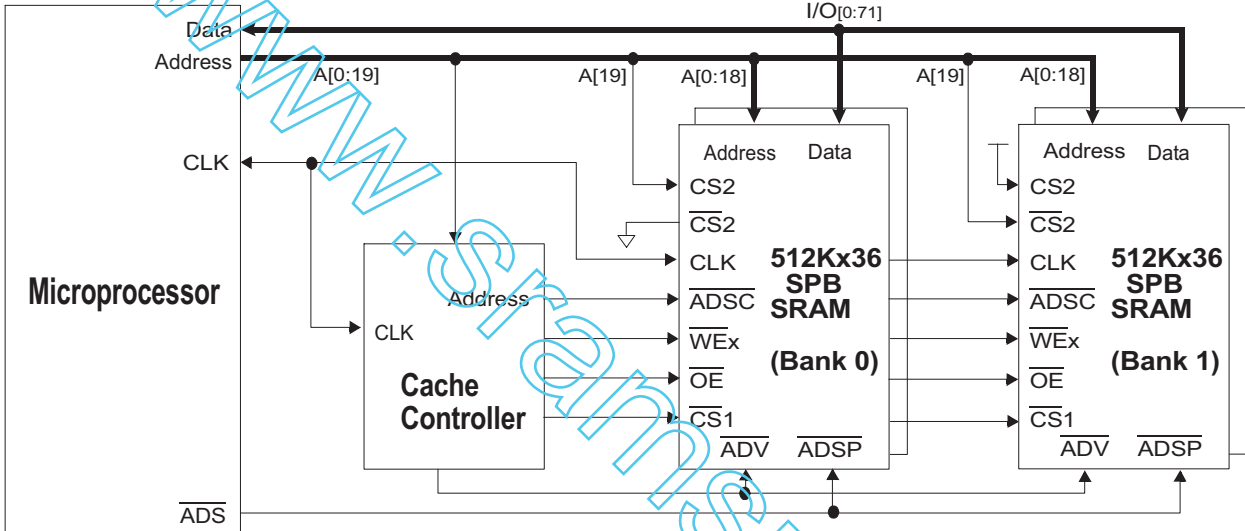

Interleave Read Timing (Refer to non-interleave write timing for interleave write timing)

(ADSP Controlled, ADSC=High)

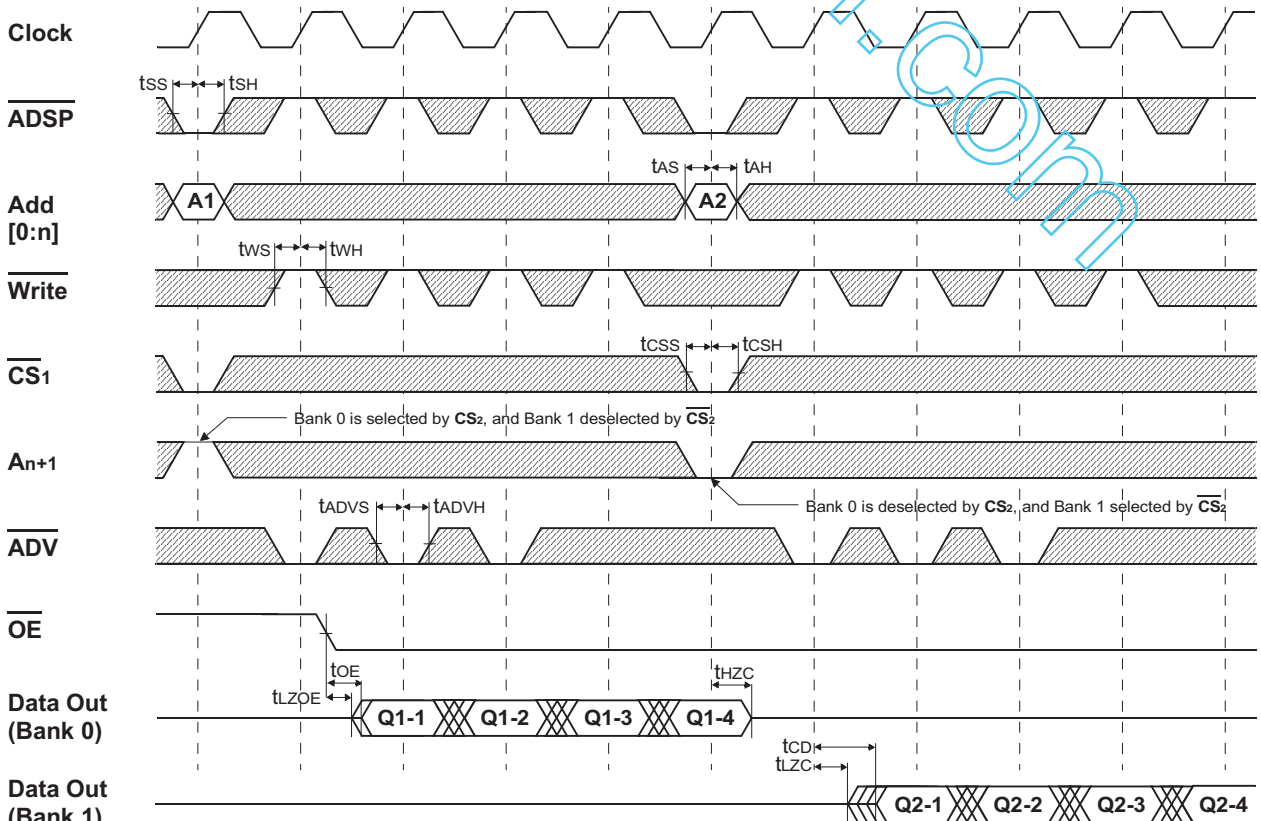

*Notes : n = 14 32K depth, 15 64K depth
16 128K depth, 17 256K depth
18 512K depth, 19 1M depth

☐ Don't Care ☒ Undefined

Application Information

Depth Expansion

The Netsol 1Mx18 Synchronous Pipelined Burst SRAM has two additional chip selects for simple depth expansion. This permits easy secondary cache upgrades from 1M depth to 2M depth without extra logic.

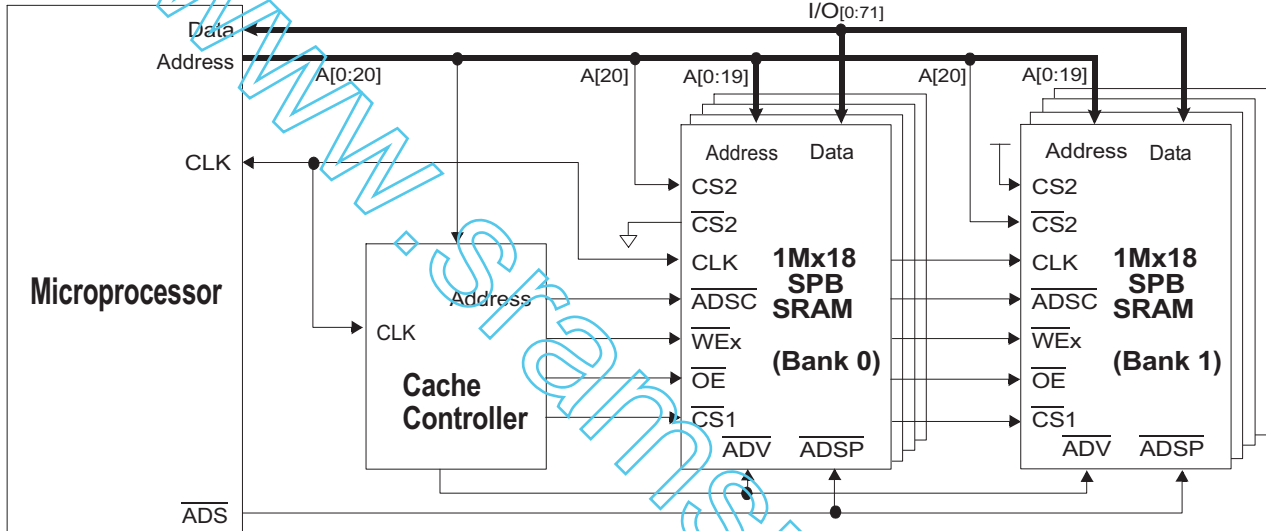

Interleave Read Timing (Refer to non-interleave write timing for interleave write timing)

(ADSP Controlled, ADSC=High)

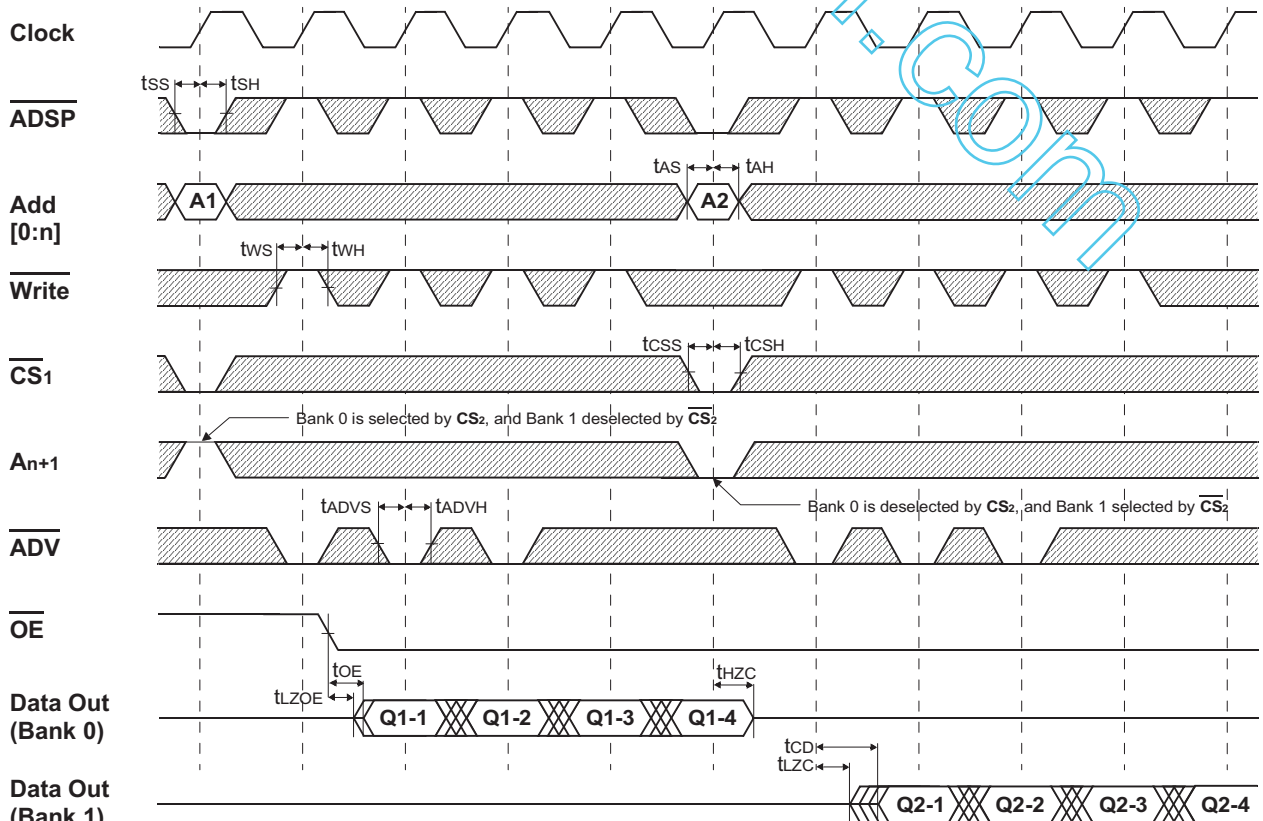

*Notes : n = 14 32K depth, 15 64K depth
16 128K depth, 17 256K depth
18 512K depth, 19 1M depth
20 2M depth

☐ Don't Care ☒ Undefined

Package Dimensions

