

FEATURES

- No write delays
- Unlimited write endurance
- Data retention greater than 20 years
- Automatic data protection on power loss
- Block write protection
- Fast, simple SPI interface with up to 40 MHz clock rate
- 2.7 to 3.6 Volt power supply range
- Low current sleep mode
- Industrial temperatures
- Available in 8-pin DFN or 8-pin DFN Small Flag RoHS-compliant packages
- Direct replacement for serial EEPROM, Flash, FeRAM
- AEC-Q100 Grade 1 Option



DFN



Small Flag DFN

INTRODUCTION

The **MR25H10** is a 1,048,576-bit magnetoresistive random access memory (MRAM) device organized as 131,072 words of 8 bits. The **MR25H10** offers serial EEPROM and serial Flash compatible read/write timing with no write delays and unlimited read/write endurance.



Unlike other serial memories, both reads and writes can occur randomly in memory with no delay between writes. The **MR25H10** is the ideal memory solution for applications that must store and retrieve data and programs quickly using a small number of I/O pins.

The **MR25H10** is available in either a 5 mm x 6 mm 8-pin DFN package or a 5 mm x 6 mm 8-pin DFN Small Flag package. Both are compatible with serial EEPROM, Flash, and FeRAM products.

The **MR25H10** provides highly reliable data storage over a wide range of temperatures. The product is offered with Industrial (-40° to +85 °C) and AEC-Q100 Grade 1 (-40°C to +125 °C) operating temperature range options.

CONTENTS

1. DEVICE PIN ASSIGNMENT.....	2
2. SPI COMMUNICATIONS PROTOCOL.....	4
3. ELECTRICAL SPECIFICATIONS.....	10
4. TIMING SPECIFICATIONS.....	12
5. ORDERING INFORMATION.....	12
6. MECHANICAL DRAWING.....	13
7. REVISION HISTORY.....	15
How to Reach Us.....	15

1. DEVICE PIN ASSIGNMENT

Overview

The MR25H10 is a serial MRAM with memory array logically organized as 128Kx8 using the four pin interface of chip select (\overline{CS}), serial input (SI), serial output (SO) and serial clock (SCK) of the serial peripheral interface (SPI) bus. Serial MRAM implements a subset of commands common to today's SPI EEPROM and Flash components allowing MRAM to replace these components in the same socket and interoperate on a shared SPI bus. Serial MRAM offers superior write speed, unlimited endurance, low standby & operating power, and more reliable data retention compared to available serial memory alternatives.

Figure 1.1 Block Diagram

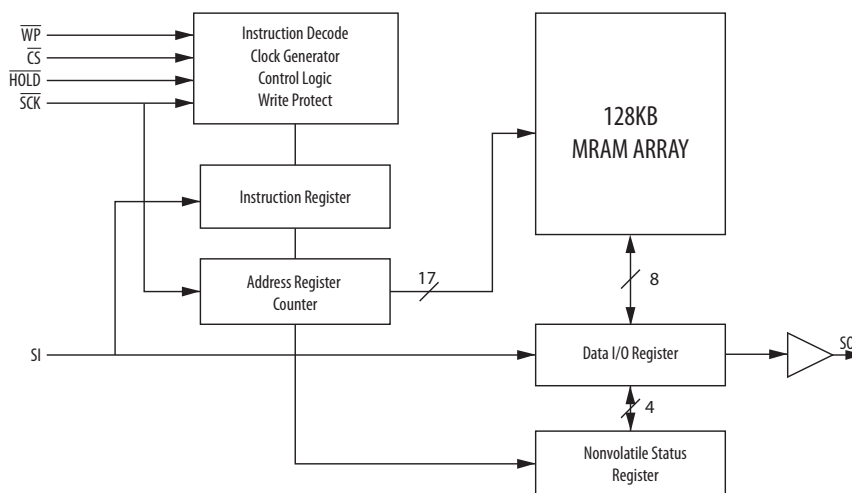

System Configuration

Single or multiple devices can be connected to the bus as shown in Figure 1.2. Pins SCK, SO and SI are common among devices. Each device requires \overline{CS} and \overline{HOLD} pins to be driven separately.

Figure 1.2 System Configuration

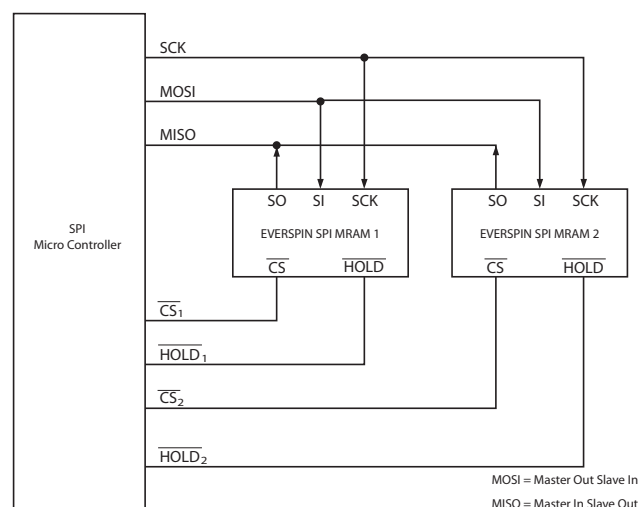

DEVICE PIN ASSIGNMENT

Figure 1.3 Pin Diagrams (Top View)

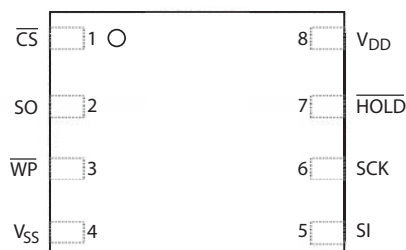

8-Pin DFN or 8-Pin DFN Small Flag Package

Table 1.1 Pin Functions

Signal Name	Pin	I/O	Function	Description
$\overline{\text{CS}}$	1	Input	Chip Select	An active low chip select for the serial MRAM. When chip select is high, the memory is powered down to minimize standby power, inputs are ignored and the serial output pin is Hi-Z. Multiple serial memories can share a common set of data pins by using a unique chip select for each memory.
SO	2	Output	Serial Output	The data output pin is driven during a read operation and remains Hi-Z at all other times. SO is Hi-Z when HOLD is low. Data transitions on the data output occur on the falling edge of SCK.
$\overline{\text{WP}}$	3	Input	Hold	A low on the write protect input prevents write operations to the Status Register.
V_{SS}	4	Supply	Ground	Power supply ground pin.
SI	5	Input	Serial Input	All data is input to the device through this pin. This pin is sampled on the rising edge of SCK and ignored at other times. SI can be tied to SO to create a single bidirectional data bus if desired.
SCK	6	Input	Serial Clock	Synchronizes the operation of the MRAM. The clock can operate up to 40 MHz to shift commands, address, and data into the memory. Inputs are captured on the rising edge of clock. Data outputs from the MRAM occur on the falling edge of clock. The serial MRAM supports both SPI Mode 0 (CPOL=0, CPHA=0) and Mode 3 (CPOL=1, CPHA=1). In Mode 0, the clock is normally low. In Mode 3, the clock is normally high. Memory operation is static so the clock can be stopped at any time.
$\overline{\text{HOLD}}$	7	Input	Hold	A low on the Hold pin interrupts a memory operation for another task. When HOLD is low, the current operation is suspended. The device will ignore transitions on the $\overline{\text{CS}}$ and SCK when HOLD is low. All transitions of HOLD must occur while $\overline{\text{CS}}$ is low.
V_{DD}	8	Supply	Power Supply	Power supply voltage from +2.7 to +3.6 volts.

2. SPI COMMUNICATIONS PROTOCOL

MR25H10 can be operated in either SPI Mode 0 (CPOL=0, CPHA =0) or SPI Mode 3 (CPOL=1, CPHA=1). For both modes, inputs are captured on the rising edge of the clock and data outputs occur on the falling edge of the clock. When not conveying data, SCK remains low for Mode 0; while in Mode 3, SCK is high. The memory determines the mode of operation (Mode 0 or Mode 3) based upon the state of the SCK when \overline{CS} falls.

All memory transactions start when \overline{CS} is brought low to the memory. The first byte is a command code. Depending upon the command, subsequent bytes of address are input. Data is either input or output. There is only one command performed per \overline{CS} active period. \overline{CS} must go inactive before another command can be accepted. To ensure proper part operation according to specifications, it is necessary to terminate each access by raising \overline{CS} at the end of a byte (a multiple of 8 clock cycles from \overline{CS} dropping) to avoid partial or aborted accesses.

Table 2.1 Command Codes

Instruction	Description	Binary Code	Hex Code	Address Bytes	Data Bytes
WREN	Write Enable	0000 0110	06h	0	0
WRDI	Write Disable	0000 0100	04h	0	0
RDSR	Read Status Register	0000 0101	05h	0	1
WRSR	Write Status Register	0000 0001	01h	0	1
READ	Read Data Bytes	0000 0011	03h	3	1 to ∞
WRITE	Write Data Bytes	0000 0010	02h	3	1 to ∞
SLEEP	Enter Sleep Mode	1011 1001	B9h	0	0
WAKE	Exit Sleep Mode	1010 1011	ABh	0	0

Status Register and Block Write Protection

The status register consists of the 8 bits listed in table 2.2. Status register bits BP0 and BP1 define the memory block arrays that are protected as described in table 2.3. The Status Register Write Disable bit (SRWD) is used in conjunction with bit 1 (WEL) and the Write Protection pin (WP) as shown in table 2.4 to enable writes to status register bits. The fast writing speed of MR25H10 does not require write status bits. The state of bits 6,5,4, and 0 can be user modified and do not affect memory operation. All bits in the status register are pre-set from the factory to the "0" state.

Table 2.2 Status Register Bit Assignments

Bit 7	Bit 6	Bit 5	Bit 4	Bit 3	Bit 2	Bit 1	Bit 0
SRWD	Don't Care	Don't Care	Don't Care	BP1	BP0	WEL	Don't Care

Table 2.3 Block Memory Write Protection

Status Register		Memory Contents	
BP1	BP0	Protected Area	Unprotected Area
0	0	None	All Memory
0	1	Upper Quarter	Lower Three-Quarters
1	0	Upper Half	Lower Half
1	1	All	None

Table 2.4 Memory Protection Modes

WEL	SRWD	\overline{WP}	Protected Blocks	Unprotected Blocks	Status Register
0	X	X	Protected	Protected	Protected
1	0	X	Protected	Writable	Writable
1	1	Low	Protected	Writable	Protected
1	1	High	Protected	Writable	Writable

When WEL is reset to 0, writes to all blocks and the status register are protected. When WEL is set to 1, BP0 and BP1 determine which memory blocks are protected. While SRWD is reset to 0 and WEL is set to 1, status register bits BP0 and BP1 can be modified. Once SRWD is set to 1, WP must be high to modify SRWD, BP0 and BP1.

Read Status Register (RDSR)

The Read Status Register (RDSR) command allows the Status Register to be read. The Status Register can be read at any time to check the status of write enable latch bit, status register write protect bit, and block write protect bits. For MR25H10, the write in progress bit (bit 0) is not written by the memory because there is no write delay. The RDSR command is entered by driving \overline{CS} low, sending the command code, and then driving \overline{CS} high.

Figure 2.1 RDSR

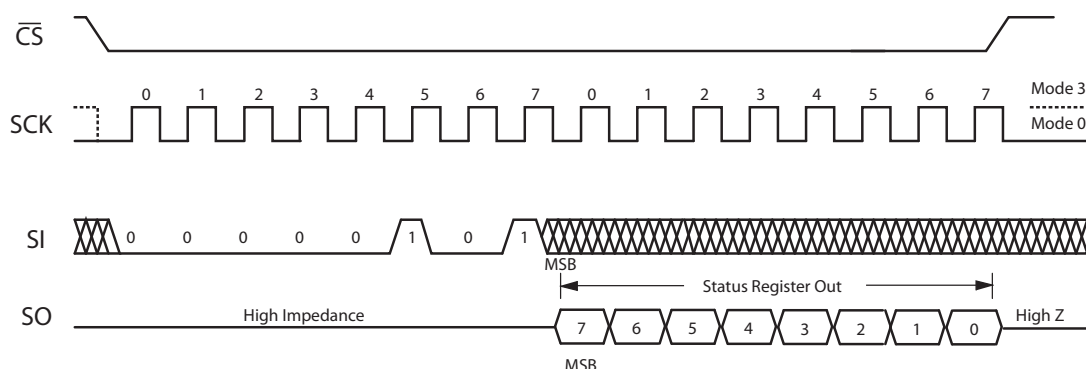

SPI COMMUNICATIONS PROTOCOL

Write Enable (WREN)

The Write Enable (WREN) command sets the Write Enable Latch (WEL) bit in the status register to 1. The WEL bit must be set prior to writing in the status register or the memory. The WREN command is entered by driving \overline{CS} low, sending the command code, and then driving \overline{CS} high.

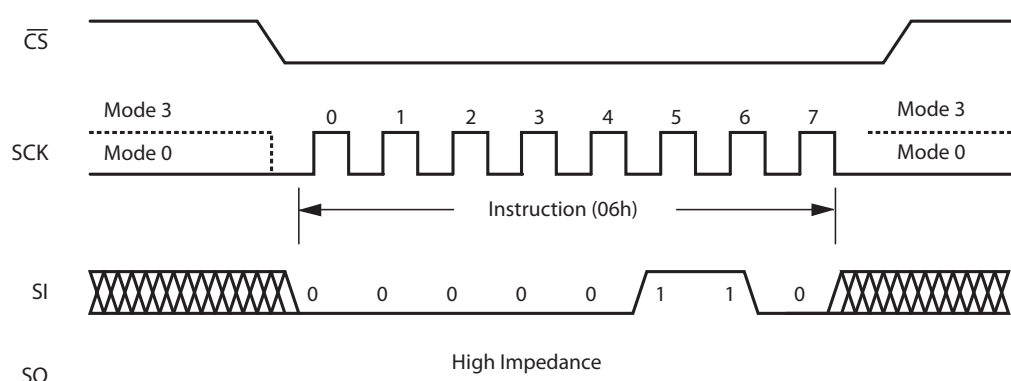
Figure 2.2 WREN**Write Disable (WRDI)**

The Write Disable (WRDI) command resets the WEL bit in the status register to 0. This prevents writes to status register or memory. The WRDI command is entered by driving \overline{CS} low, sending the command code, and then driving \overline{CS} high.

The WEL bit is reset to 0 on power-up or completion of WRDI.

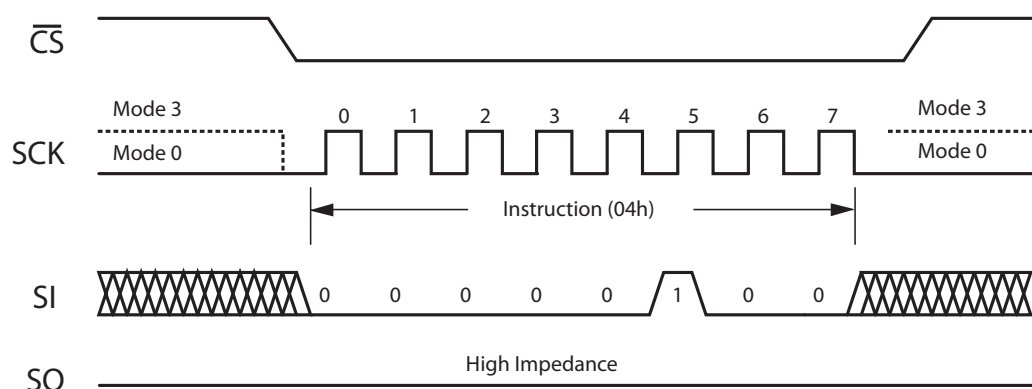
Figure 2.3 WRDI**Write Status Register (WRSR)**

The Write Status Register (WRSR) command allows new values to be written to the Status Register. The WRSR command is not executed unless the Write Enable Latch (WEL) has been set to 1 by executing a WREN command while pin \overline{WP} and bit SRWD correspond to values that make the status register writable as seen in table 2.4. Status Register bits are non-volatile with the exception of the WEL which is reset to 0 upon power cycling.

SPI COMMUNICATIONS PROTOCOL

The WRSR command is entered by driving \overline{CS} low, sending the command code and status register write data byte, and then driving \overline{CS} high. The WRSR command is entered by driving \overline{CS} low, sending the command code and status register write data byte, and then driving \overline{CS} high.

Figure 2.4 WRSR

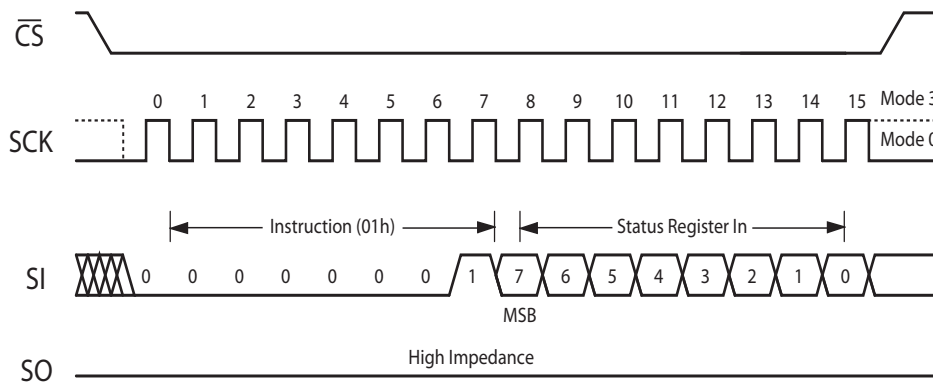

Read Data Bytes (READ)

The Read Data Bytes (READ) command allows data bytes to be read starting at an address specified by the 24-bit address. Only address bits 0-16 are decoded by the memory. The data bytes are read out sequentially from memory until the read operation is terminated by bringing \overline{CS} high. The entire memory can be read in a single command. The address counter will roll over to 0000h when the address reaches the top of memory.

The READ command is entered by driving \overline{CS} low and sending the command code. The memory drives the read data bytes on the SO pin. Reads continue as long as the memory is clocked. The command is terminated by bring \overline{CS} high.

Figure 2.5 READ

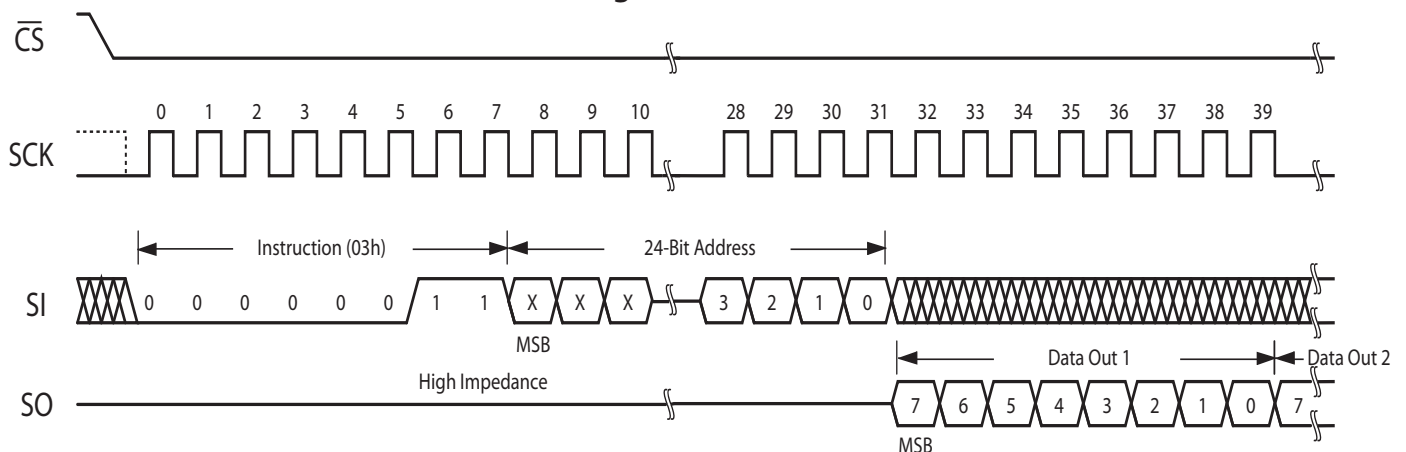

SPI COMMUNICATIONS PROTOCOL

Write Data Bytes (WRITE)

The Write Data Bytes (WRITE) command allows data bytes to be written starting at an address specified by the 24-bit address. Only address bits 0-16 are decoded by the memory. The data bytes are written sequentially in memory until the write operation is terminated by bringing \overline{CS} high. The entire memory can be written in a single command. The address counter will roll over to 0000h when the address reaches the top of memory.

Unlike EEPROM or Flash Memory, MRAM can write data bytes continuously at its maximum rated clock speed without write delays or data polling. Back to back WRITE commands to any random location in memory can be executed without write delay. MRAM is a random access memory rather than a page, sector, or block organized memory so it is ideal for both program and data storage.

The WRITE command is entered by driving \overline{CS} low, sending the command code, and then sequential write data bytes. Writes continue as long as the memory is clocked. The command is terminated by bringing \overline{CS} high.

Figure 2.6 WRITE

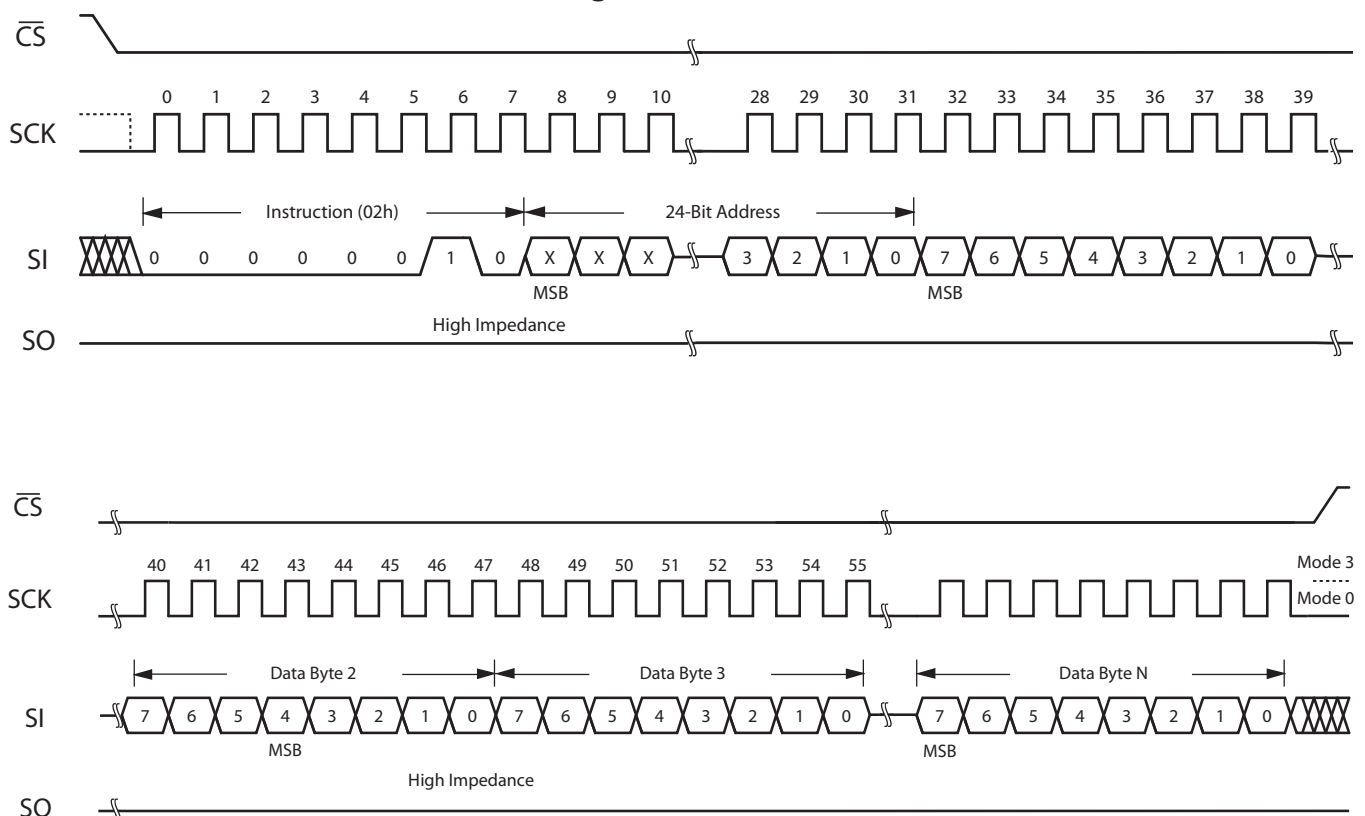

SPI COMMUNICATIONS PROTOCOL

Enter Sleep Mode (SLEEP)

The Enter Sleep Mode (SLEEP) command turns off all MRAM power regulators in order to reduce the overall chip standby power to 3 μA typical. The SLEEP command is entered by driving $\overline{\text{CS}}$ low, sending the command code, and then driving $\overline{\text{CS}}$ high. The standby current is achieved after time, t_{DP} .

Figure 2.7 SLEEP

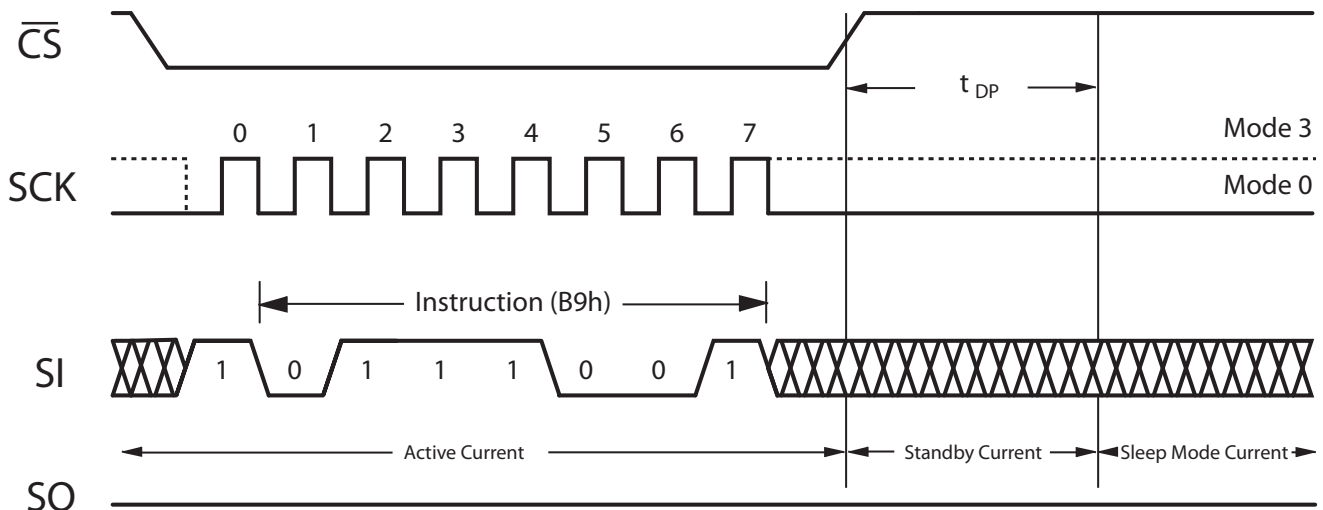

Exit Sleep Mode (WAKE)

The Exit Sleep Mode (WAKE) command turns on internal MRAM power regulators to allow normal operation. The WAKE command is entered by driving $\overline{\text{CS}}$ low, sending the command code, and then driving $\overline{\text{CS}}$ high. The memory returns to standby mode after t_{RDP} . The $\overline{\text{CS}}$ pin must remain high until the t_{RDP} period is over.

Figure 2.8 WAKE

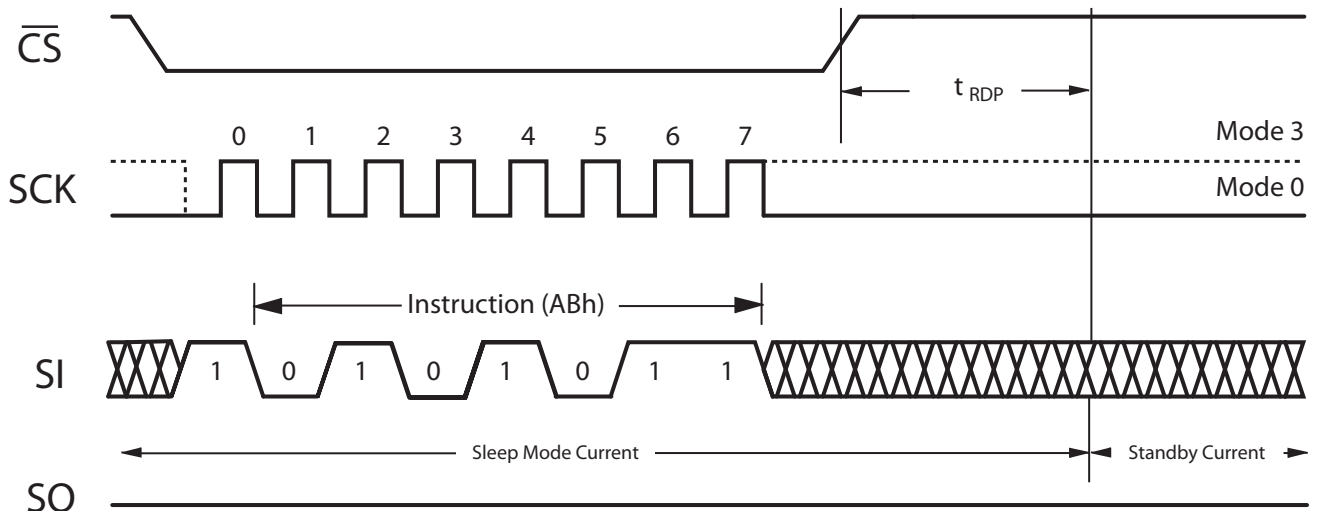

3. ELECTRICAL SPECIFICATIONS

Absolute Maximum Ratings

This device contains circuitry to protect the inputs against damage caused by high static voltages or electric fields; however, it is advised that normal precautions be taken to avoid application of any voltage greater than maximum rated voltages to these high-impedance (Hi-Z) circuits.

The device also contains protection against external magnetic fields. Precautions should be taken to avoid application of any magnetic field more intense than the field intensity specified in the maximum ratings.

Table 3.1 Absolute Maximum Ratings¹

Symbol	Parameter	Conditions	Limit	Unit
V_{DD}	Supply voltage ²		-0.5 to 4.0	V
V_{IN}	Voltage on any pin ²		-0.5 to $V_{DD} + 0.5$	V
I_{OUT}	Output current per pin		± 20	mA
P_D	Package power dissipation ³		0.600	W
T_{BIAS}	Temperature under bias	Industrial	-45 to 95	°C
		AEC-Q100 Grade 1	-45 to 130	°C
T_{stg}	Storage Temperature		-55 to 150	°C
T_{Lead}	Lead temperature	3 minutes max	260	°C
H_{max_write}	Maximum magnetic field exposure	Write	12,000	A/m
H_{max_read}	Maximum magnetic field exposure	Read or Standby		

¹ Permanent device damage may occur if absolute maximum ratings are exceeded. Functional operation should be restricted to recommended operating conditions. Exposure to excessive voltages or magnetic fields could affect device reliability.

² All voltages are referenced to V_{SS} . The DC value of V_{IN} must not exceed actual applied V_{DD} by more than 0.5V. The AC value of V_{IN} must not exceed applied V_{DD} by more than 2V for 10ns with I_{IN} limited to less than 20mA.

³ Power dissipation capability depends on package characteristics and use environment.

ELECTRICAL SPECIFICATIONS

Table 3.2 Operating Conditions

Symbol	Parameter	Grade	Min	Max	Unit
V_{DD}	Power supply voltage	Industrial	2.7	3.6	V
		AEC-Q100 Grade1	3.0	3.6	V
V_{IH}	Input high voltage	All	2.2	$V_{DD} + 0.3$	V
V_{IL}	Input low voltage	All	-0.5	0.8	V
T_A	Temperature under bias	Industrial	-40	85	°C
		AEC-Q100 Grade1 ¹	-40	125	°C

¹ AEC-Q100 Grade 1 temperature profile assumes 10 percent duty cycle at maximum temperature (2 years out of 20-year life.)

Table 3.3 DC Characteristics

Symbol	Parameter	Conditions	Min	Typical	Max	Unit
I_{LI}	Input leakage current		-	-	± 1	μA
I_{LO}	Output leakage current		-	-	± 1	μA
V_{OL}	Output low voltage	$I_{OL} = +4 \text{ mA}$	-	-	0.4	V
		$I_{OL} = +100 \mu A$	-	-	$V_{SS} + 0.2v$	V
V_{OH}	Output high voltage	$(I_{OH} = -4 \text{ mA})$	2.4	-	-	V
		$(I_{OH} = -100 \mu A)$	$V_{DD} - 0.2$	-	-	V

Table 3.4 Power Supply Characteristics

Symbol	Parameter	Conditions	Typical	Max	Unit
I_{DDR}	Active Read Current	1 MHz	2.5	3	mA
		40 MHz	6	10	mA
I_{DDW}	Active Write Current	1 MHz	8	13	mA
		40 MHz	23	27	mA
I_{SB}	Standby Current	\overline{CS} high and SPI bus inactive	90	115	μA
I_{ZZ}	Standby Sleep Mode Current	\overline{CS} high and SPI bus inactive	7	30	μA

4. TIMING SPECIFICATIONS

Table 4.1 Capacitance¹

Symbol	Parameter	Typical	Max	Unit
C_{in}	Control input capacitance	-	6	pF
$C_{I/O}$	Input/Output capacitance	-	8	pF

¹ $f = 1.0$ MHz, $dV = 3.0$ V, $T_A = 25$ °C, periodically sampled rather than 100% tested.

Table 4.2 AC Measurement Conditions

Parameter	Value	Unit
Logic input timing measurement reference level	1.5	V
Logic output timing measurement reference level	1.5	V
Logic input pulse levels	0 or 3.0	V
Input rise/fall time	2	ns
Output load for low and high impedance parameters	See Figure 4.1	
Output load for all other timing parameters	See Figure 4.2	

Figure 4.1 Output Load for Impedance Parameter Measurements

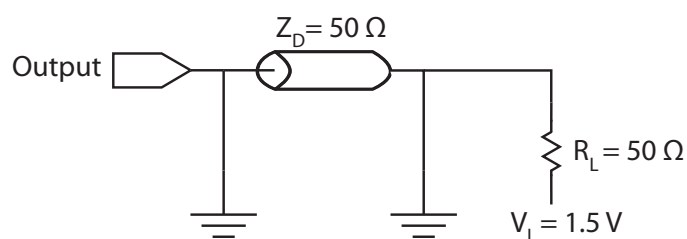
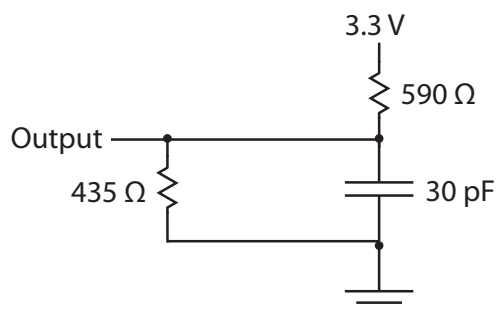

Figure 4.2 Output Load for all Other Parameter Measurements



TIMING SPECIFICATIONS

Power-Up Timing

The MR25H10 is not accessible for a start-up time, $t_{PU} = 400 \mu s$ after power up. Users must wait this time from the time when $V_{DD}(\min)$ is reached until the first \overline{CS} low to allow internal voltage references to become stable. The \overline{CS} signal should be pulled up to V_{DD} so that the signal tracks the power supply during power-up sequence.

Table 4.3 Power-Up

Symbol	Parameter	Min	Typical	Max	Unit
V_{WI}	Write Inhibit Voltage	2.2	-	2.7	V
t_{PU}	Startup Time	400	-	-	μs

Figure 4.3 Power-Up Timing

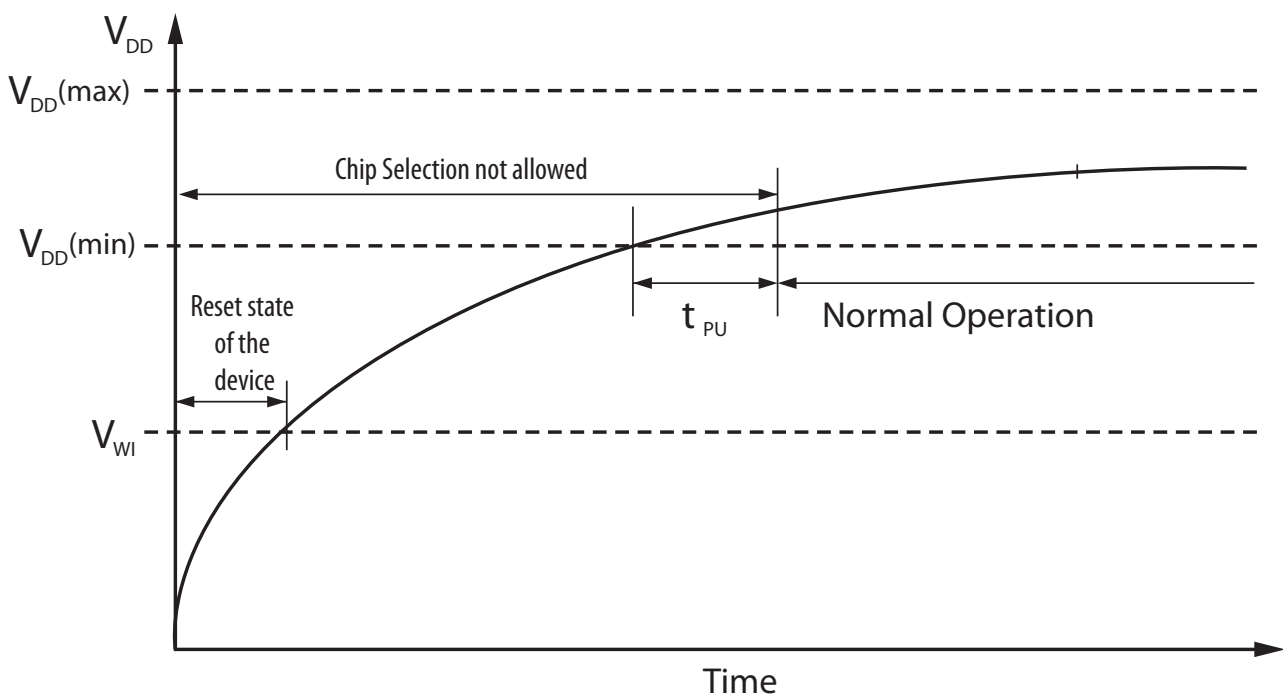

TIMING SPECIFICATIONS

Synchronous Data Timing

Table 4.4 AC Timing Parameters¹

Symbol	Parameter	Conditions	Min	Max	Unit
f_{SCK}	SCK Clock Frequency		0	40	MHz
t_{RI}	Input Rise Time		-	50	ns
t_{RF}	Input Fall Time		-	50	ns
t_{WH}	SCK High Time		11	-	ns
t_{WL}	SCK Low Time		11	-	ns
Synchronous Data Timing (See figure 4.4)					
t_{CS}	\overline{CS} High Time		40	-	ns
t_{CSS}	\overline{CS} Setup Time		10	-	ns
t_{CSH}	\overline{CS} Hold Time		10	-	ns
t_{SU}	Data In Setup Time		5	-	ns
t_H	Data In Hold Time		5	-	ns
t_V	Output Valid Industrial Grade	$V_{DD} = 2.7$ to $3.6V$.	0	10	ns
	Output Valid Industrial Grade	$V_{DD} = 3.0$ to $3.6V$.	0	9	ns
	Output Valid AEC-Q100 Grade 1	$V_{DD} = 3.0$ to $3.6V$.	0	10	ns
t_{HO}	Output Hold Time		0	-	ns
HOLD Timing (See figure 4.5)					
t_{HD}	\overline{HOLD} Setup Time		10	-	ns
t_{CD}	\overline{HOLD} Hold Time		10	-	ns
t_{LZ}	\overline{HOLD} to Output Low Impedance		-	20	ns
t_{HZ}	\overline{HOLD} to Output High Impedance		-	20	ns
Other Timing Specifications					
t_{WPS}	\overline{WP} Setup To \overline{CS} Low		5	-	ns
t_{WPH}	\overline{WP} Hold From \overline{CS} High		5	-	ns
t_{DP}	Sleep Mode Entry Time		3	-	μs
t_{RDP}	Sleep Mode Exit Time		400	-	μs
t_{DIS}	Output Disable Time		12	-	ns

¹ Over the Operating Temperature Range and $C_L = 30$ pF

Figure 4.4 Synchronous Data Timing

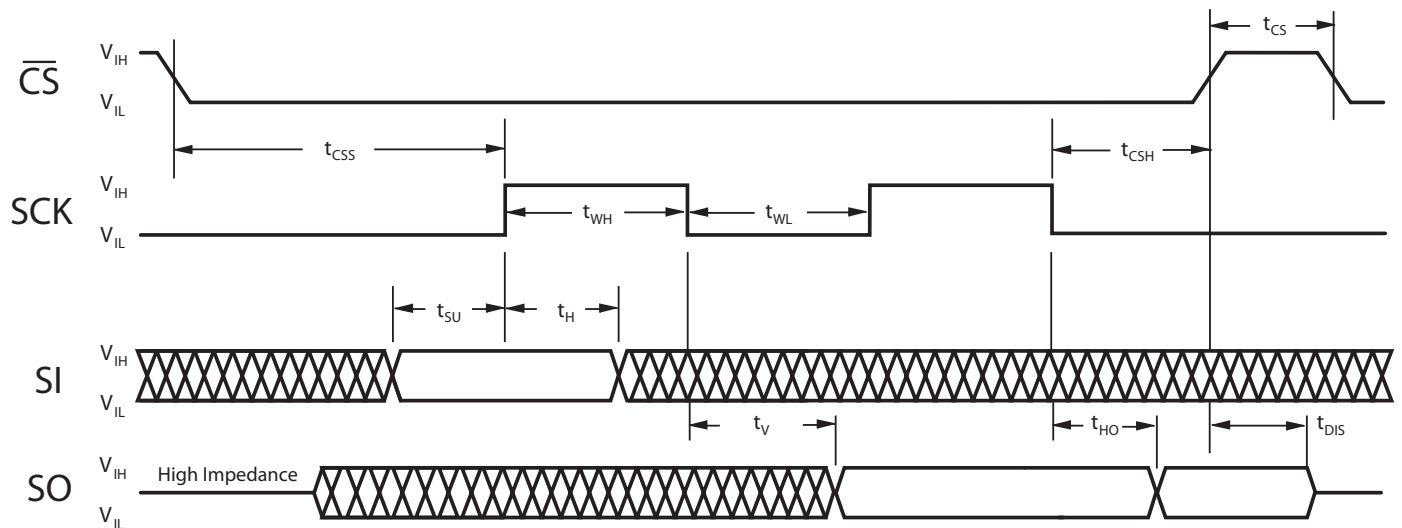
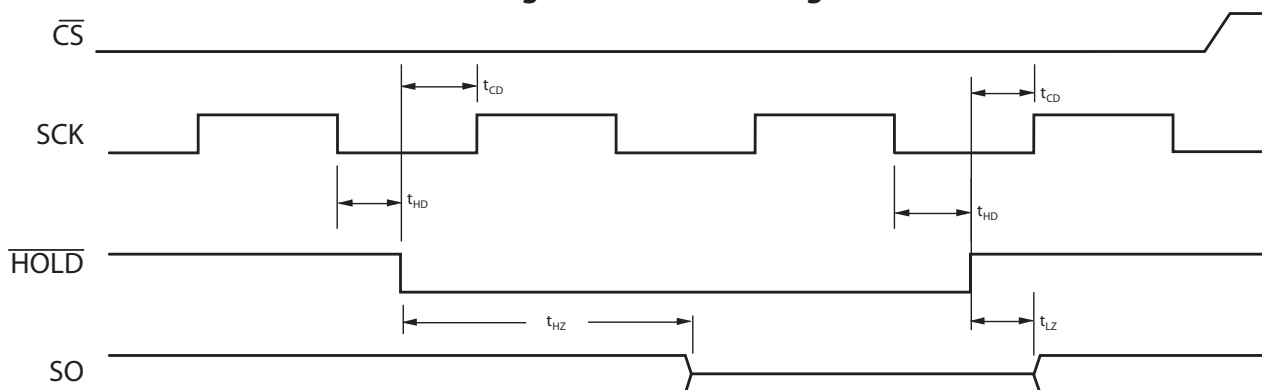

Figure 4.5 HOLD Timing



5. ORDERING INFORMATION

Figure 5.1 Part Numbering System

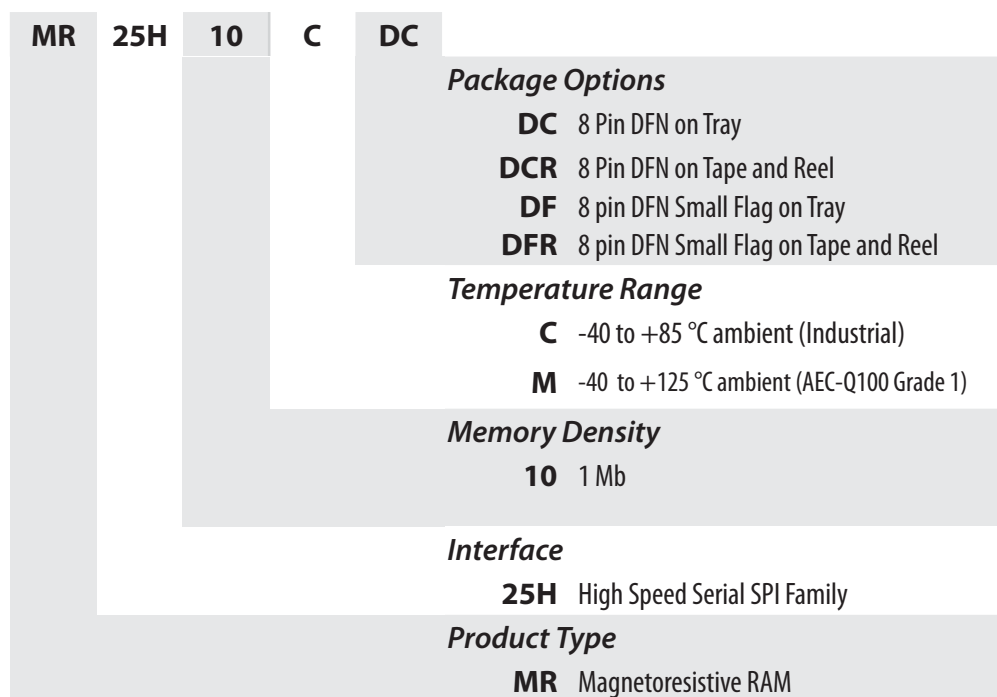

Table 5.1 Available Parts

Grade	Temperature Range	Package	Shipping Container	Order Part Number
Industrial	-40 to +85 C	8-DFN	Tray	MR25H10CDC
			Tape and Reel	MR25H10CDCR
		Small Flag 8-DFN	Tray	MR25H10CDF
			Tape and Reel	MR25H10CDFR
AEC-Q100 Grade 1	-40 to +125 C	8-DFN	Tray	MR25H10MDC
			Tape and Reel	MR25H10MDCR
		Small Flag 8-DFN	Tray	MR25H10MDF
			Tape and Reel	MR25H10MDFR

6. MECHANICAL DRAWINGS



Figure 6.1 DFN Package

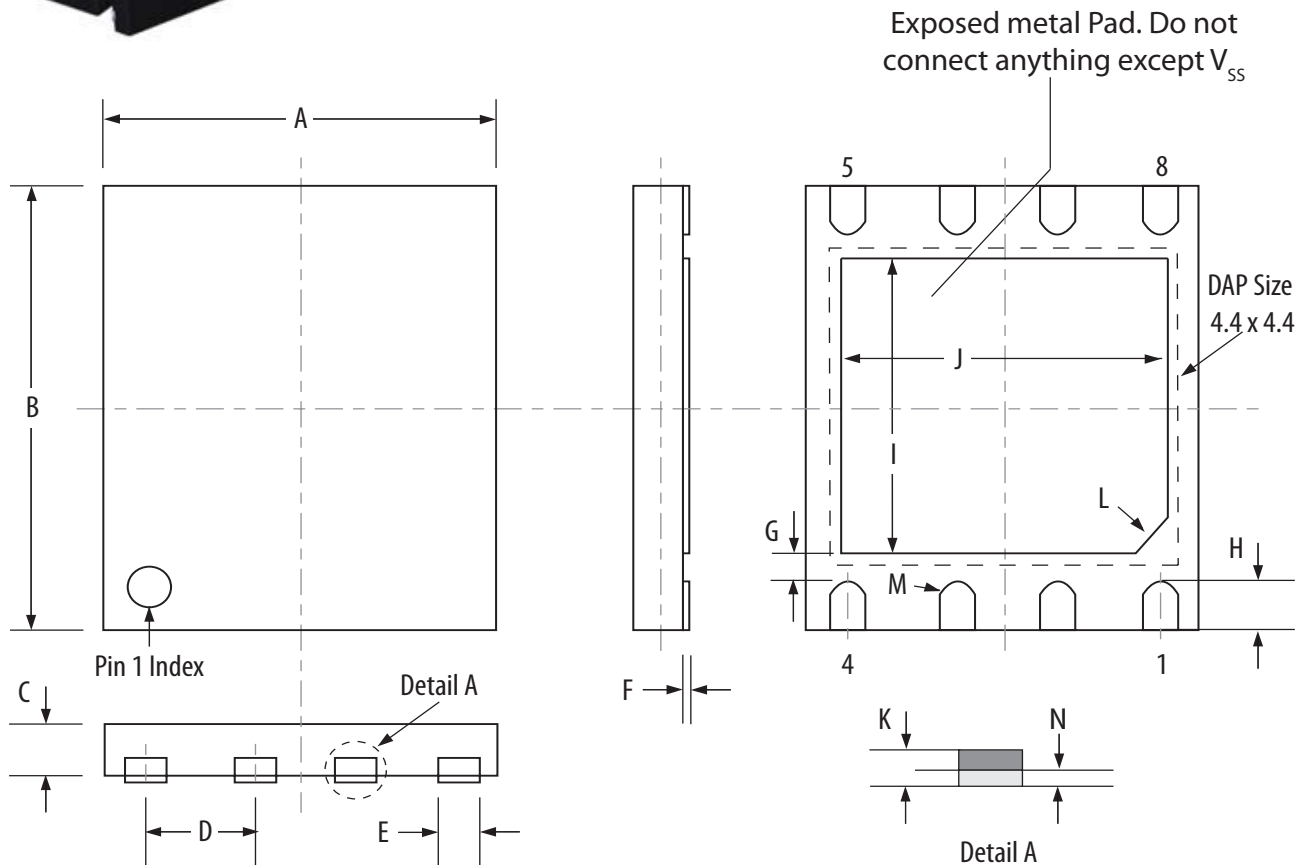

Dimension	A	B	C	D	E	F	G	H	I	J	K	L	M	N
Max.	5.10	6.10	1.00	1.27	0.45	0.05	0.35	0.70	4.20	4.20	0.261	C0.35	R0.20	0.05
Min.	4.90	5.90	0.90	BSC	0.35	0.00	Ref.	0.50	4.00	4.00	0.195			0.00

NOTE:

1. All dimensions are in mm. Angles in degrees.
2. Coplanarity applies to the exposed pad as well as the terminals. Coplanarity shall be within 0.08 mm.
3. Warpage shall not exceed 0.10 mm.
4. Refer to JEDEC MO-229

6. MECHANICAL DRAWINGS



Figure 6.2 Small Flag DFN Package

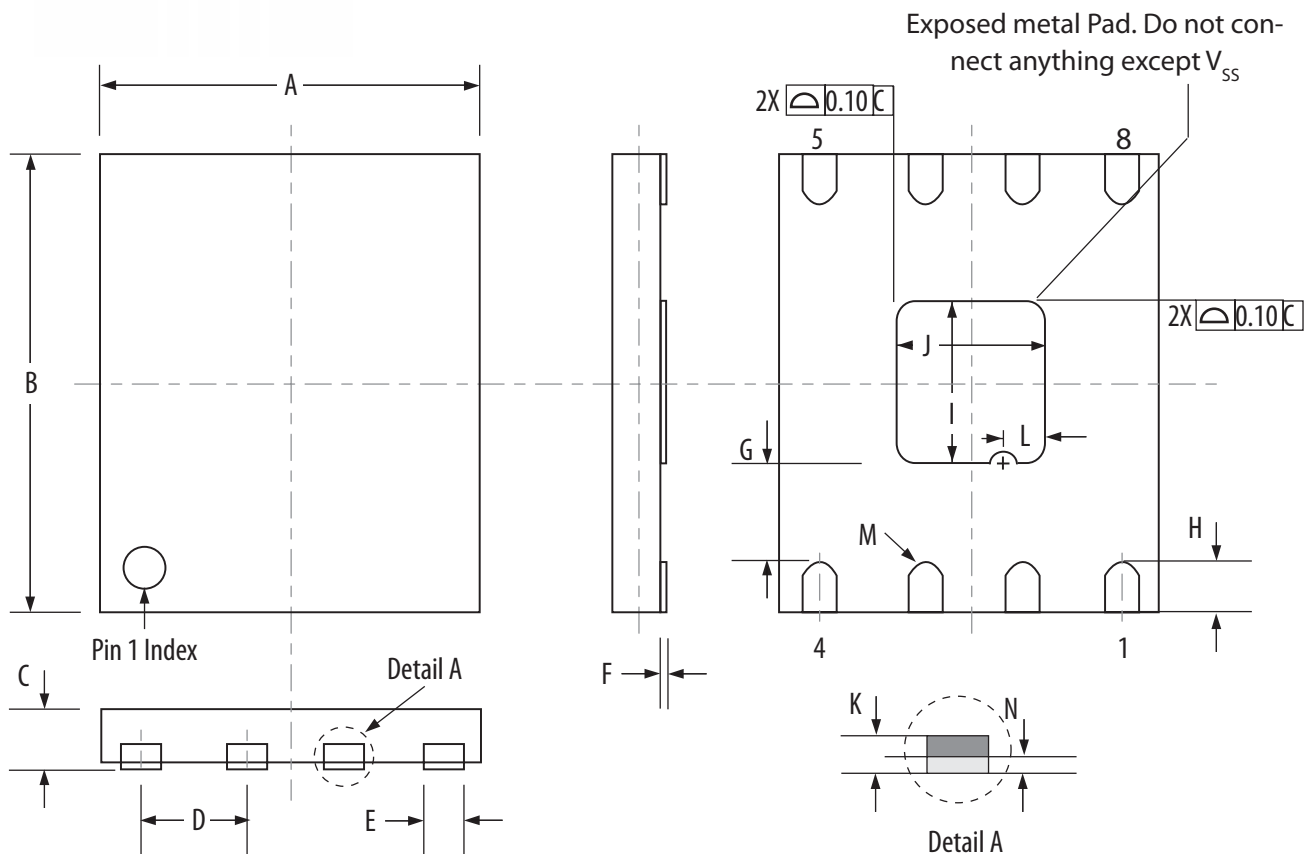

Dimension	A	B	C	D	E	F	G	H	I	J	K	L	M	N
Max	5.10	6.10	0.90	1.27	0.45	0.05	1.60	0.70	2.10	2.10	.210	C0.45	R0.20	0.05
Min	4.90	5.90	0.80	BSC	0.35	0.00	1.20	0.50	1.90	1.90	.196			0.00

NOTE:

1. All dimensions are in mm. Angles in degrees.
2. Coplanarity applies to the exposed pad as well as the terminals. Coplanarity shall be within 0.08 mm.
3. Warpage shall not exceed 0.10 mm.
4. Refer to JEDEC MO-229

7. REVISION HISTORY

Revision	Date	Description of Change
0	Sep 12, 2008	Initial Advance Information Release
1	Jul 10, 2009	Change ac load resistance, tPU to 400 us, tRDP to 400 us, Change # of Address Bytes in Table 2 to 3, New Package Drawing, Make Preliminary
2	Jul 16, 2009	Increase Absolute Max Magnetic Field during write, read, and standby to 12,000 A/m
3	Jan 5, 2010	Described block protect in detail with power sequencing.
4	Feb 5, 2010	Added section system configuration.
5	May 17, 2010	Removed commercial specifications. All parts meet industrial specifications.
6	Sep 14, 2011	Corrected various typos. Clarified block and status register protection description. Revised Table 3.4 Power Supply specifications. Added AEC-Q100 Grade 1 ordering option. Revised Table 3.1, Table 3.2, Table 4.4 revised and Note 2 deleted, revised Figure 5.1 and Table 5.1.
7	November 18, 2011	Corrected V_{OL} in Table 3.3 to read $V_{OL} \text{ Max} = V_{SS} + 0.2v$. Operating Conditions Power Supply Voltage for AEC-Q100 Grade1 revised to 3.0-3.6v. Table 4.4: Output Valid t_v specifications revised to include V_{DD} ranges for Industrial and AEC-Q100 Grade 1 options. Corrected SI waveform in Figure 2.8. Output Valid, t_v for AEC-Q100 Grade revised from 9ns max to 10ns max in Table 4.4. New Small Flag DFN package option added to Page 1 Features and available parts Table 5.1. DFN Small Flag drawing and dimensions table added as Figure 6.2. Figure 6.1, DFN Package, cleaned up with better quality drawing and dimension table. No specifications were changed in Figure 6.1.
8	October 19, 2012	Reformatted tables for Section 3 Electrical Characteristics and timing parameters, Table 4.4. Revised Ordering Part Numbers Table 5.1. Removed MDF and MDFR options. MDC and MDCR options are now qualified. Added Small Flag DFN illustrations. Revised 8-DFN package drawing to show correct proportion for flag and package. Corrected errors in DFN package outline drawings. Corrected V_{DD} range for AEC-Q100 Ψ specification.
9	April 17, 2013	Added Automotive Grade AEC-Q100 Grade 1 for Small Flag DFN package.