

isc Silicon NPN Power Transistor

2SC3834

DESCRIPTION

- Low Collector Saturation Voltage  
:  $V_{CE(sat)} = 0.5V(\text{Max}) @ I_C = 3A$
- Collector-Emitter Breakdown Voltage-  
:  $V_{(BR)CEO} = 120V (\text{Min})$
- Good Linearity of  $h_{FE}$
- Minimum Lot-to-Lot variations for robust device performance and reliable operation.

APPLICATIONS

- Designed for use in humidifier , DC/DC converter and general purpose applications

ABSOLUTE MAXIMUM RATINGS( $T_a=25^\circ\text{C}$ )

SYMBOL	PARAMETER	VALUE	UNIT
$V_{CBO}$	Collector-Base Voltage	200	V
$V_{CEO}$	Collector-Emitter Voltage	120	V
$V_{EBO}$	Emitter-Base Voltage	8	V
$I_C$	Collector Current-Continuous	7	A
$I_{CM}$	Collector Current-Pulse	14	A
$I_B$	Base Current-Continuous	3	A
$P_C$	Collector Power Dissipation @ $T_C=25^\circ\text{C}$	50	W
$T_J$	Junction Temperature	150	$^\circ\text{C}$
$T_{stg}$	Storage Temperature Range	-55~150	$^\circ\text{C}$

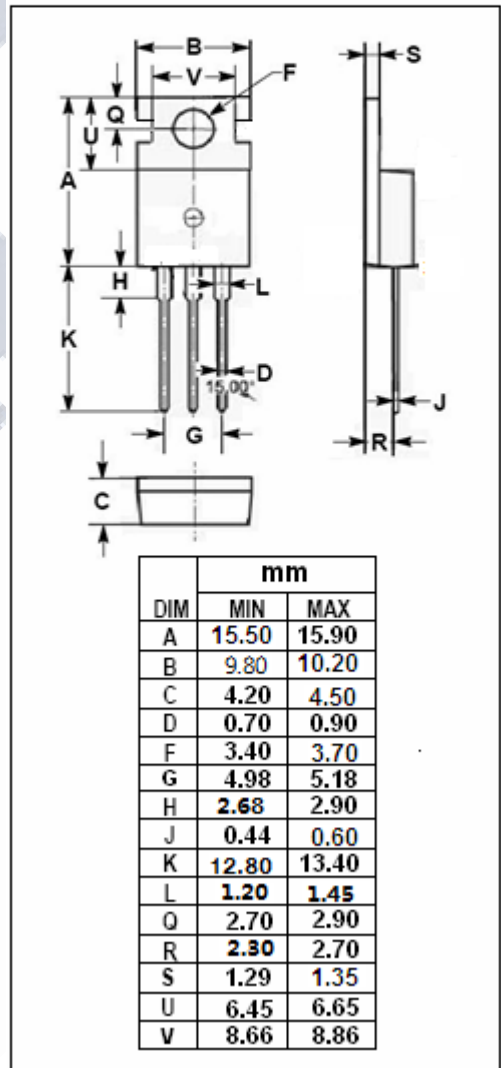
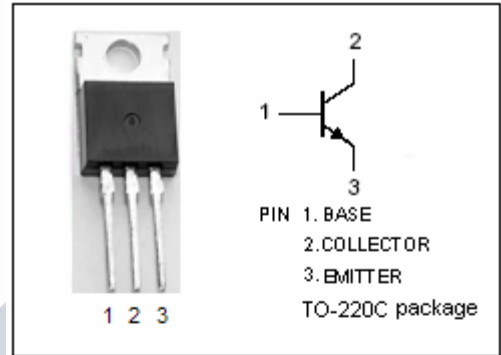

## isc Silicon NPN Power Transistor

2SC3834

## ELECTRICAL CHARACTERISTICS

 $T_C=25^{\circ}\text{C}$  unless otherwise specified

SYMBOL	PARAMETER	CONDITIONS	MIN	TYP.	MAX	UNIT
$V_{(BR)CEO}$	Collector-Emitter Breakdown Voltage	$I_C=50\text{mA}; I_B=0$	120			V
$V_{CE(sat)}$	Collector-Emitter Saturation Voltage	$I_C=3\text{A}; I_B=0.3\text{A}$			0.5	V
$V_{BE(sat)}$	Base-Emitter Saturation Voltage	$I_C=3\text{A}; I_B=0.3\text{A}$			1.2	V
$I_{CBO}$	Collector Cutoff Current	$V_{CB}=200\text{V}; I_E=0$			100	$\mu\text{A}$
$I_{EBO}$	Emitter Cutoff Current	$V_{EB}=8\text{V}; I_C=0$			100	$\mu\text{A}$
$h_{FE}$	DC Current Gain	$I_C=3\text{A}; V_{CE}=4\text{V}$	70		220	
$f_T$	Current-Gain—Bandwidth Product	$I_E=0.5\text{A}; V_{CE}=12\text{V}$	20			MHz
$C_{OB}$	Output Capacitance	$I_E=0; V_{CB}=10\text{V}; f_{\text{test}}=1.0\text{MHz}$		110		pF

## Switching times

$t_{on}$	Turn-on Time	$I_C=3\text{A}; I_{B1}=0.3\text{A}; I_{B2}=-0.6\text{A}$ $R_L=16.7\Omega; V_{CC}=50\text{V}$			0.5	$\mu\text{s}$
$t_{stg}$	Storage Time				3.0	$\mu\text{s}$
$t_f$	Fall Time				0.5	$\mu\text{s}$

◆  $h_{FE}$  Classifications

O	Y	G
70-120	100-200	160-220