

IN-600

*Online visual automatic
dividing machine*
在线视觉自动分板机



IN-600

Online visual automatic dividing machine

在线视觉自动分板机

➤ 瑞盛 (RASEM) IN-600是一款人性化智能化, 不需要人工干预的全自动在线PCBA分板机; 配置高速高清CCD视觉对位补偿系统, 确保设备在高速、高精度下稳定运行; 自动换刀、断刀检测, 降低产线消耗品更换时间, 确保设备不间断生产; 采用洁净式吸尘系统, 提高PCBA清洁度; 选用NSK高速主轴, 分板应力小, 板边平整; 适合高产能、高精度、高要求的客户, 我们提供PCBA在线分板完整的解决方案。

➤ RASEM (IN-600) is a humanized and intelligent, automatic online PCBA sub board that does not need manual intervention; configuring high definition and high definition CCD visual counterposition system to ensure the stable operation of the equipment in high speed and high precision; automatic knife changing, cutting tool detection, reducing the replacement time of production line dissipation products and ensuring the continuous production of equipment. Using clean vacuum cleaning system to improve PCBA cleanliness; select NSK high speed spindle, small plate stress, flat edge; suitable for high productivity, high precision, high requirements of customers, we provide a complete solution of PCBA online sub board.

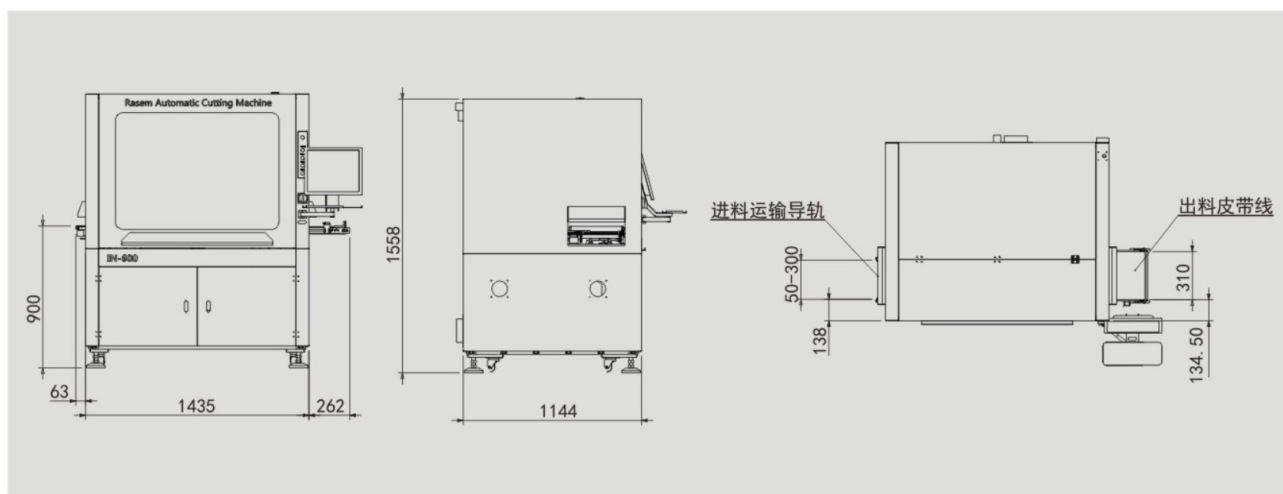

特点

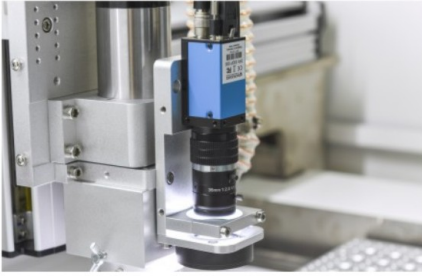

精湛的视觉系统 Superb visual system

由德国Imaging工业相机和日本Moritex镜头组成，高像素视觉，自动MRAK补偿提高编辑与切割精度
A precise machine visual system which consists of German imaging industrial camera, Japan Moritex lens, High pixel vision, automatic MRAK compensation improves editing and cutting accuracy



在线全自动化系统 Online full automation system

在线能达到全自动化最高生产效率，同时也能依照客户需求调整生产速度，并确保机台每个动作都可完整顺畅，为客户带来最大效益。

Online can achieve full automation of the highest production efficiency, but also can adjust the production speed according to customer needs, and ensure that each movement of the machine can be complete and smooth, to bring the maximum benefit to the customers.



铣刀智能系统 Intelligent system of milling cutter

1、根据PCB的厚度调整下刀深度，提高铣刀利用率，节省成本。
2、更换铣刀，无需重做或修改程序。

1. Adjust the depth of the cutter according to the thickness of the PCB, improve the milling cutter utilization rate and save the cost.
2. Change the milling cutter, no need to redo or modify the program.



自动换刀系统(选配) Automatic knife change system (selection)

标准刀具支持3.175mm规格刀具，配NSK精密换刀系统，当切割铣刀到达其设定切割寿命时，系统在最短时间内自动更换新铣刀并回复生产，大幅降低产线消耗品更换时间及人员的配置。

The standard tool library supports the 3.175mm specification tool and the NSK precision knife exchange system. When the cutting milling cutter reaches its set cutting life, the system automatically changes the new milling cutter in the shortest time and returns the production, greatly reducing the replacement time of the line consumption and the configuration of the personnel.



工业4.0-MES系统 Barcode / two-dimensional code scanning

1、服务器数据自动调取
2、上传机台数据及生产数据
3、实时监测设备状况
4、标配条码扫描,可实现分板后即时上传单板条码信息

1. The server data is automatically retrieved
2. Upload machine data and production data
3. Real-time monitoring of equipment status
4. Standard bar code scanning, can be achieved immediately after the board upload board bar code information

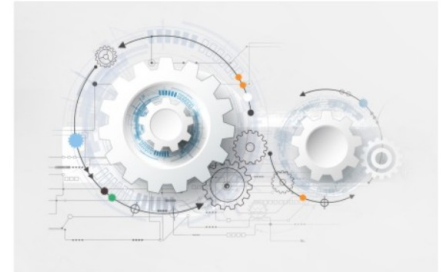

自诊断功能 Self diagnostic function

错误信息自行诊断，对机器在使用过程中的故障，可进行自行诊断，方便查找故障，快速处理问题，及时恢复生产。

The fault information can be diagnosed by itself, and the machine can diagnose itself in the course of its use. It is easy to find faults, deal with problems quickly, and resume production in time.

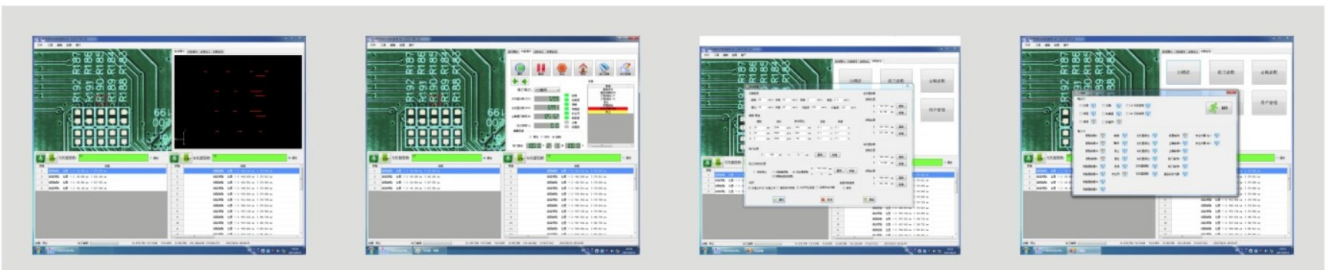

方便的操作系统 User Friendly operation system

采用Windows7中英文版操作界面，操作简单，维修方便

Full proprietary rights of the Windows7 Chinese & English operating system, simple operation, easy maintenance

规格参数

项目	规格
有效切割尺寸	300*300 mm
入料方式	軌道輸送
出料方式	軌道送輸送 or 分區輸送
移載方式	真空吸嘴吸附移載
流向	左→右 or 右→左
切割功能	直線、圓型及圓弧補間
加工檯面	双台面
機台重覆精度	±0.01mm
切割精度	±0.05mm
最高移動速度	XY 800mm/s、Z 350mm/s
最大移動行程	X:810 Y:370 Z:90mm
主軸轉速	MAX. 60000rpm (adj)
切割速度	1~100mm/s (adj)
操作界面	視窗操作界面
程式教導方式	彩色CCD影像直覺式教導輸入
程式備份	USB界面
控制方式	PC BASE精密控制系統
XYZ軸驅動方式	AC伺服馬達
適用銑刀尺寸	Ø0.8~3.0mm
主機電源規格	AC220V 50/60HZ 單相(1Ø)
切割主機尺寸	1580(W)x1200(D)x1550(H)mm
切割主機重量	1000kg

项目	规格
集塵機功率	3HP
集塵機尺寸	690(W)x650(D)x1710(H)mm
集塵機電源規格	AC220V/380V 50/60HZ 三相(3Ø)
集塵機重量	120kg
集塵方式	下集塵/上集塵(選用)
規格	(380v) /50Hz 3相
輸出功率	2.2KW/3HP
入口風量	78±2m ³ /min(上) 35±3m ³ /min(下)
入口風速	72m±2/ec(上) 32±2/ec(下)
入口靜壓	300mmAq
入口口徑	Ø 40mm(上) 150mm(下)
出口口徑	Ø 100mm(上) 200mm(下)
噪音	75±3Db
淨重	50kg(上) 120kg(下)
集塵機尺寸	600mmx470mmx730mm(上) 690mmx650mmx1710mm(下)
過濾布管材質	100%Polyester
最高真空度(mmH2O)	2350 mmH2O
電機防護等級	IP54

瑞盛（东莞）自控技术有限公司

地址：东莞市寮步镇松山湖大道刘屋巷工业区

Tel: 0769-83078837 / 82223345

Fax: 0769-82223345

E-mail: rasem@rasem.com.cn

Web: www.rasem.com.cn

Rasem (Dongguan) Automation Technology Co., Ltd

Add: LiuHu Lane Industrial Zone, Songshan Lake Road,

Liaobu Town, Dongguan City

Tel: 0769-83078837 / 82223345

Fax: 0769-82223345

E-mail: rasem@rasem.com.cn

Web: www.rasem.com.cn

规格如有变更，恕不另行通知 Specifications are subject to change without notice
特殊规格，欢迎另行定做 Special specifications, welcome to be customized



扫描官网, 了解更多

代理商 Agent:

