

超薄式干式单板电磁制动器 CDI0S6AA/CDI1S5AA/CDI2S5AA/CDI005AA/CDI010AA/CDI020AA

折叠机电磁制动器、拼板机电磁制动器、打包机电磁制动器、裱纸机电磁制动器、钉箱机电磁制动器、电磁制动器
糊盒机电磁制动器、拉链机电磁制动器、月饼包陷机电磁制动器，用于定位、停止

新型号 CDI0S6AB/CDI0S6AC/CDI2S5AE/CDI010AB/CDI020AB

旧型号 CD-I-0.6/CD-I-1.5/CD-I-2.5/CD-I-5/CD-I-10/CD-I-20

仟位总代理 13710967244 余彦泽 <http://www.chaintail.com.cn>

CDI Series

Flat Design

乾式單板超薄型電磁煞車器 Electromagnetic Power-Applied Friction Brake

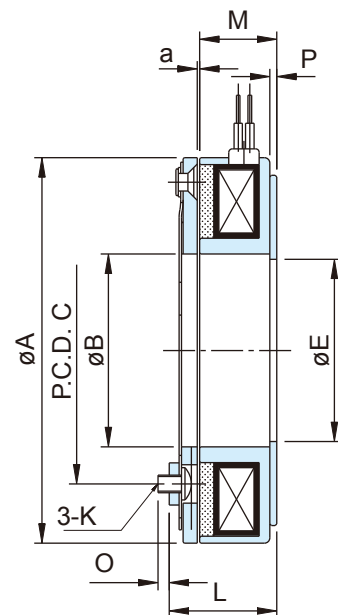
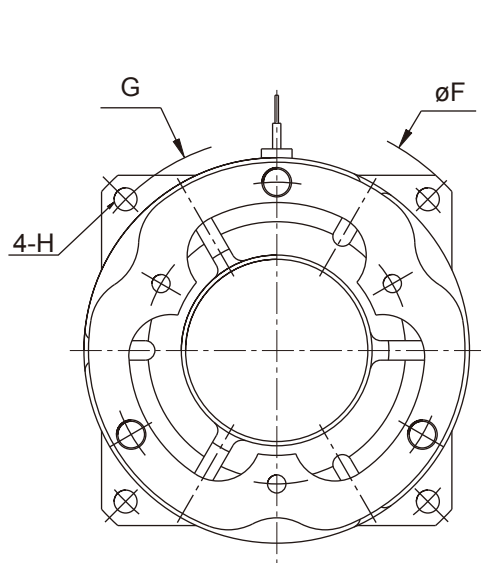

型號 MODEL	CDI0S6AA	CDI1S5AA	CDI2S5AA	CDI005AA	CDI010AA	CDI020AA	
靜摩擦轉距 Static Friction Torque [kgm](Nm)	0.55 (5.5)	1.1 (11)	2.2 (22)	4.5 (45)	9.0 (90)	17.5 (175)	
動摩擦轉距 Dynamic Friction Torque [kgm](Nm)	0.5 (5.0)	1.0 (10)	2.0 (20)	4.0 (40)	8.0 (80)	16 (160)	
功率 Power [24V](W) at 20°C	14	22	26	29	37	44	
徑 方 向 Radius	A	70	88	110	137	215	
	B	35	47	55	67	107	
	C	50	60	76	95	158	
	E	35	45	52	65	107	
	F	90	110	135	165	265	
	G	80	98	122	150	240	
	H	4.5	5.5	6.5	6.5	8.5	11
軸 方 向 Shaft	K	M3	M4	M5	M6	M10	
	L	25.2	27.75	29.9	36.7	47.4	
	M	19	20	21	26	31	
	O	5	6.15	8	11	17.5	
	P	2	2	2	2.5	3	3.2
	a	0.2 (±0.05)			0.3 (^{+0.05} / _{-0.1})		0.5 (⁻⁰ / _{-0.2})
重量 Weight (kg)	0.4	0.7	1.1	2.2	3.4	6.8	
保護素子 Protective device	07D470K			10D680K	14D680K		