

永磁式磁滯扭力控制器 CHT2S5AA/CHT005AA/CHT010AA/CHT030AA

仟岱总代理 13710967244 余彦泽 <http://www.chaintail.com.cn>

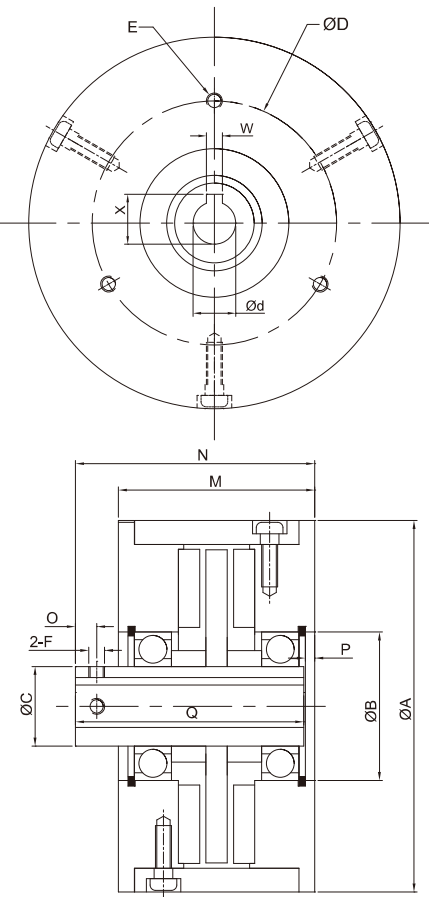

型號 Model		CHT2S5AA	CHT005AA	CHT010AA	CHT030AA
靜摩擦扭力 Static torque	Kgcm (Nm)	0.5~4.0 (0.05~0.40)	0.5~7.5 (0.05~0.75)	2~5 (0.2~1.5)	3~30 (0.3~3.0)
容許滑動功率 Heat Dissipation (W)		20	30	45	70
轉速 Speed (RPM) Max.		1800	1800	1800	1000
慣性矩 Inertia J*10 ⁻⁴ (kg*m ²)	本體 Flange	4.52	7.65	11.4	55.2
	軸心 Shaft	0.26	0.41	1.08	6.3
徑方向 Radial	A	60	70	82	118
	B	28	28	47	62
	C	12	15	25	35
	D	40	46	60	76.2
	E	M3*6L	M3*6L	M4*12L	M5*12L
	F	M3	M3	M4	M4
軸方向 Axial	M	35	37	50	55
	N	42	45	57	65
	O	3	4	4	6
	P	1.8	1.8	1.5	1.5
	Q	40	43	54	61
	鍵槽 Keyway	W	-	3	5
X		-	9.4	17.3	18.3
孔徑 Bore	d	6	8	15	16

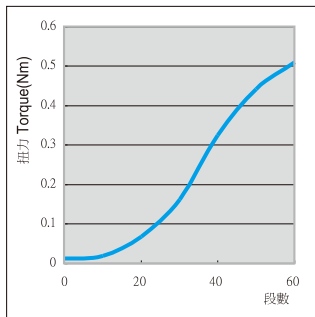

CHT2S5 Grade

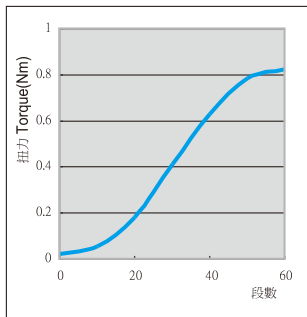

CHT005

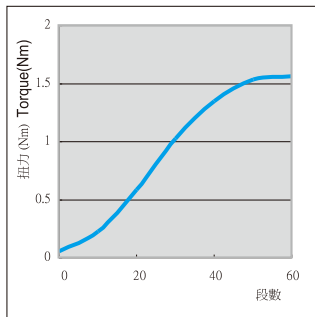

CHT010

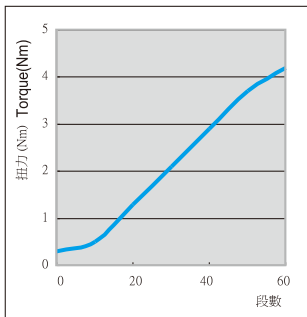

CHT030