

微型安全制动器、2.8 电机制动器、4.2 电机制动器 MHBS013AA/MHBS02AA/MHBS03AA/MHBS05AA/MHBS13AA
 MHB/MBS 安全制动器是用于当电力突然消失时，用来停止或保持负载。安全制动器是利用数条弹簧来供应制动力，
 为信赖性非常高的刹车。此种刹车典型应用于机械手臂、Z轴滚珠螺杆、伺服马达及一般电动马达的保持刹车。

仟岱总代理 13710967244 余彦泽 <http://www.chaintail.com.cn>

MHB Series

微型安全煞車器 Power-off Holding Brake - Miniature Type

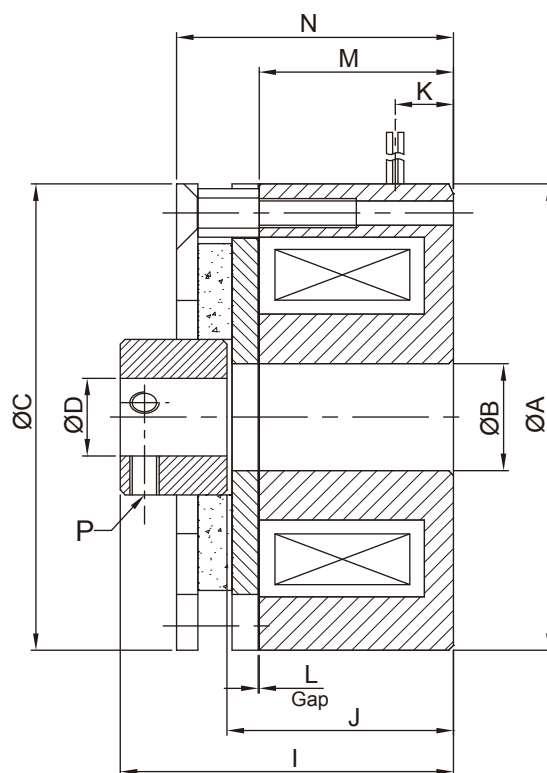
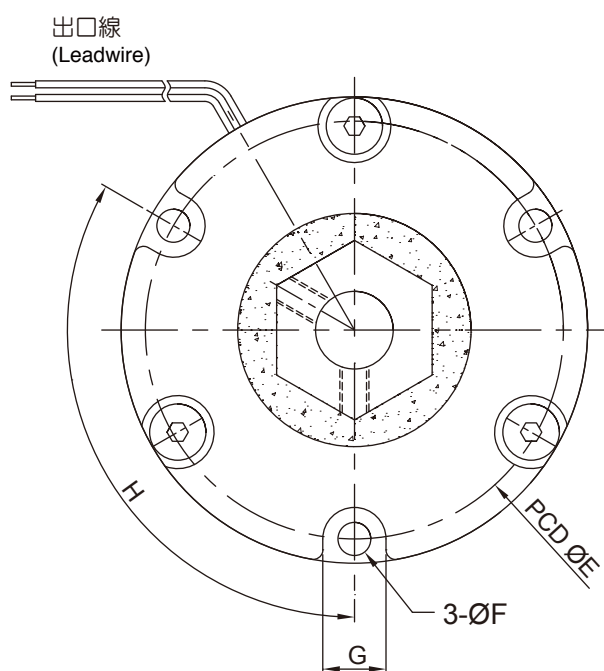

型號 MODEL	MHBS013AA	MHBS02AA	MHBS03AA	MHBS05AA	MHBS13AA	
靜摩擦轉距 Static Friction Torque [kgm](Nm)	0.012 (0.12)	0.02 (0.2)	0.03 (0.3)	0.05 (0.5)	0.13 (1.3)	
電壓 Voltage (VDC)	24					
功率 Power [24V](W) at 20°C	3.84	4.2	6	6.5	8.6	
外型尺寸 Exterior dimensions	A	34.9	40	34.9	48	56
	B	7.22	9	7.22	11	15
	C	37.5	40	37.5	48	56
	D	4	6	6	8	8
	E	30	35	30	43	50
	F	3.2	3	3.2	3.4	3.5
	G	6	6	6	6.5	7
	H	120				
	I	22.4	32	27.75	34.3	-
	J	13.9	21	19.75	23.3	21.25
	K	7	6.5	6	6	13.3
	L	0.08~0.12	0.1~0.15	0.08~0.12	0.1~0.15	0.08~0.13
	M	11.7	18	17.7	20	17.8
	N	17.65	26.2	23.7	28.5	28.5
P	2-M3					

註：部分型號軸套外型為四角型。

Part of models are designed with square hubs.