

电磁制动器带铝座可同轴安装 CG10S6AA/CG11S5AA/CG12S5AA/CG1005AA/CG1010AA/CG1020AA/CG1040AA

折叠机电磁制动器、拼板机电磁制动器、打包机电磁制动器、裱纸机电磁制动器、钉箱机电磁制动器、电磁制动器
糊盒机电磁制动器、拉链机电磁制动器、月饼包陷机电磁制动器，用于定位、停止

新型号 CDG0S6AK/CDG1S5AF/CDG2S5AD/CDG005AD/CDG010AE/CDG020AC/CDG040AB

旧型号 CD-G1-0.6/CD-G1-1.5/CD-G1-2.5/CD-G1-5/CD-G1-10/CD-G1-20/CD-G1-40

仟岱总代理 13710967244 余彦泽 <http://www.chaintail.com.cn>

乾式單板電磁煞車器 Electromagnetic Power-Applied Friction Brake - Flange Mounted

CG1 Series

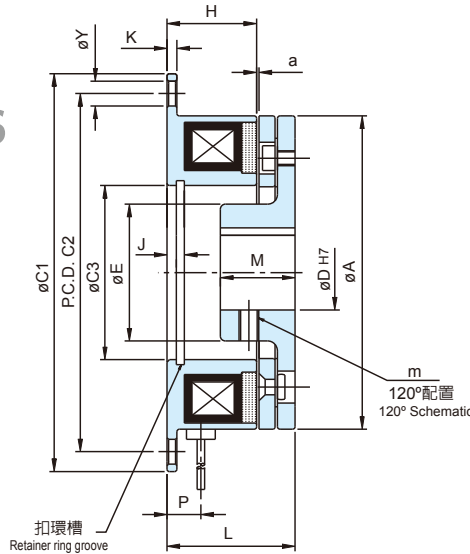

附導座 with short hub

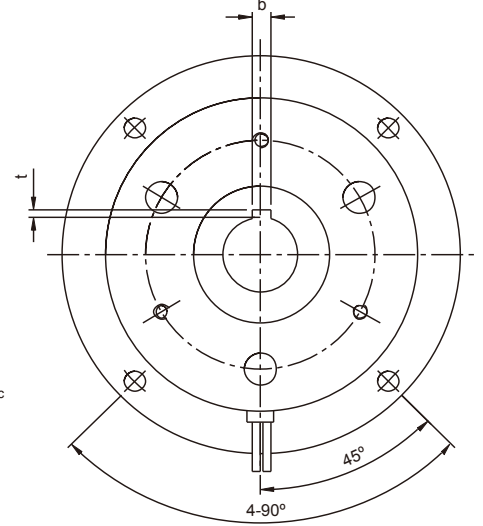

型號 MODEL		CG10S6AA(AB)	CG11S5AA(AB)	CG12S5AA(AB)	CG1005AA(AB)	CG1010AA(AB)	CG1020AA(AB)	CG1040AA(AB)
靜摩擦轉距 [kgm](Nm) Static Friction Torque		0.55 (5.5)	1.1 (11)	2.2 (22)	4.5 (45)	9 (90)	17.5 (175)	35 (350)
動摩擦轉距 [kgm](Nm) Dynamic Friction Torque		0.5 (5.0)	1.0 (10)	2.0 (20)	4.0 (40)	8 (80)	16 (160)	32 (320)
功率 Power [24V](W) at 20°C		11	15	20	25	35	45	60
徑 方 向 Radius	A	63	80	100	125	160	200	250
	C1	80	100	125	150	190	230	290
	C2	72	90	112	137	175	215	270
	C3	35	42	52	62	80	100	125
	D	15 (12)	20 (15)	25 (20)	30 (25)	40 (30)	50 (40)	60 (50)
	E	27.5	31	41	49	65	83	105
軸 方 向 Shaft	H	18	20	22	24	26	30	35.1
	J	3.5	4.3	5	5.5	6	7	8
	K	2	2.5	3	3.5	4	5	6
	L	25.55	28.8	32.9	37.3	42.5	50.5	59.6
	M	15	20	25	30	38	45	54
	P	7.5	9.5	8.9	9	11.5	9.5	15.5
	Y	5	6	7	7	9.5	9.5	11.5
	m	2-M4	2-M5		2-M6	2-M8		2-M10
	a	0.2 (±0.05)			0.3 (^{+0.05} / _{-0.1})		0.5 (⁰ / _{-0.2})	
	b	5 (4)	5 (5)	7 (5)	7 (7)	10 (7)	12 (10)	15 (12)
t	2.3 (1.8)	2.3 (2.3)	3.3 (2.3)	3.3 (3.3)	3.8 (3.3)	3.8 (3.8)	5.3 (3.8)	
重量 Weight (kg)		0.32	0.58	1.07	1.97	3.45	7.1	12.2
保護素子 Protective device		07D470K			10D680K	14D680K		20D680K