

16V/1A Fully Integrated Linear Charger for 1 Cell Li-ion Battery

DESCRIPTION

ETA4054 is a single cell, fully integrated constant current (CC)/constant voltage (CV) Li-ion battery charger. Its compact package with minimum external components requirement makes the ETA4054 ideal for portable applications. No external sense resistor or blocking diode is necessary for the ETA4054. Build-in thermal feedback mechanism regulates the charge current to control the die temperature during high power operation or at elevated ambient temperature. The ETA4054 has a pre-charge function for trickle charging deeply discharged batteries. The fast charge current can be programmed by an external resistor. CV regulation mode is automatically enabled once the battery's charging curve reaches the constant voltage portion. The output current then decays and is finally terminated once the charge current drops to 1/10th of the programmed value. The ETA4054 keeps monitoring the battery voltage and enables a new charge cycle once the voltage drops by 150mV below the CV value.

ETA4054 is in a tiny SOT23-5 package.

FEATURES

- ◆ 16V standoff input voltage at VIN and BAT pins
- ◆ 4.2V charge termination voltage
- ◆ Charge current up to 750mA in SOT23-5 package
- ◆ No damage when battery reversely connected
- ◆ 25uA supply current when standby
- ◆ Soft-start limits in-rush current
- ◆ SOT23-5 Package

APPLICATIONS

- ◆ Toys
- ◆ Bluetooth applications
- ◆ Li-ion battery powered devices

ORDERING INFORMATION

PART	PACKAGE PIN	TOP MARK
ETA4054S2F	SOT23-5	BIYW

TYPICAL APPLICATION

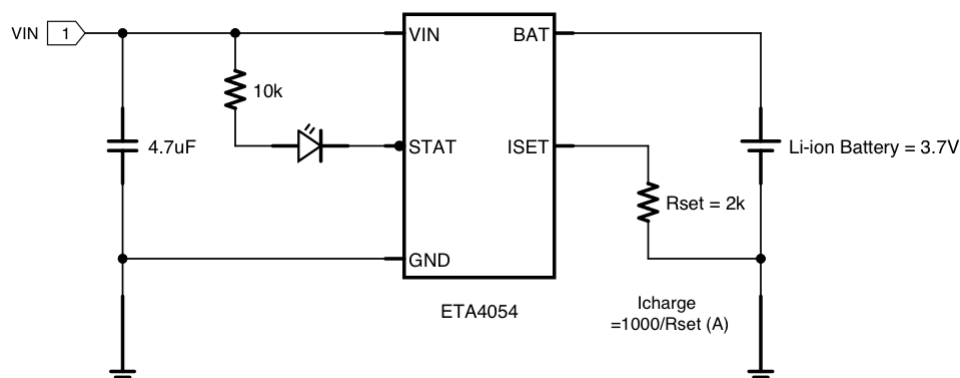

Typical Application Circuit of 500mA Charge Current

PIN CONFIGURATION

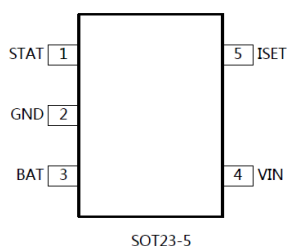

ABSOLUTE MAXIMUM RATINGS

(Note: Exceeding these limits may damage the device. Exposure to absolute maximum rating conditions for long periods may affect device reliability.)

VIN Voltage	-0.3V to 20V
BAT Voltage	-0.3V to 16V
All other pin Voltage.....	-0.3V to 6V
Operating Temperature Range	-40°C to 85°C
Storage Temperature Range	-55°C to 150°C
Thermal Resistance	θ_{JA} θ_{JC}
SOT23-5	190.....50..... °C/W
Lead Temperature (Soldering, 10ssec)	260°C
ESD HBM (Human Body Mode)	2KV
ESD MM (Machine Mode)	200V

ELECTRICAL CHARACTERISTICS

(VIN = 5V, unless otherwise specified. Typical values are at TA = 25°C.)

PARAMETER	CONDITIONS	MIN	TYP	MAX	UNITS
Input Supply Voltage		4.25		16	V
Input Over-Voltage Protection Voltage			7		V
Input Voltage Range for Charging		4.25		6	V
Input Supply Current	Charge Mode (Note 1)		300	2000	μA
	Standby Mode (Charge Terminated)		60	100	μA
	Shutdown Mode (ISET Not Connected, VIN < VBAT, or VIN < VULO)		25	50	μA
Regulated Output (Float) Voltage	IBAT = 40mA	4.158	4.2	4.242	V
BAT Pin Current	Rset = 10K, Current Mode	85	100	115	mA
	Rset = 2K, Current Mode	450	500	550	mA
	Standby Mode, VBAT = 4.2V	0	-2	-3	μA
	Shutdown Mode, ISET Not Connected		0.25	0.35	μA
	Sleep Mode, VIN = 0V		0.25	0.35	μA
Trickle Charge Current	VBAT < VTRIKL, Rset = 2K	20	50	80	mA
Trickle Charge Threshold Voltage	VBAT Rising	2.75	2.93	3.09	V
Trickle Charge Hysteresis Voltage		100	130	165	mV
VIN Undervoltage Lockout Threshold	From VIN Low to High	3.05	3.35	3.60	V
VIN Undervoltage Lockout Hysteresis		0.4	0.55	0.65	V
Manual Shutdown Threshold Voltage	ISET Pin Rising	1.10	1.20	1.30	V
	ISET Pin Falling	0.8	1	1.13	V
VIN-VBAT Lockout Threshold Voltage	VIN from Low to High	70	100	140	mV
	VIN from High to Low	10	30		mV

PARAMETER	CONDITIONS	MIN	TYP	MAX	UNITS
C/IO Termination Current Threshold	Note 2	0.085	0.1	0.115	mA/mA
ISET Pin Voltage	Current Mode, VBAT=4V	0.93	1	1.07	V
STAT/STDBY Pin Weak Pull-Down Current	V_STAT = 5V			1	μA
STAT/STDBY Pin Output Low Voltage	I_STAT or I_STDBY= 5mA		0.35	0.6	V
Recharge BAT Threshold Voltage	VFLOAT - VRECHRG	90	120	150	mV
Junction Temperature in Constant Temperature Mode			120		°C
Power FET "ON" Resistance (Between VCC and BAT)			0.5		ohm
Soft-Start Time	IBAT = 0 to IBAT =1000V/RSET		100		μs
Recharge Comparator Filter Time	VBAT High to Low	0.5	5	20	ms
Termination Comparator Filter Time	IBAT Falling Below ICHG/10	400	1000	2500	μs
ISET Pin Pull-Up Current			1		μA

Note 1: Supply current includes ISET pin current (approximately 100μA) but does not include any current delivered to the battery through the BAT pin (approximately 100mA).

Note 2: ITERM is expressed as a fraction of measured full charge current with indicated ISET resistor

PIN DESCRIPTION

SOT23-5 PIN #	NAME	DESCRIPTION
1	STAT	Open-Drain Charge Status Output. The STAT pin outputs low when the battery is charging. Upon the completion of the charge cycle, it becomes high-impedance.
2	GND	Ground.
3	BAT	Charge Current Output. This pin provides charge current to the battery and regulates the final float voltage to 4.2V which is set by an internal precision resistor divider.
4	VIN	Positive Input Supply. Needs to be bypassed with at least a 1μF capacitor.
5	ISET	Program, Monitor the charge current and Shutdown. This pin set to 1V in constant-current mode. The charge current is programmed by connecting a 1% resistor (Rset), between ISET, to GND pin. The charge current can be calculated using the following formula: $I_{BAT} = (V_{ISET}/Rset) \cdot 1000$ The ISET pin can also be used to switch the charger to shutdown mode by disconnecting the program resistor from ground.

FUNCTIONAL DESCRIPTIONS

The ETA4054 is a single cell, fully integrated constant current (CC)/constant voltage (CV) Li-ion battery charger. It can deliver up to 800mA of charge current with a final float voltage accuracy of 1%. The ETA4054 has a build-in thermal regulation circuitry that ensures its safe operation. No blocking diode or external current sense resistor is required; hence reduce the external components for a basic charger circuit to two. The ETA4054 is also capable of operating from a USB power source.

Normal Charge Cycle

The ETA4054 initiates a charge cycle once the voltage at the VIN pin rises above the UVLO threshold level. A 1% precision resistor needs to be connected from the ISET pin to ground. If the voltage at the BAT pin is less than 2.9V, the charger enters trickle charge mode. In this mode, the charge current is reduced to nearly 1/10 the programmed value until the battery voltage is raised to a safe level for full current charging.

The charger switches to constant-current mode as the BAT pin voltage rises above 2.9V, the charge current is thus resumed to full programmed value. When the final float voltage (4.2V) is reached, the ETA4054 enters constant-voltage mode and the charge current begins to decrease until it drops to 1/10 of the preset value and ends the charge cycle!

Programming Charge Current

The charge current is programmable by setting the value of a precision resistor connected from the ISET pin to ground. The charge current is 1000 times of the current out of the ISET pin. The program resistor and the charge current are calculated using the following equations:

$$R_{set} = \frac{1000V}{I_{CHG}}$$

The charge current out of the BAT pin can be determined at any time by monitoring the ISET pin voltage using the following equation:

$$I_{BAT} = \frac{V_{ISET}}{R_{set}} \cdot 1000$$

Charge Termination

The ETA4054 keeps monitoring the ISET pin during the charging process. It terminates the charge cycle when the charge current falls to 1/10 the programmed value after the final float voltage is reached. When the ISET pin voltage falls below 100mV for longer than tTERM (typically 1ms), charging is terminated. The charge current is latched off and the ETA4054 enters standby mode, where the input supply current drops to 200µA. (Note: C/10 termination is disabled in trickle charging and thermal limiting modes).

During charging, the transient response of the circuit can cause the ISET pin to fall below 100mV temporarily before the battery is fully charged, thus can cause a premature termination of the charge cycle. A 1ms filter time on the termination comparator can prevent this from happening. Once the average charge current drops below 1/10 the programmed value, the ETA4054 terminates the charge cycle and ceases to provide any current through the BAT pin. In this state, all loads on the BAT pin must be supplied by the battery.

The ETA4054 constantly monitors the BAT pin voltage in standby mode and resume another charge cycle if this voltage drops below the recharge threshold. User can also manually restart a charge cycle in standby mode either by removing and then reapplied the input voltage or restart the charger using the ISET pin.

Charge Status Indicator (STAT pin)

There are 2 different states of the charge status output, namely strong pull-down ($\sim 10\text{mA}$) and high impedance. The strong pull-down state indicates that the ETA4054 is in a charge cycle. When the charge cycle has terminated, the pin state is then determined by under-voltage lockout conditions. If VIN meets the UVLO conditions, device is in high-impedance status and is ready to charge. If the difference between VIN and BAT pin voltage is less than 100mV or insufficient voltage is applied to the VIN pin, High impedance appears on the charge status pin.

High Temperature Fold-back

Build-in feedback circuitry mechanism can reduce the value of the programmed charge current once the die temperature tends to rise above 50°C, hence prevents the temperature from further increase and ensure device safe operation.

Under-voltage Lockout (UVLO)

Build-in under-voltage lockout circuit monitors the input voltage and keeps the charger in shutdown mode until VIN rises above the under-voltage lockout threshold. The UVLO circuit has a built-in hysteresis of 200mV. Furthermore, to protect against reverse current in the power MOSFET, the UVLO circuit keeps the charger in shutdown mode if VIN falls to within 30mV of the battery voltage. If the UVLO comparator is tripped, the charger will not come out of shutdown mode until VIN rises 100mV above the battery voltage.

Manual Shutdown

Floating the ISET pin by removing the resistor from ISET pin to ground can put the device in shutdown mode. The battery drain current is thus reduced to $<5\mu\text{A}$ and the supply current to $<50\mu\text{A}$. Reconnecting the resistor back will restart a new charge cycle. Once manually shutdown, the ISET pin is in a high impedance state.

Automatic Recharge

After the termination of the charge cycle, the ETA4054 constantly monitors the BAT pin voltage and starts a new charge cycle when the battery voltage falls below 4.05V, keeping the battery at fully charged condition. ISET pin output enters a strong pull-down state during recharge cycles.

BLOCK DIAGRAM

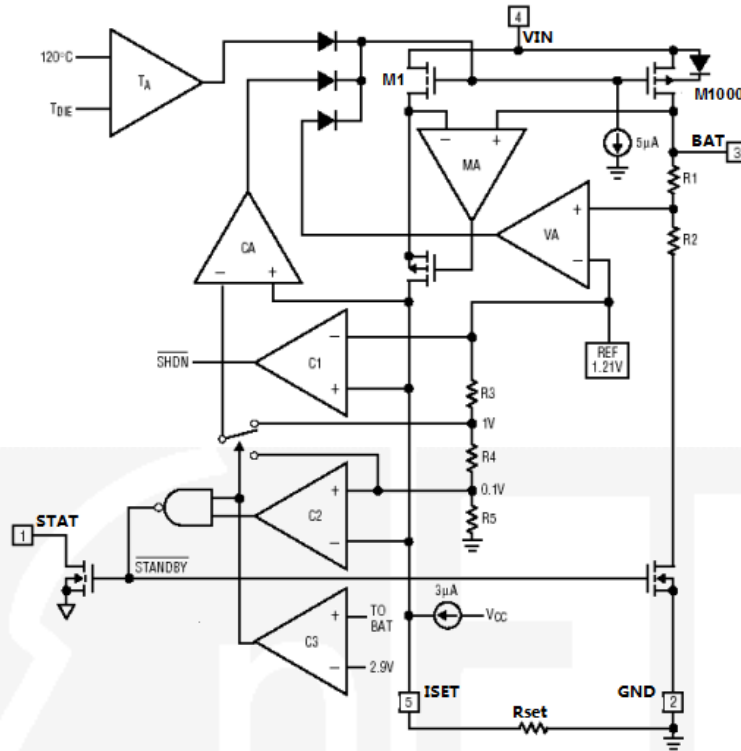

PACKAGE OUTLINE

Package: SOT23-5

