

General Description

The AP9809 is a current-mode and fixed frequency boost converter with an integrated N-FET to drive up to 8~10 white LEDs in series. The series connection allows the LED current to be identical for uniform brightness. Its low on resistance of N-FET and feedback voltage reduce power loss and achieve high efficiency. Fast 1.1MHz current-mode PWM operation is available for input and output capacitors and a small inductor while minimizing ripple on the input supply. The OVP pin monitors the output voltage and stops switching if exceeds the over-voltage threshold. An internal soft-start circuit eliminates the inrush current during start-up.

The AP9809 also integrates under-voltage lockout, over-temperature protection, and current limit circuits. The AP9809 is available in a SOT-23-6 package.

FEATURES

- Wide input Voltage from 2.5V to 6V
- 0.3V Reference Voltage
- Fixed 1.1MHz Switching Frequency
- High Efficiency up to 87%
- Wide Range for PWM Dimming (100Hz to 200kHz)
- Under-Voltage Lockout Protection
- Over-Temperature Protection
- 40V Over voltage protection
- $1\mu\text{A}$ Quiescent current During Shutdown
- SOT23-6 Package
- Lead Free and Green Devices Available (ROHS Compliant)

Applications

- Cell Phone and Smart Phone
- PDA, PMP, MP3
- Digital Camera
- White LED Display Backlighting

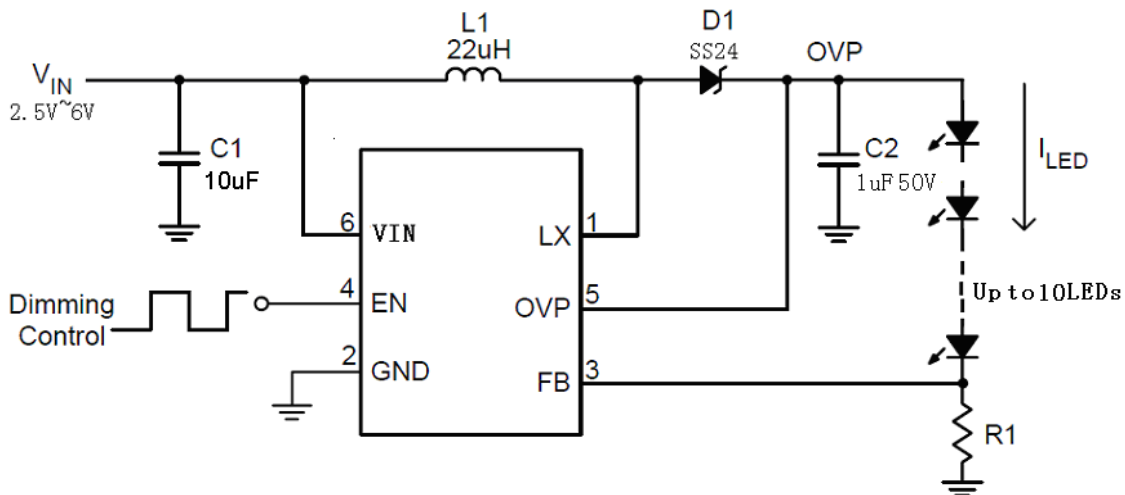

Figure 1. Typical Application Circuit 1

ORDERING INFORMATION

PART NUMBER	TEMP RANGE	SWICHING FREQUENCY	OVP (V)	ILIM (A)	PACKAGE	PINS
AP9809	-40°C to 85°C	1.1MHZ	40	1.3	SOT23-6	6

PIN CONFIGURATION

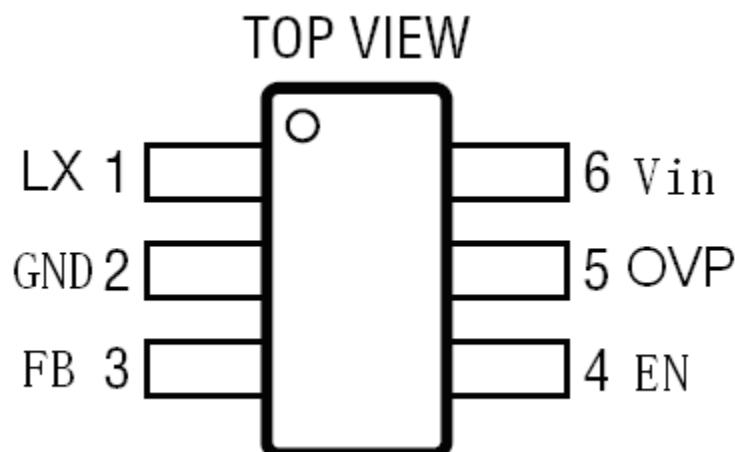

Figure 2. PIN Configuration

PIN DESCRIPTION

PIN NUMBER	PIN NAME	PIN DESCRIPTION
1	LX	Switch pin, Connect this pin to inductor/diode here.
2	GND	Ground.
3	FB	Feedback Input, Reference voltage is 0.3V, Connect this pin to cathode of the lowest LED calculate resistor value according to $R1=0.3V/I_{led}$.
4	EN	Enable Input. When higher than 1.5V, this pin turns the IC on. When lower than 0.3V, this pin turns the IC off. Do not leave this pin floating.
5	OVP	Output Voltage Sense Input. The NMOS switch gate drive is derived from the greater of V_{out} and V_{in} Over-Voltage Protection Input Pin.
6	Vin	Power supply

ABSOLUTE MAXIMUM RATINGS

(Note: Do not exceed these limits to prevent damage to the device. Exposure to absolute maximum rating conditions for long periods may affect device reliability.)

PARAMETER	VALUE	UNIT
Supply Voltage VIN	-0.3 to 6.5	V



FB, EN Voltage	-0.3 to VIN+0.3	V
SW Voltage	45	V
Operating Ambient Temperature	-40 to 85	°C
Maximum Junction Temperature	125	°C
Storage Temperature	-55 to 150	°C
Lead Temperature (Soldering, 10 sec)	300	°C

ELECTRICAL CHARACTERISTICS

(VIN = 3.6V, TA = 25°C unless otherwise specified)

PARAMETER	SYMBOL	TEST CONDITIONS	MIN	TYP	MAX	UNIT
Input Voltage Range	VIN		2.5		6.0	V
Operating Supply Current	Iq	VFB = 1.5V, No Switching		150	220	μA
Shutdown Supply Current		VEN = 0V,		0.1	1	
Regulated Feedback Voltage	VFB	Ven = 1.5V	0.285	0.300	0.315	V
Under Voltage Lockout	UVLO		2	2.2	2.4	V
Under Voltage Lockout Hysteresis				100		mV
Open Lamp Shutdown Threshold	OVP			40		V
Peak Inductor Current	IPEAK	Duty Cycle = 60%		1.3		A
Oscillator Frequency	FOSC			1.1		MHz
Rds(ON) of N-channel FET	Rds(ON)	ISW = -100mA		0.35		Ohm
Enable Threshold		VIN = 2.5V to 6V	0.4	1	1.5	V
Enable Leakage Current			-0.1		+0.1	μA
SW Leakage Current		VEN = 0V, VSW = 0V or 5V, VIN = 5V			1	uA

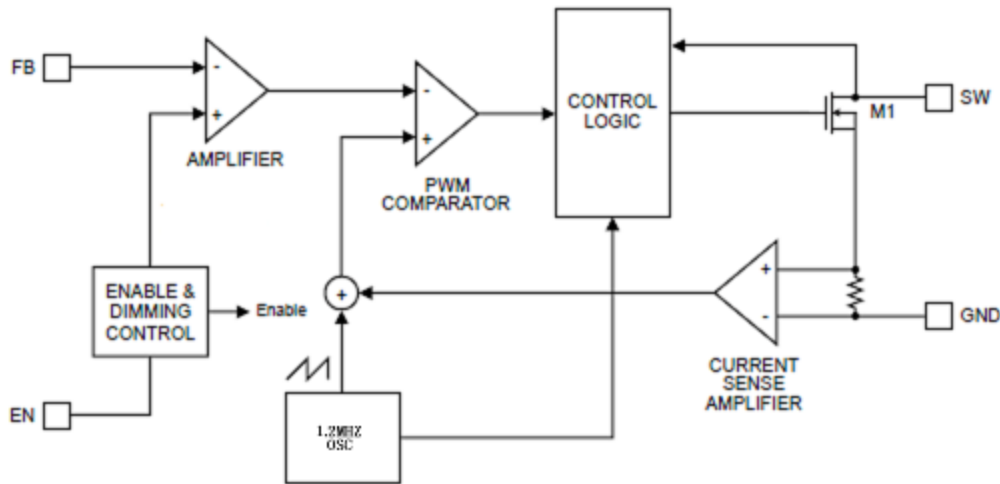

Figure 3. Functional Block Diagram

FUNCTIONAL DESCRIPTION

NORMAL OPERATION

The AP9809 uses a constant frequency, peak current mode boost regulator architecture to regulate the series string of white LEDs. The operation of the AP9809 can be understood by referring to the block diagram of Figure 3.

At the start of each oscillator cycle the FET is turned on through the control circuitry. To prevent sub-harmonic oscillations at duty cycles greater than 50 percent, a stabilizing ramp is added to the output of the current sense

amplifier and the result is fed into the positive input of the PWM comparator. When this voltage equals the output voltage of the error amplifier the power FET is turned off.

If the feedback voltage starts to drop, the output of the error amplifier increases. This results in more current flowing through the power FET, thus increasing the power delivered to the output.

APPLICATION INFORMATION

LED CURRENT CONTROL

The AP9809 regulates the LED current by setting the current sense resistor (R1) connecting to feedback and ground. As shown as below, The LED current (I_{LED}) can be set by a resistor R1. In order to have an accurate LED current, a precision resistor is preferred (1% is recommended).

$$I_{led} = 0.3/R1$$

DIMMING CONTROL

a. Using a PWM Signal to EN Pin

For the brightness dimming control of the AP9809, the IC provides typically 300mV feedback voltage when the EN pin is pulled constantly high. However, EN pin allows a PWM signal to reduce this regulation voltage by changing the PWM duty cycle to achieve LED brightness dimming control. The relationship between the duty cycle and FB voltage can be calculated as following equation :

$$V_{fb} = \text{Duty} * 300\text{mV}$$

Where

Duty = duty cycle of the PWM signal

300mV = internal reference voltage

As shown in Figure 4, the duty cycle of the PWM signal

is used to cut the internal 300mV reference voltage. An internal low pass filter is used to filter the pulse signal. And then the reference voltage can be made by connecting the output of the filter to the error amplifier for the FB pin voltage regulation.

However, the internal low pass filter 3db frequency is 500Hz. When the dimming frequency is lower than 500Hz, V_A is also a PWM signal and the LED current is controlled directly by this signal. When the frequency is higher than 500Hz, PWM is filtered by the internal low pass filter and the V_A approach a DC signal. And the LED current is a DC current which eliminate the audio noise. Two figures of PWM Dimming from EN are shown in Typical Operating Characteristics section and the PWM dimming frequency is 200Hz and 20kHz respectively. But there is an offset in error amplifier which will cause the V_A variation. In low PWM duty signal situation, the filtered reference voltage is low and the offset can cause bigger variation of the output current. The minimum duty vs frequency is listed in following table..

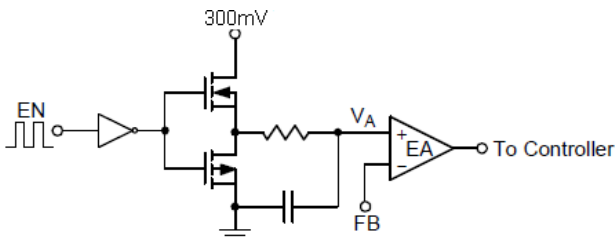
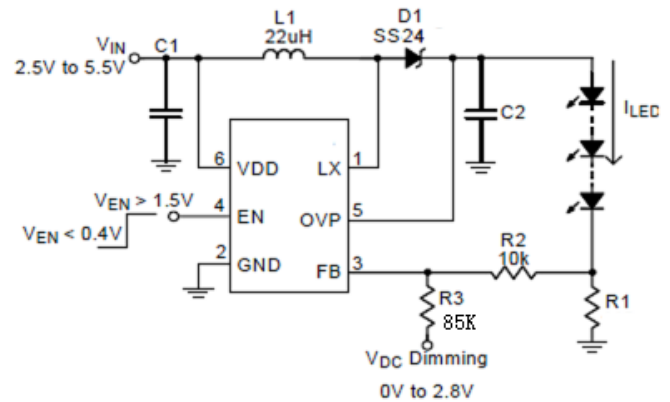

Figure 4. Block Diagram of Programmable FB Voltage Using PWM Signal

	Duty Minimum
Dimming frequency < 500Hz	4%
Dimming frequency > 500Hz	10%

b. Using a DC Voltage

Using a variable DC voltage to adjust the brightness is a popular method in some applications. The dimming control using a DC voltage circuit is shown in Figure 5. According to the Superposition Theorem, as the DC voltage increases, the voltage contributed to V_{FB} increases and the voltage drop on R2 decreases, i.e. the LED current decreases. For example, if the V_{DC} range is from 0V to 2.8V, the selection of resistors in Figure 5 sets dimming control of LED current from 20mA to 0mA.



The LED current can be calculated by the following equation.

$$I_{LED} = \frac{V_{FB} - \frac{R2 \times (V_{DC} - V_{FB})}{R3}}{R1}$$

c. Using a Filtered PWM signal :

Another common application is using a filtered PWM Signal as an adjustable DC voltage for LED dimming control. A filtered PWM signal acts as the DC voltage to regulate the output current. The recommended application circuit is shown in the Figure 6. In this circuit, the output ripple depends on the frequency of PWM signal. For smaller output voltage ripple (<100mV), the recommended frequency of 2.8V PWM signal should be above 2kHz. To fix the frequency of PWM signal and change the duty cycle of PWM signal can get different output current as Figure 7. According to the application circuit of Figure 6, output current is from 18.7mA to 1.16mA by adjusting the PWM duty cycle from 5% to 95%.

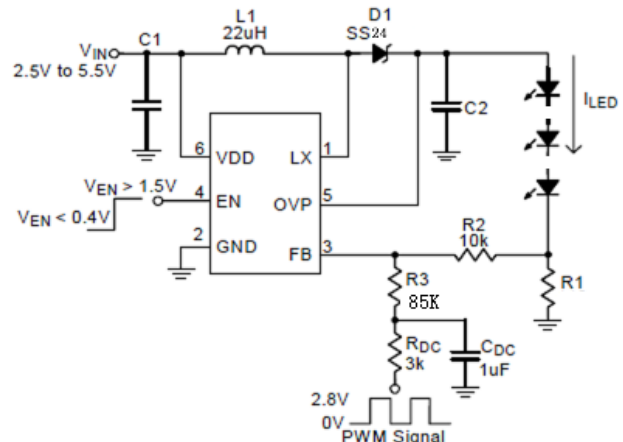



The LED current can be calculated by the following equation.

$$I_{LED} = \frac{V_{FB} - \frac{R2 \times (V_{PWM} \times Duty - V_{FB})}{R3 + R_{DC}}}{R1}$$

INDUCTOR SELECTION

The recommended value of inductor for 8 to 10 WLEDs applications are 22μH. Small size and better efficiency are the major concerns for portable device, such as AP9809 used for mobile phone. The inductor should have low core loss at 1.1MHz and low DCR for better efficiency. To avoid inductor saturation current rating should be considered.

Table 1. Recommend Surface Mount Inductors

Manufacturer	Part Number	Inductance(uH)	DRC max (Ohms)	Dimensions L*W*H(mm ³)
Murata	LQH32PN	22	0.15	3.2*2.5*1.7
Sumida	CDRH3D16	22	0.17	4*4*1.8

LAYOUT GUIDE

- 1) VCC to GND noise bypass-Short and wide connection for the 1 MLCC capacitor between Pin6 and Pin2.
- 2) Minimized LX node copper area to reduce EMI.
- 3) Minimized FB node copper area and keep far away from noise sources
- 4) A full GND plane without gap break

MULTI-CHANNEL LEDS' APPLICATION (3*12)

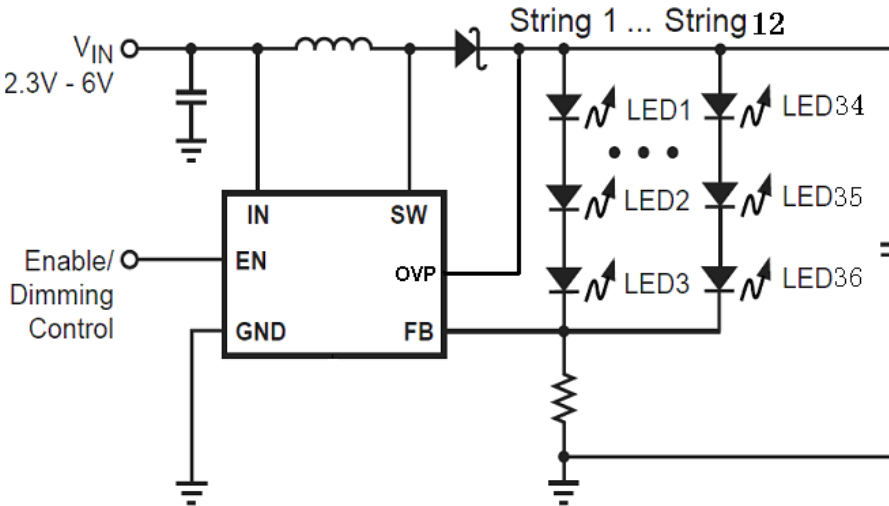

INPUT & OUTPUT CAPACITOR SELECTION

Input ceramic capacitors of 10μF and output of 1uF are recommended for AP9809 applications. For better voltage filtering, ceramic capacitors with low ESR are recommended. X5R and X7R types are suitable because of their wider voltage and temperature ranges. Such as Murata GRM32RR71H105KA01L and GRM32ER61A106KA01L

DIODE SELECTION

Schottky diode is a good choice for AP9809 because of its low forward voltage drop and fast reverse recovery. Using Schottky diode can get better efficiency.. The ONSEMI SS24 and Diodes B240A is recommend.

TYPICAL PERFORMANCE CHARACTERISTICS

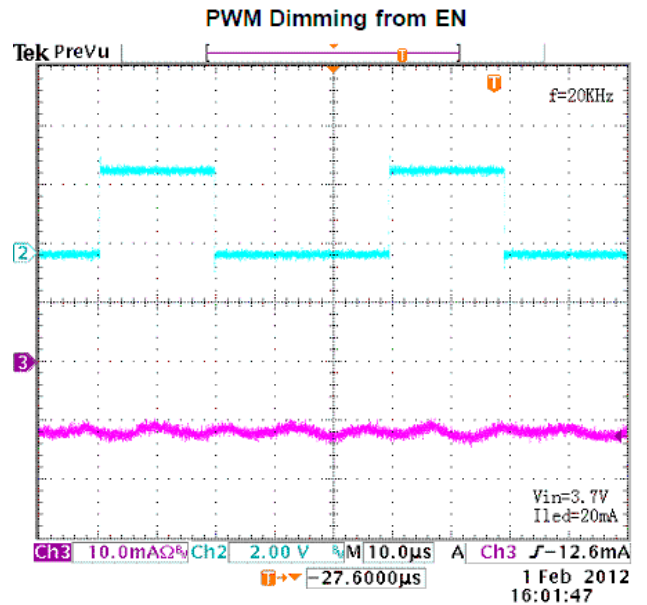
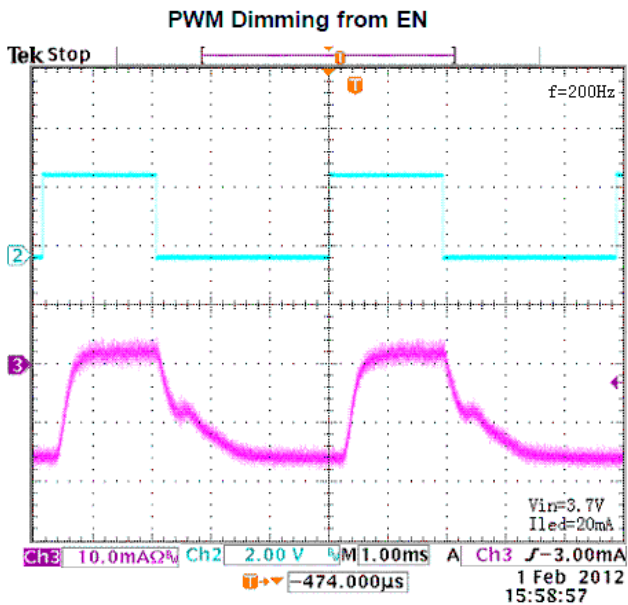
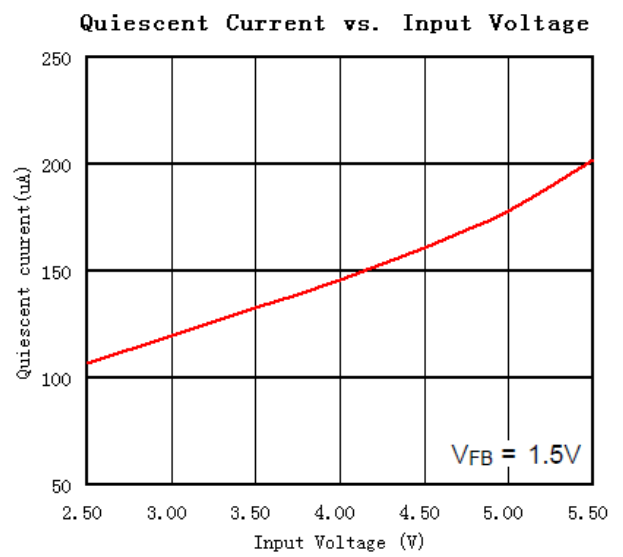
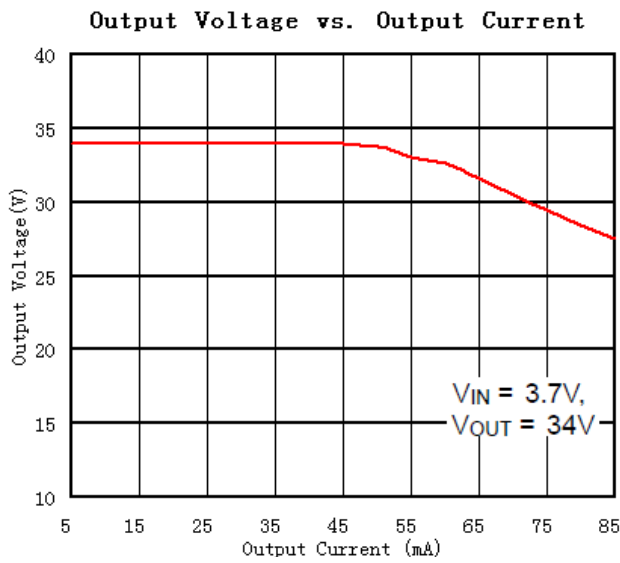
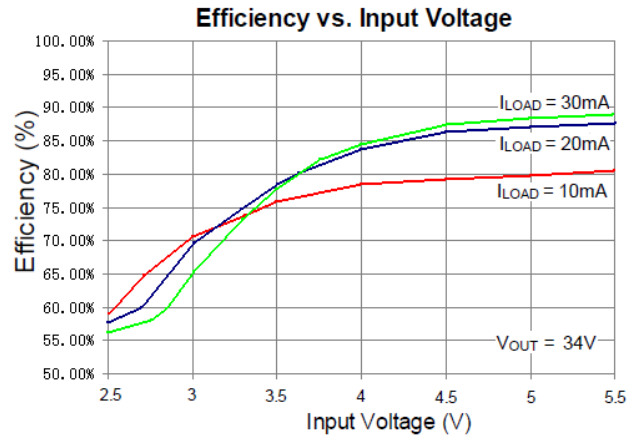
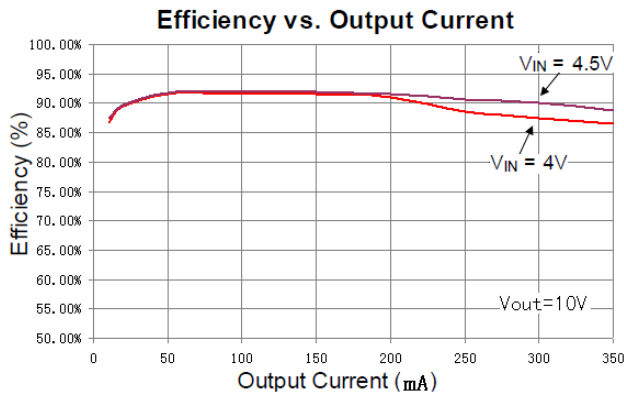

OVP Output at Open Load

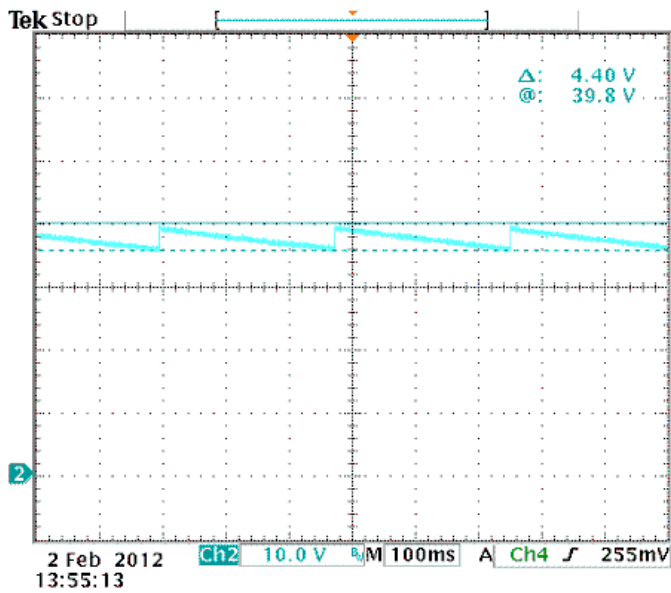

Enable Voltage vs. Input Voltage

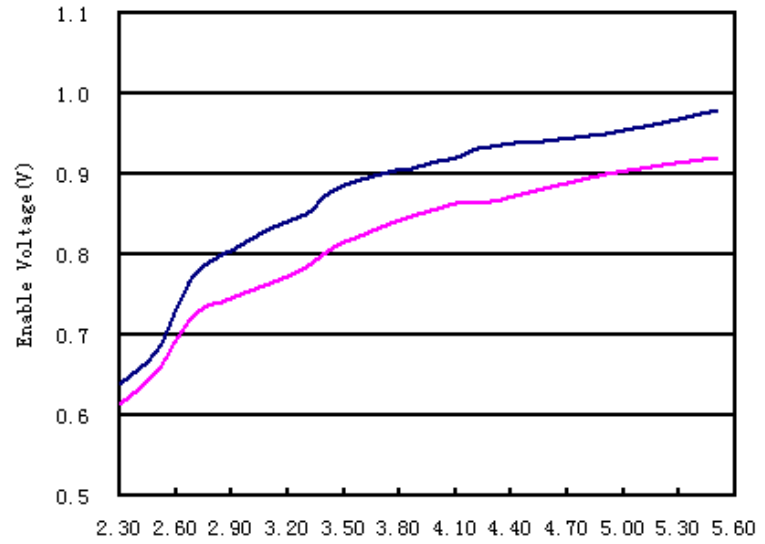

Ripple Voltage

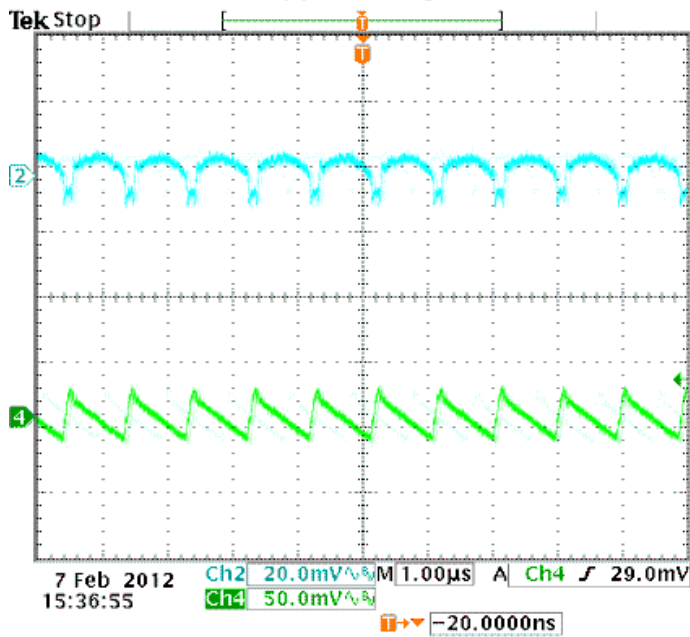

PACKAGE OUTLINE

SOT-23-6L PACKAGE OUTLINE DIMENSIONS

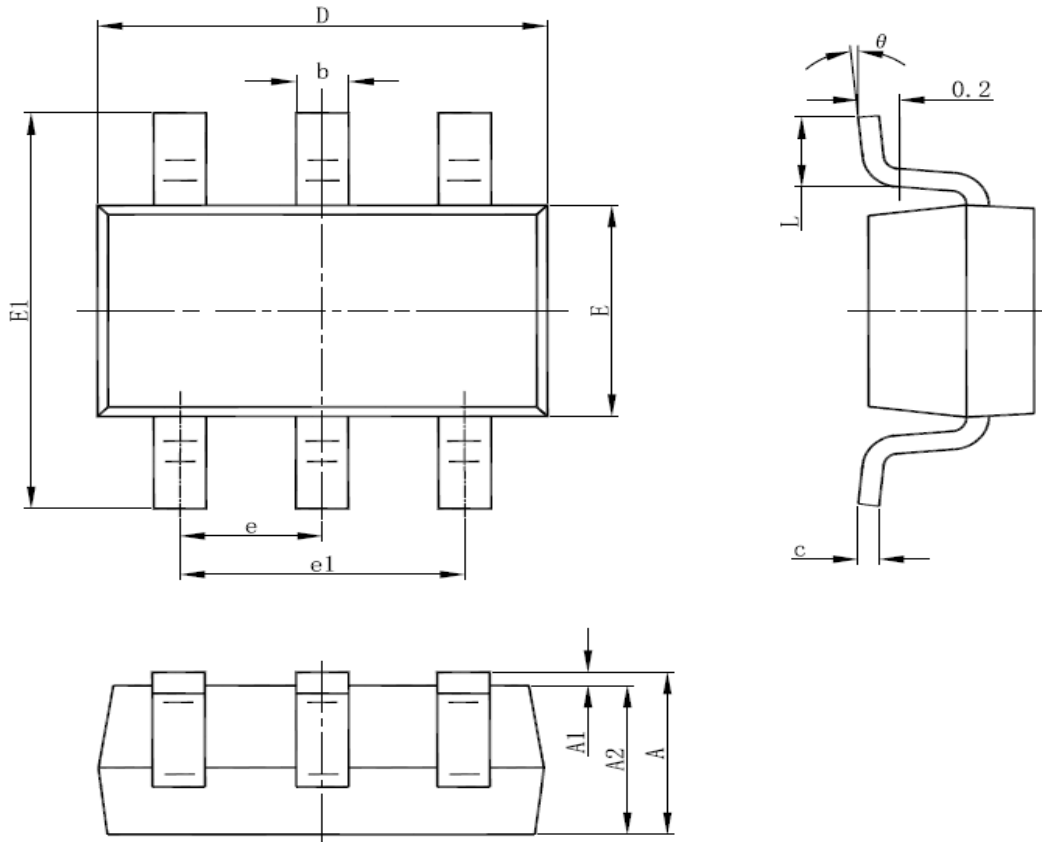

Symbol	Dimensions In Millimeters		Dimensions In Inches	
	Min	Max	Min	Max
A	1.050	1.250	0.041	0.049
A1	0.000	0.100	0.000	0.004
A2	1.050	1.150	0.041	0.045
b	0.300	0.500	0.012	0.020
c	0.100	0.200	0.004	0.008
D	2.820	3.020	0.111	0.119
E	1.500	1.700	0.059	0.067
E1	2.650	2.950	0.104	0.116
e	0.950(BSC)		0.037(BSC)	
e1	1.800	2.000	0.071	0.079
L	0.300	0.600	0.012	0.024
θ	0°	8°	0°	8°