

LOAD:	10 kg	25 kg	50 kg	100 kg	200 kg	500 kg	1 t	1.5 t	2 t
Class C2	CF310KC25	CF325KC25	CF350KC25	CF3100KC25	CF3200KC25	CF3500KC25	CF31TC25	CF31T5C25	CF32TC25
Class C3	/	/	CF350KC35	CF3100KC35	CF3200KC35	CF3500KC35	CF31TC35	CF31T5C35	CF32TC35

Dimensioni *Dimensions*

[mm]

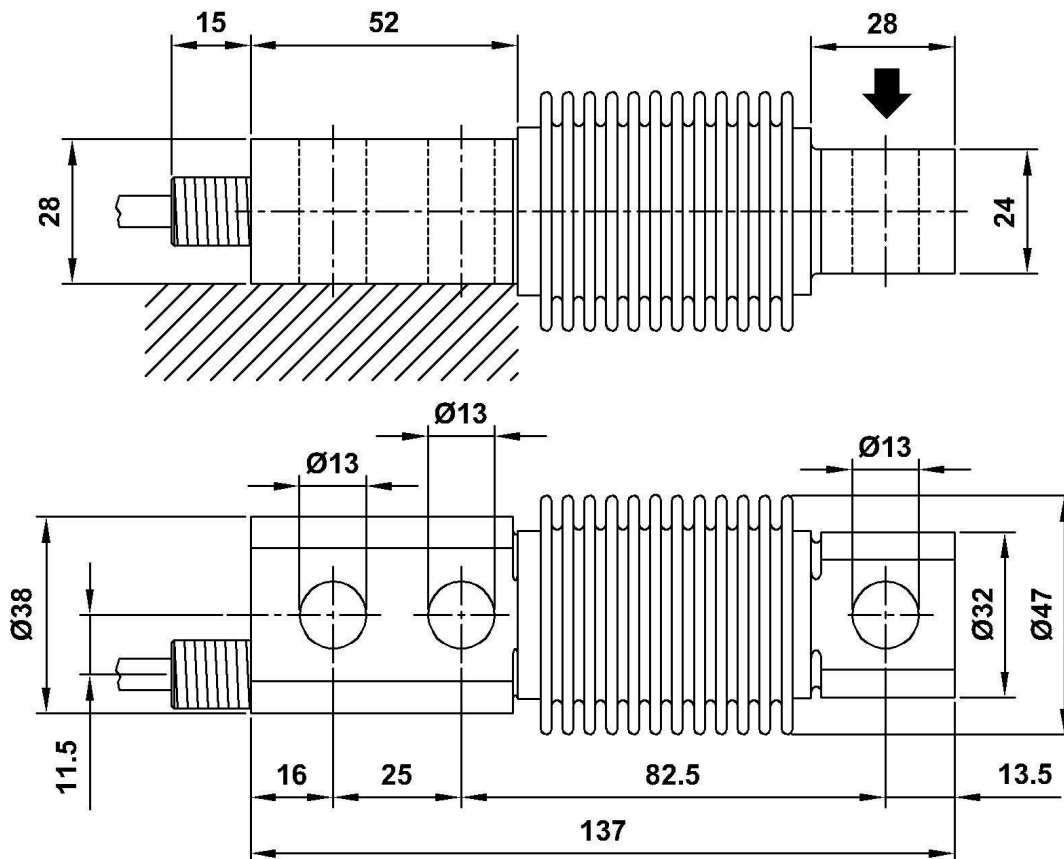

Dati Tecnici

Technical Data



CLASSE DI PRECISIONE: OIML R60	ACCURACY CLASS: OIML R60	C2	C3
DIVISIONI	DIVISIONS	2000	3000
CARICO NOMINALE (E_{max})	NOMINAL LOAD (E_{max})	10-25-50-100-200-500kg 1-1.5-2 t	50-100-200-500 kg 1-1.5-2 t
DIVISIONE MINIMA DI VERIFICA (V_{min})	MINIMUM VERIFICATION DIVISION (V_{min})	$E_{max} / 10000$	
ERRORE COMBINATO NON RIPETIBILITA' RITORNO A ZERO dopo 30 min. CREEP al carico nominale: a) dopo 30 min. b) dopo 20 e 30 min.	COMBINED ERROR NON REPEATABILITY TOLERANCE ON ZERO over 30 min. CREEP to nominal load: a) over 30 min. b) over 20 and 30 min.	$\leq \pm 0.027\%$ $\leq \pm 0.015\%$ $\leq \pm 0.021\%$ $\leq \pm 0.028\%$ $\leq \pm 0.012\%$	$\leq \pm 0.018\%$ $\leq \pm 0.011\%$ $\leq \pm 0.015\%$ $\leq \pm 0.012\%$ $\leq \pm 0.010\%$
EFFETTO DELLA TEMPERATURA 10 °C a) sullo zero b) sulla sensibilità	TEMPERATURE EFFECT 10 °C a) on zero b) on sensitivity	$\leq \pm 0.023\%$ $\leq \pm 0.010\%$	$\leq \pm 0.013\%$ $\leq \pm 0.009\%$
SENSIBILITA' NOMINALE TOLLERANZA DI CALIBRAZIONE	NOMINAL SENSITIVITY SENSIVITY TOLERANCE	2mV/V $\leq \pm 0.1\%$	
RESISTENZA DI INGRESSO RESISTENZA DI USCITA RESISTENZA DI ISOLAMENTO BILANCIAMENTO DI ZERO ALIMENTAZIONE DI RIFERIMENTO ALIMENTAZIONE NOMINALE ALIMENTAZIONE MAX.	INPUT RESISTANCE OUTPUT RESISTANCE INSULATION RESISTANCE ZERO BALANCE RECOMENDED SUPPLY VOLTAGE NOMINAL RANGE VOLTAGE MAXIMUM SUPPLY VOLTAGE	420 \pm 20 Ω 350 \pm 2 Ω > 5 G Ω $\leq \pm 1\%$ 10 V 1-15 V 18 V	
VALORI MECCANICI LIMITE riferiti al carico nominale: a) carico minimo b) carico di servizio c) carico limite d) carico di rottura e) massimo carico trasversale f) carico dinamico limite	MECHANICAL LIMIT values related to nominal load: a) minimum load b) service load c) max permissible load d) breaking load e) maximum side load f) max permissible dynamic load	0% 120% 150% >300% 200% 75%	
FRECCIA MAX. AL CARICO NOMINALE	DISPLACEMENT AT NOMINAL LOAD	~ 0.4 mm	
TEMPERATURA DI RIFERIMENTO CAMPO NOMINALE DI TEMPERATURA TEMPERATURA DI ESERCIZIO TEMPERATURA DI STOCCAGGIO	REFERENCE TEMPERATURE NOMINAL TEMPERATURE RANGE SERVICE TEMPERATURE STORAGE TEMPERATURE	+23°C -10/+40 °C -20/+70 °C -20/+80 °C	
PESO	WEIGHT	~ 1.0 kg	
CLASSE DI PROTEZIONE (EN 60529) MATERIALE DELLA CELLA LUNGHEZZA CAVO	PROTECTION CLASS (EN 60529) CELL MATERIAL CABLE LENGTH	IP67 Acciaio Inox / Stainless Steel 5m	
VITI DI FISSAGGIO: a) diametro b) classe di resistenza c) coppia di serraggio	FIXING SCREWS a) diameter b) resistance class c) tightening torque	M12 12.9 70 Nm	

Accelerazione di gravità $g=9.80434 \text{ m/s}^2$

Gravity acceleration $g=9.80434 \text{ m/s}^2$

Collegamenti Elettrici

Electrical Connections

Cavo schermato PVC 105°C Ø5.2mm a 4 conduttori Ø0.35mm² stagnati.

PVC 105°C shielded cable Ø5.2mm with 4 tinned conductors Ø0.35mm².

Load Cell	OUTPUT	CABLE	CAVO
	EXCITATION+ EXCITATION - OUTPUT+ OUTPUT-	Red Black White Yellow Shield*	Rosso Nero Bianco Giallo Schermo*

* Collegato al corpo della cella di carico.
Connected to the load cell body.