



哈伯精密工業有限公司
HABOR PRECISE INDUSTRIES CO., LTD.

油冷卻機

HBO 系列：油壓・潤滑油專用

OIL COOLER UNIT

HBO Series:
For hydraulic oil & lubricating oil

使用前請先詳閱

Ensure to read this instruction
manual before use.



使用操作手冊 *Instruction Manual*

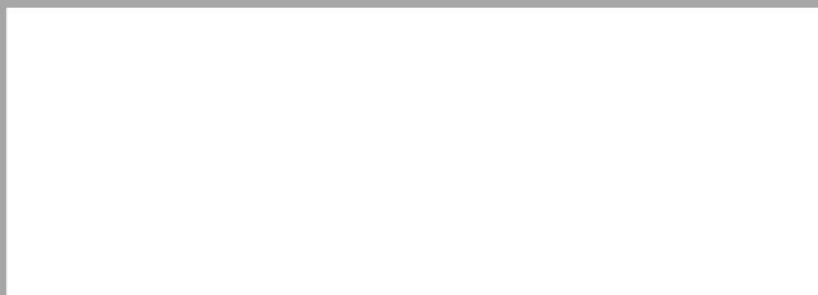

目 錄 CONTENTS

1. 一般安全措施	1
2. 安裝設置	1
2-1 運輸時注意事項	2
2-2 組裝場所	2
2-3 適用油類	3
2-4 配管	3
2-5 電氣配線	5
3. 運轉操作	5
3-1 運轉前檢查事項	5
3-2 控制操作	6
4. 維修保養	8
4-1 清理	8
4-2 儲存	9
5. 泵浦調壓操作說明	9
6. 故障排除	10
6-1 洩漏	10
6-2 OTC異常訊號狀況排除	10
6-3 HB4異常訊號狀況排除	15
6-4 無異常訊號狀況排除	16
1. General Safety Precaution	19
2. Installation	19
2-1 Transportation	20
2-2 Location	21
2-3 Acceptable Oil	21
2-4 Oil piping	22
2-5 Electrical Wiring	23
3. Operation	24
3-1 Checklist before Operating	24
3-2 Operating Control	24
4. Maintenance	26
4-1 Cleaning	27
4-2 Storage	28
5. Adjusting the pump pressure	28
6. Trouble Shooting	29
6-1 Leakage	29
6-2 Trouble Shooting for OTC Alarm	30
6-3 Trouble Shooting for HB4 Alarm	36
6-4 Trouble Shooting without Alarm	37

1. 一般安全措施

在使用本冷卻機前，請先詳讀並了解這些安全要求。使用本冷卻機時，請遵守這些安全要求以避免火災、電擊或人身傷害。

- (1) 維持工作區域乾淨並通光良好：雜亂和昏暗的環境易造成意外。
- (2) 不可在危險環境操作：請勿在潮濕、被雨淋或有潛在爆炸性之場所使用本冷卻機。
- (3) 勿使兒童接近：所有非操作人員皆應在工作區域外的安全場所。
- (4) 使用適當的電線：請使用可承受本冷卻機所設定之額定電流且狀況良好的電源線。
- (5) 穿著適當的服飾：請勿穿寬鬆的衣服、首飾、手鐲、或珠寶以避免被機械的運轉件夾住，並請穿防滑工作鞋。
- (6) 請勿堆積物品在本冷卻機上：請勿在冷卻機上方放置任何物品，物品掉落易造成人員傷害或機械損傷。
- (7) 連接或更換電線前，請先將電源關閉。
- (8) 若有任何修理或更換零件時，請注意下列事項：
 - (A) 首先請將操作開關或線路保護開關OFF，並切掉電源，再更換零件。
 - (B) 若需要用到火氣焊接的場合，請避免火氣直接碰到油或油氣而產生火災。建議在執行前先將冷卻機自油箱取出，並擦乾附於機身上之油液
 - (C) 若需排放冷媒時，請在通風良好場所排放，以防窒息。

2. 安裝設置

本冷卻機是為任何工作母機或專用機等油壓熱源與主軸潤滑及冷卻而設計之冷卻裝置，它在油壓熱源與潤滑系統上能提供高精度的油溫控制。(請見圖1)

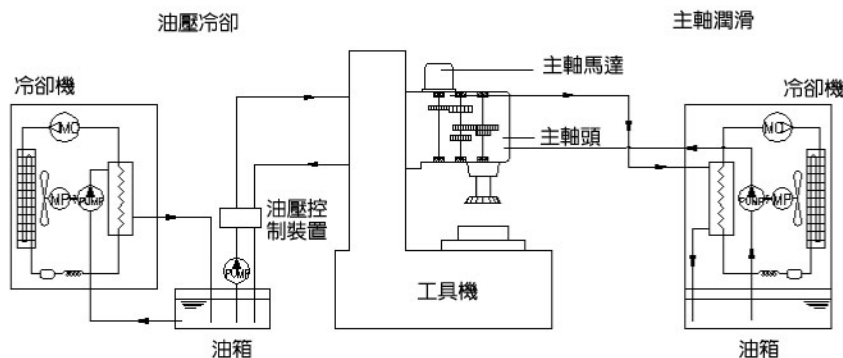

(圖1)

2-1 運輸時注意事項

- (1) 冷卻機搬運時，請勿上下顛倒或過度傾斜；並避免碰撞或撞擊。
- (2) 當運輸或移動冷卻機時，請使用正確的工具(如堆高機或天車)。請勿空手搬動冷卻機。
- (3) 欲移動冷卻機前，請先拆除電源接線並移除系統內之冷卻液。
- (4) 當使用堆高機移動冷卻機時，請確保冷卻機儘可能處於平衡狀態並且高度不高過地面20CM以上(請參考圖2)。
- (5) 以天車移動冷卻機：
 - (A) 請選用有足夠支撐冷卻機重量的天車和繩索。
 - (B) 請注意保持冷卻機之平衡。
 - (C) 移動冷卻機時，所有工作人員都必須和天車保持安全距離且天車繩索的角度需小於45度(如圖3， $\theta \leq 45^\circ$)。

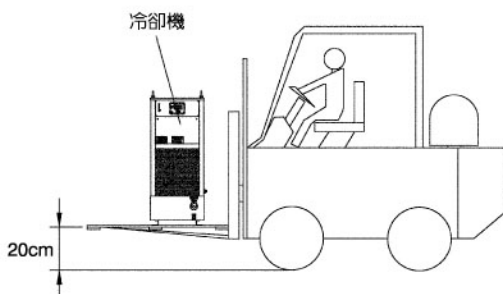

(圖2)

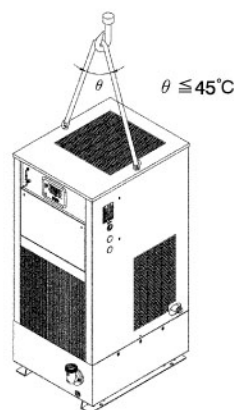

(圖3)

2-2 組裝場所

- (1) 將冷卻機安裝於乾淨的場所。
- (2) 將冷卻機安裝於通風良好的地方。
- (3) 應避免安裝於以下的場所：
 - * 室溫超過40°C的環境。
 - * 會阻擋到進氣口或排氣口的位置。
 - * 有腐蝕性、可燃、塵埃、油霧、導電性粉塵(碳粉、金屬粉)等惡劣空氣之環境。
- (4) 有關冷卻機適用工作溫度範圍請參考圖4。
- (5) 有關冷卻機安裝所需空間請參考圖5。

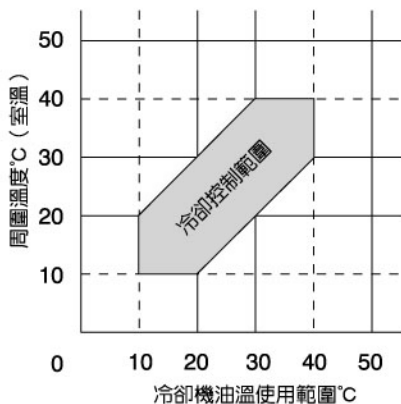

(圖4)

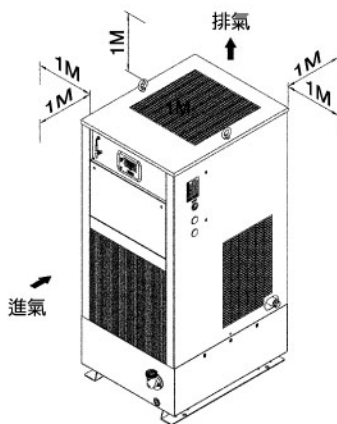

(圖5)

2-3 適用油類

- (1) 本冷卻機適用於礦物系之油壓油和潤滑油，請勿使用下列之液體：
 - * 磷酸酯系油壓油、氯化碳氫系油壓油、水—乙二醇系油壓油及O/W、W/O乳化系油壓油等不燃性做載油。
 - * 切割油、研削油、水及水溶性液體。
 - * 食品、藥品和腐蝕性強的液體。
 - * 汽油、燈油及有機溶劑。
- (2) 本冷卻機應使用之油料黏度須符合 4-300cSt 標準。當使用的油料黏度過高或冷卻機外油配管的油壓損失過大時，泵浦將可能產生不正常的聲響。此時應將冷卻機外油配管的長度縮短並更換為適當黏度的油料。
- (3) 有關油料黏度和溫度的變化以及本冷卻機的油溫 / 黏度之適用範圍請參考圖6。

2-4 配管

- (1) 用於連結本冷卻機至機器的油管及連結件由使用者自行提供。
- (2) 請勿使用剛性材質的油管。請使用有彈性的油管。
- (3) 使用的油管需可承受142psi (10 kgf/cm²)或更高的油壓。
- (4) 使用的油管不應有灰塵或鐵鏽以避免造成熱交換器及泵浦的功能減損而降低冷卻能力，請於冷卻機入口處裝設100-150網目之回油過濾器。
- (5) 冷卻機外的油配管尺寸不可小於冷卻機之進出口管並請使用止洩帶連結以避免空氣進入或漏油，請盡量減少使用閥門及縮短管路長度以減少油壓壓力損失及流量損失。
- (6) 有關機械和冷卻機油路之參考配管請參考圖7。
- (7) 當泵浦因管阻或因室溫變低使油黏度增高而產生噪音時、請參考P.9泵浦的調壓方式、調整泵浦壓力。

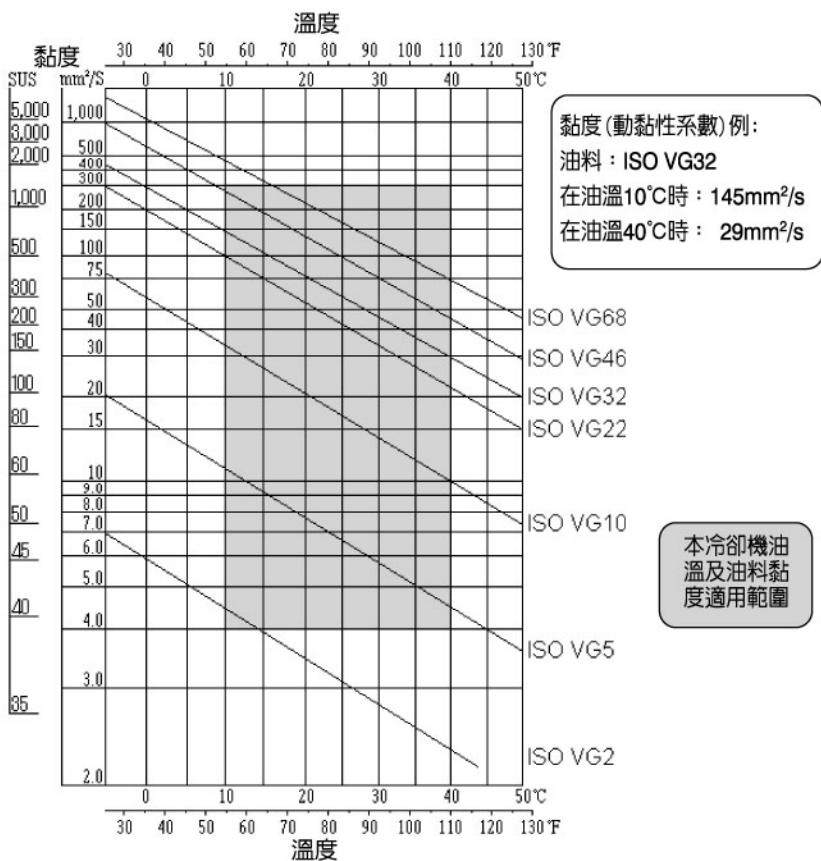

(圖6)

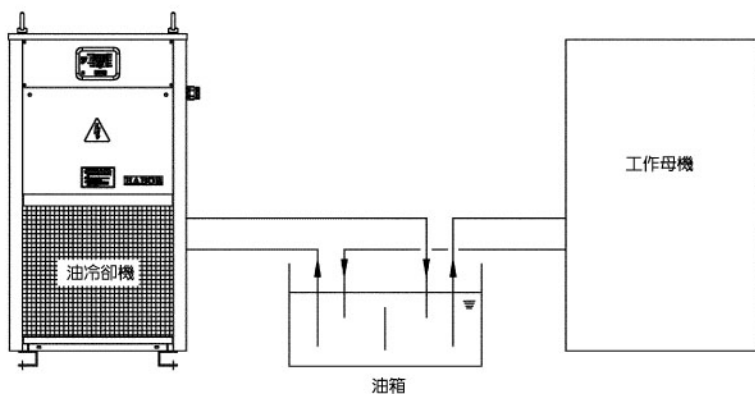

(圖7)

2-5 電氣配線

- (1) 任何配線動作前請注意安全預防措施。
- (2) 連接或更換配線應遵守電氣規格並應由有證照之專業人員執行。
- (3) 請參照電路圖配線。
- (4) 請做好接地工作請勿將接地線接到瓦斯管，避雷針或電話線以避免電擊傷害。
- (5) 請自行裝配漏電斷路器。
- (6) 遠端控制和警報輸出：
欲從裝備端遠端控制冷卻機，可接線至冷卻機的RE1、RE2端子。
如欲將異常訊號輸出至設備端，請連結至冷卻機的11、12端子。

3. 運轉操作

3-1 運轉前檢查事項

- * 輸入電源之電壓和相性是否正確。
- * 油管是否連結正確，是否會漏油。
- * 電氣接線(含接地)是否適當。
- * 油路系統內或油箱內的油量是否充足，油量不足易損害泵浦。
- * 冷卻機安裝地點是否適當，通風良好和室溫正常的工作環境。
- * 連續重複開機易損害冷卻機，運轉中關閉後，請隔3分鐘後再開啓。
- * 油路內是否有空氣。油路內有空氣會造成流量損失並產生異音，移除步驟如下：
 - (A) 輸入電源至冷卻機後，泵浦會開始運轉。
 - (B) 稍微鬆開冷卻機油出口處的油管使空氣從油路系統排出。
 - (C) 空氣排出後，把油管鎖緊並將電源關閉。

3-2 控制操作

(1) OTC控制器

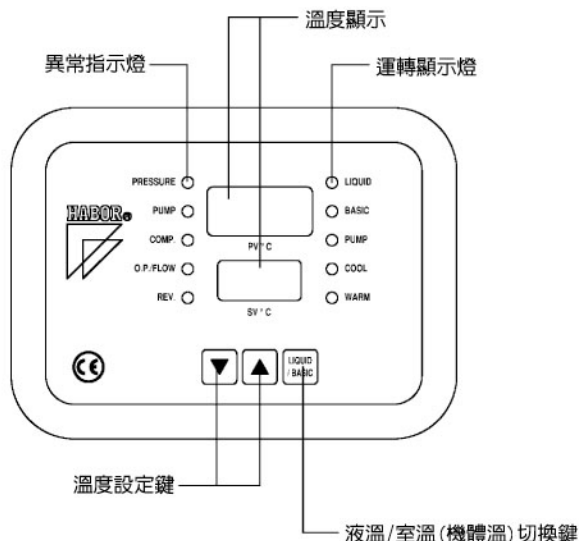

- (A) 溫度顯示：
- PV°C：顯示目前液溫或室溫(機體溫) (請參考(D)液溫/室溫(機體溫)切換鍵)。
 - SV°C：顯示目前溫度設定值。
- (B) 運轉指示燈：
- PUMP：泵浦運轉中亮燈。
 - COOL：壓縮機運轉中亮燈。
 - WARM：加熱器(選加件)運轉中亮燈。
- (C) 溫度設定鍵：
- 請按▼▲鍵來設定需求溫度。
- (D) 液溫/室溫(機體溫)切換鍵：
- 欲了解室溫(機體溫)，按住此鍵則 BASIC燈亮，PV°C 顯示目前室溫(機體溫)；當放開時，LIQUID燈亮，PV°C 顯示目前液溫。(若為溫度固定型控制，則此切換鍵無效)
- (E) 異常指示燈：
- 當冷卻機出現狀況異常而停止運轉時，異常指示燈會因應狀況顯示，請參考 **6-2 OTC異常訊號狀況排除**。

操作說明

打開電源後，SV°C及PV°C會顯示，泵浦會開始運轉，PUMP運轉燈亮。冷卻機將會依設定溫度(SV °C)作恆溫控制。

(A) 溫度設定範圍

溫度固定型：10°C ~ 40°C。

差溫控制型：-10°C ~ +10°C。

(B) 溫度控制方式

溫度固定型：依SV°C值控制液溫。當PV°C高於SV°C時，壓縮機會開始運轉、COOL運轉燈亮；若油溫到達或低於SV°C時，COOL運轉燈滅、壓縮機停止運轉。

差溫控制型：控制液溫和基礎值(室溫或機體溫)保持SV°C值的溫差。

(2) HB4控制器

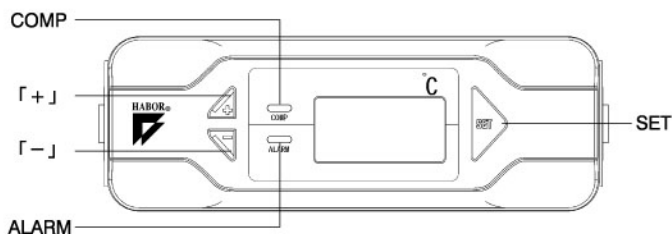

操作說明

(A) 電源輸入，顯示器顯示"888"，顯示現在液溫值，系統開始運作。

(B) 按壓「SET」鍵，顯示"888"閃爍3次後，顯示"t5" (設定值)，再按壓「SET」鍵一次進入設定值，利用「▲」「▼」鍵調整所欲設定的溫度數值。

(C) 再按壓「SET」鍵，顯示"9od"後，返回顯示現在液溫值，即設定完成。

(D) 在顯示設定值狀態下，30秒內不去按壓「SET」「▲」「▼」任一鍵，系統會自動返回現在液溫值。

(E) COMP指示燈，燈亮表示壓縮機運轉中，燈閃爍表示壓縮機延遲啟動中。

(F) ALARM指示燈，燈亮時表示有故障發生請參考上列顯示符號說明

(G) 按「+」鍵，可觀看基礎溫值。

(H) 按「-」鍵時，可觀看設定值。

(I) 當冷卻機出現狀況異常而停止運轉時、面板將顯示各種不同的警報，請參考 6-3 HB4異常訊號狀況排除

4. 維修保養

任何保養動作前請遵守安全預防措施。為維持冷卻機之冷卻效率並延長其使用壽命，冷卻機需定期的保養。要保持一個冷卻機正常運轉需要一個通風良好且無阻塞的工作環境。

4-1 清理

請勿在油冷卻機運轉之下，進行油冷卻機的清潔和保養。在油冷卻機運轉中拆除任何零件會造成人員傷害或機器損傷。

需定期清洗之要件：

- * 機體。
- * 冷凝器。
- * 空氣濾網。
- * 油箱。
- * 濾油網。

請參考詳細的步驟：

(1) 機體

(A) 請用中性清洗劑或高品質肥皂清除冷卻機表面的污垢。請勿使用石類、酸類劑、磨粉、鋼刷、熱水等清洗，保持烤漆完整。

(B) 清洗冷卻機體：在清洗過程中，請勿讓水濺到電器零件。

(C) 擦拭電氣零件部位時，請用擰乾的抹布。

(2) 冷凝器

檢查冷凝器是否被污物阻塞。請定期用壓縮空氣或毛刷清除冷凝器的灰塵。

(3) 空氣濾網

(A) 請將空氣濾網往上拉起並向外抽出，即可卸下。

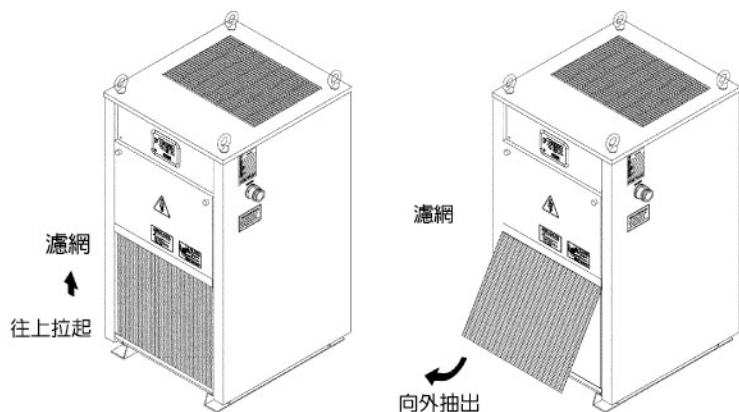

- (B) 請使用吸塵器，空氣噴槍、水管及長毛刷等將過濾網上之灰塵清除。清洗完畢之後，讓濾網乾燥後再裝回。請每週清洗一次。若污垢嚴重，請用中性清洗劑不定期清洗。

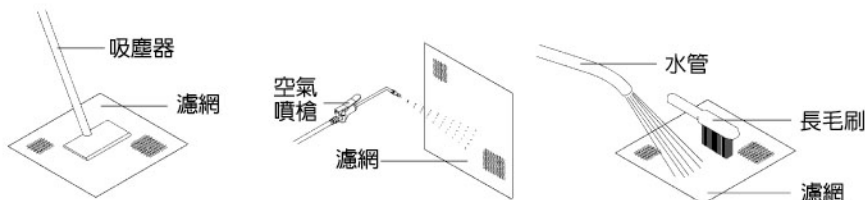

(4) 油箱

若冷卻機安裝於濕氣較重的場所，油箱底部會有水分凝結，請每個月由油箱底部的排油口排除水分。

(5) 濾油網

油管連結後開始階段請每日清潔濾油網，正常運轉後請每2-4日清潔一次

4-2 儲存

長期間停止使用時請注意保護本機內部及冷凝器以防有塵埃、水份附著。

- (1) 請將本機放置在遠離塵埃的地方。
- (2) 將電源線擦拭乾淨。
- (3) 請用保護套以防塵埃、水份附著。
- (4) 請將本機存放在平坦地面、乾燥涼爽的场所。
- (5) 若冷卻機裝有腳輪，請確保腳輪有被固定或鎖緊，以避免腳輪滑動而造成人員傷害。

5. 泵浦調壓操作說明

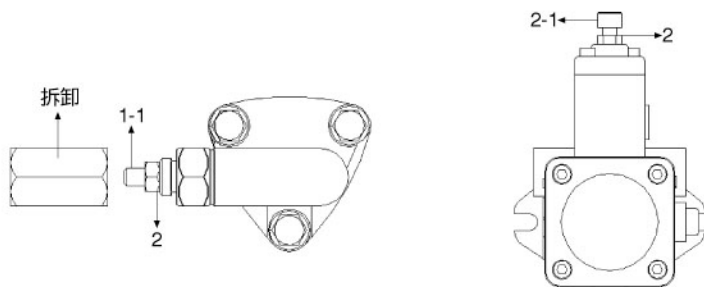

當冷卻機因設備端管路條件不佳或因油黏度改變而產生泵浦噪音時，請調節泵浦作動壓力以改善噪音問題，依機型不同選擇合適之圖示調壓。
注意：調壓動作會造成流量與壓力的改變、請再確認調整過後的流量適合其應用，建議以流量計與壓力表做數據的確認。

- (A) 使用一字起子固定1-1或使用六角板手固定2-1後，再將板手循逆時鐘方向鬆開2。
- (B) 如果泵浦有異音，循逆時鐘方向旋轉1-1或2-1即可洩壓，請依需求做適當調整。
- (C) 如果泵浦有流量不足，循順時鐘方向旋轉1-1或2-1即可加壓，請依需求做適當調整。
- (D) 調整完畢後依(A)循順時鐘方向鎖回各部零件。

6. 故障排除

任何的檢查維修以及故障排除，請遵守安全指示並應由有證照的專業人員來執行。

當冷卻機發生故障或異常時，冷卻機將停止運轉並顯示異常訊號。請對照以下的資料，將狀況排除後重開機恢復運轉。

6-1 洩漏

當從油管部份漏油時，請將管束再鎖緊，或更換管束。

當維修需要用到焊接工具時：

- (1) 需排放冷媒時，請在通風良好場所排放，以防窒息。
- (2) 排出油路和油箱內的油並卸下機械和冷卻機之間的油管以防火災。
- (3) 請依國家的環保要求法規排出並處理冷媒。

6-2 OTC異常訊號狀況排除

(1)	訊號說明	液溫感測器異常警告。
	可能原因	<ul style="list-style-type: none"> * 液溫感測器斷線或接觸不良。 * 液度控制器故障。
	檢查方法	<ul style="list-style-type: none"> * 檢查液溫感測器是否斷線。 * 如無斷線或接觸不良的現象，則液溫感測器或是溫度控制器故障。
	狀況排除	<ul style="list-style-type: none"> * 重新接線。 * 更換故障品。

(2)	訊號說明	室溫/機體溫度感測器異常警告。
Sn PV°C ro SV°C	可能原因	<ul style="list-style-type: none"> * 室溫/機體溫度感測器斷線或接觸不良。 * 溫度控制器故障。
	檢查方法	<ul style="list-style-type: none"> * 檢查室溫/機體溫度感測器是否斷線。 * 如無斷線或接觸不良的現象，則室溫/機體溫度感測器或是溫度控制器故障。
	狀況排除	<ul style="list-style-type: none"> * 重新接線。 * 更換故障品。

(3)	訊號說明	液溫過高異常警告。
AH PV°C OL SV°C	可能原因	<ul style="list-style-type: none"> * 液溫超過45°C。 * 冷卻機冷卻能力不足。 * 液溫感測器故障。 * 冷卻系統故障，冷媒阻塞或洩漏。
	檢查方法	<ul style="list-style-type: none"> * 檢查液溫或室溫是否超過45°C。 * 計算所需冷卻能力是否超過冷卻機之負載。 * 壓縮機低壓側的銅管不冷。 * 冷凝器之散熱片不熱。 * 乾燥劑表面溫度過低。 * 檢查液溫感測器是否正常。
	狀況排除	<ul style="list-style-type: none"> * 保持油溫於45°C以下。 * 更換比較大負載的冷卻機。 * 更換溫度感測器。 * 聯絡冷卻系統維修人員。



(4)	訊號說明	液溫/室溫過低異常警告。
AL PV°C OL SV°C	可能原因	<ul style="list-style-type: none"> * 液溫和室溫過低。 * 溫度控制器或液溫感測器故障。
	檢查方法	<ul style="list-style-type: none"> * 檢查液溫和室溫是否低於5°C。 * 檢查液溫感測器是否正常。 * 若以上正常，則溫度控制器故障。
	狀況排除	<ul style="list-style-type: none"> * 控制液溫於5°C以上，請注意冷卻機和機器應該一起啟動。 * 保持室溫於5°C以上。 * 更換故障品。

(5)	訊號說明	壓縮機表面溫度過高異常警告。
PV°C EF SV°C	可能原因	<ul style="list-style-type: none"> * 散熱不良。 * 輸入電壓錯誤。 * 壓縮機故障。
	檢查方法	<ul style="list-style-type: none"> * 檢查入氣孔和散熱孔是否阻塞。 * 檢查輸入電壓和其相性是否正確。 * 觀察壓縮機起始狀況，檢查其起始電壓。
	狀況排除	<ul style="list-style-type: none"> * 改善通風環境。 * 更正連線。 * 更換壞掉的壓縮機。

(6)	訊號說明	液位過低異常警告。
PV°C EL SV°C	可能原因	<ul style="list-style-type: none"> * 油箱內液位不足。 * 液位開關故障。
	檢查方法	<ul style="list-style-type: none"> * 檢查油箱內液位。 * 若確定油箱內有足夠的油，液位開關可能故障
	狀況排除	<ul style="list-style-type: none"> * 確定運轉時油箱和油路內有足夠的油。 * 更換故障的液位開關。

(7)	訊號說明	冷卻系統內壓力異常警告。
in PV°C -- SV°C -P- PRESSURE	可能原因	<ul style="list-style-type: none"> * 冷媒過多或不足。 * 冷卻系統阻塞或洩漏。 * 冷凝器或空氣濾網骯髒阻塞。 * 散熱不良。 * 風扇故障。
	檢查方法	<ul style="list-style-type: none"> * 壓縮機低壓側的銅管不冷。 * 冷凝器之散熱片不熱。 * 乾燥劑表面溫度過低。 * 檢查冷卻機內部溫度是否過熱。 * 風扇馬達是否故障。
	狀況排除	<ul style="list-style-type: none"> * 有關冷卻系統方面的故障，請聯絡冷卻系統維修人員。 * 定期清理冷凝器或空氣濾網以增加散熱效率，並移除通風口的阻塞物。

(8)	訊號說明	泵浦異常警告。
 PV°C -- SV°C  PUMP	可能原因	<ul style="list-style-type: none"> * 過載保護器跳脫。 * 軸承卡死或泵浦燒毀。 * 油路阻塞。
	檢查方法	<ul style="list-style-type: none"> * 檢查泵浦馬達是否正常運轉。 * 檢查軸承是否阻塞。 * 檢查油壓是否過大而使過載保護器跳脫。 * 檢查油管看油路是否阻塞。
	狀況排除	<ul style="list-style-type: none"> * 更換故障的泵浦。 * 降低壓力後復歸過載保護器。 * 清理油循環系統，若有必要可加裝油濾網。

(9)	訊號說明	壓縮機異常警告。
 PV°C -- SV°C  COMP	可能原因	<ul style="list-style-type: none"> * 電源電壓不正確。 * 壓縮機燒燬。 * 過載保護器跳脫。 * 散熱不良。 * 風扇故障。
	檢查方法	<ul style="list-style-type: none"> * 檢查電源電壓。 * 檢查壓縮機。 * 檢查過載保護器是否跳脫。 * 檢查冷卻機內部溫度是否過熱。 * 風扇馬達是否故障。
	狀況排除	<ul style="list-style-type: none"> * 更正為正確電壓。 * 更換壓縮機。 * 復歸過載保護器 * 提升工作環境，製造良好通風場所來減少週遭環境溫度。 * 更換風扇馬達。

(10)	訊號說明	油路內油壓或油量不足異常警告。
 PV°C -- SV°C  O.P./FLOW	可能原因	<ul style="list-style-type: none"> * 油路未循環或油量不足。 * 油壓減少。 * 油壓表或流量開關異常。 * 油路內有空氣。 * 泵浦故障。 * 油黏度過濃。
	檢查方法	<ul style="list-style-type: none"> * 檢查油路內和油箱內是否有足夠的油。 * 太長、過細、或壓扁的油管會造成油壓損失。 * 有時油壓開關的設定錯誤，請檢查其設定是否符合設計。 * 主軸卡筍損壞會造成泵浦故障使油路內無流量 * 油路內有空氣時會阻擋流量。 * 檢查使用的油黏度是否在適用範圍內。 * 若以上皆正常，則可能油壓開關或流量開關故障。
	狀況排除	<ul style="list-style-type: none"> * 補足油路和油箱內的油料。 * 縮短油管長度或加大其直徑。 * 調整壓力設定值。 * 更換故障泵浦。 * 請參考 3-1 運轉前檢查事項 排出油路內的空氣。 * 請使用適用油類。 * 更換故障的零件。

(11)	訊號說明	電源相性異常警告。
 PV°C -- SV°C  REV	可能原因	<ul style="list-style-type: none"> * 輸入之電源逆相。 * 來源電壓為單相。 * 逆相電驛或溫度控制器故障。
	檢查方法	<ul style="list-style-type: none"> * 檢查主電源。 * 檢查輸入的電源，其三相是否正確連接。 * 若電源連接正常，則可能逆相電驛或溫度控制器故障。
	狀況排除	<ul style="list-style-type: none"> * 更換主電源RST任兩條。 * 三相用的冷卻機須接三相電源。 * 更換逆相電驛或溫度控制器。

(12)	訊號說明	電源欠相警報。
	可能原因	* 電源S相欠相。
	檢查方法	<ul style="list-style-type: none"> * 檢查電源S相端子是否鬆脫。 * 若無鬆脫，則為控制器故障。
	狀況排除	<ul style="list-style-type: none"> * 若為電源S相鬆脫，則將S相固定確實。 * 若電源S相無鬆脫，則須更換控制器。

(13)	訊號說明	風扇馬達過電流。
EE	可能原因	* 過載保護器跳脫。 * 風扇馬達故障
	檢查方法	* 檢查過載保護器。 * 檢查風扇馬達是否故障。
	狀況排除	* 復歸過載保護器。 * 更換風扇馬達。

(14)	訊號說明	加熱器異常。
E4	可能原因	* 加熱器高溫保護開關動作。 * 高溫保護開關故障
	檢查方法	* 檢查冷卻液液位是否太低或循環液體沒有流動。 * 檢查高溫保護開關接點是否無輸出。
	狀況排除	* 添加冷卻液或檢查液體無流動原因並排除之。 * 更換高溫保護開關。

6-3 HB4異常訊號狀況排除

(1)	訊號說明	冷卻機異常。
Er	可能原因	* 電源逆相或逆相電驛故障。 * 泵浦馬達故障。 * 壓縮機馬達故障。
	狀況排除	* 更換任意兩相電源線或換新逆相電驛。 * 檢查或更換泵浦馬達。 * 檢查或更換壓縮機馬達。

(2)	訊號說明	液溫高於上限警報值。
RH	可能原因	* 冷媒系統洩漏或故障。 * 冷卻能力太小。 * 周圍溫度太高。 * 溫控器故障。
	狀況排除	* 檢測故障點修理之。 * 更換較大能力冷卻機。 * 保持環境溫度在40°C以下。 * 更換溫控器。

(3)	訊號說明	液溫低於下限警報值。
AL	可能原因	* 壓縮機無法停止。 * 溫度控制器或液溫感測器故障。
	狀況排除	* 檢查壓縮機控制迴路是否正常。 * 檢查液溫感測器是否正常。 * 若以上正常，則溫度控制器故障。

(4)	訊號說明	液溫感溫棒短路或故障。
E 1H	可能原因	* 液溫感溫棒或溫控器故障。
	狀況排除	* 更換液溫感溫棒或溫控器。

(5)	訊號說明	液溫感溫棒斷路或故障。
E 1L	可能原因	* 液溫感溫棒接線不良或溫控器故障。
	狀況排除	* 檢查液溫感溫棒接線或更換溫控器。

(6)	訊號說明	基礎溫感溫棒短路或故障。
E 2H	可能原因	* 基礎溫感溫棒或溫控器故障。
	狀況排除	* 更換基礎溫感溫棒或溫控器。

(7)	訊號說明	基礎溫感溫棒斷路或故障。
E 2L	可能原因	* 基礎溫感溫棒接線不良或溫控器故障。
	狀況排除	* 檢查基礎溫感溫棒接線或更換溫控器。

6-4 無異常訊號狀況排除

(1) 故障狀況：電源輸入但冷卻機和泵浦不運轉。

(A) 現象	PV°C, SV°C不顯示。	
可能原因	* 主電源連結不良或線路保護器跳脫。 * 控制板故障。 * 控制板之保險絲熔毀。	
檢查方法	* 檢查電源供電是否正常。 * 檢查電氣連結是否正常。 * 檢查保險絲。 * 若以上皆正常，則控制板可能故障。	
狀況排除	* 重新連結錯誤配線。 * 更換故障之零件。	

(B) 現象	PV°C, SV°C顯示溫度；PUMP運轉燈亮。	
可能原因	* 遠端遙控功能連結不良。 * 輸入錯誤電壓。	* 電磁開關故障。 * 馬達故障。
檢查方法	* 檢查遠端遙控連結是否正常。 * 檢查輸入電壓。	* 檢查電磁開關。 * 檢查馬達。
狀況排除	* 重新連結遠端遙控功能。 * 輸入正確電壓。 * 更換故障零件。	

(2) 故障狀況：泵浦運轉燈亮且泵浦運轉；油路異常。

(A) 現象	油流量減少，泵浦有異音。	
可能原因	* 管束未鎖緊。 * 油濾網阻塞。 * 油壓損失造成調壓閥動作。	* 油箱內油量不足。 * 油溫和黏度在適用範圍外。 * 油路內有空氣。
檢查方法	* 檢查管束。 * 檢查油濾網是否有異物阻塞。 * 檢查油壓是否正常。 * 檢查油箱內的油位是在指定範圍內。 * 油黏度適用範圍請參考圖6、油的黏度會因室溫變低而變高。 * 檢查油路內是否有空氣。	
狀況排除	* 鎖緊管束。 * 清潔油濾網。 * 增加油管直徑和縮短油管長度可避免油壓損失。 * 注油入油箱至指定範圍。 * 請使用適用油類。 * 移除油路內的空氣。請參考 3-1 運轉前檢查事項。 * 請參考P.9調整泵浦壓力。	

(3) 故障狀況：泵浦運轉正常；冷卻功能異常。

(A) 現象	冷卻系統不動作(壓縮機不運轉)。	
可能原因	* 當油溫到達設定值時，壓縮機停止運轉。 * 電磁開關異常。 * 散熱不良。	
檢查方法	* 檢查油溫是否到達設定值。 * 檢查冷卻機內部溫度。 * 檢查電磁開關。	
狀況排除	* 當油溫到達設定值時，壓縮機停止運轉屬正常現象。 * 更換故障的電磁開關。 * 提升工作環境，製造良好通風場所。	

(B) 現象	油溫到達指定溫度時，壓縮機不停止運轉。
可能原因	<ul style="list-style-type: none"> * 負載超過冷卻能力。 * 散熱不良。 * 冷媒洩漏。 * 溫度控制器故障。
檢查方法	<ul style="list-style-type: none"> * 檢查所需冷卻能力是否超過冷卻機之負載。 * 檢查冷卻機內部溫度是否過熱。 * 壓縮機低壓側的銅管不冷。 * 若以上皆正常，則溫度控制器可能故障。
狀況排除	<ul style="list-style-type: none"> * 更換冷卻能力比較大的冷卻機。 * 提升工作環境，製造良好通風場所來降低週遭環境溫度。 * 有關冷卻系統方面的故障，請聯絡冷卻系統維修人員。 * 更換溫度控制器。

(4) 故障狀況：正常運轉中突然停止；警報信號送出。

(A) 現象	PV°C和SV°C亮但不動作。
可能原因	<ul style="list-style-type: none"> * 工作母機振動使接線脫落。 * 遠端遙控功能接點脫落。 * 溫度控制器接點脫落或故障。
檢查方法	<ul style="list-style-type: none"> * 檢查各接點。 * 若各接點皆正常，則溫度控制器故障。
狀況排除	<ul style="list-style-type: none"> * 重新連結接點。 * 更換故障的溫度控制器。

(B) 現象	PV°C和SV°C不亮且不動作。
可能原因	<ul style="list-style-type: none"> * 迴路保護器跳脫。 * 工作母機振動使接線脫落。 * 遠端遙控功能接點脫落。 * 溫度控制器接點脫落或故障。 * 電源供應器故障。
檢查方法	<ul style="list-style-type: none"> * 檢查迴路保護器是否跳脫。 * 檢查各接點。 * 檢查電源供應器是否正常。 * 若以上皆正常，則溫度控制器可能故障。
狀況排除	<ul style="list-style-type: none"> * 復歸迴路保護器。 * 重新連結接點。 * 更換故障的溫度控制器。

1. General Safety Precaution

Some general safety precautions should always be taken when near the cooler unit. Study well and follow all of these instructions before attempting to operate the cooler unit in order to prevent the risk of fire, electric shock or personal injury.

- (1) Keep work area clean with sufficient light : dark and messy environments invite accidents.
- (2) Avoid dangerous environment : Do not locate the cooler unit at areas where it's damp or wet. Avoid exposing the cooler unit to rain or potential explosive environment.
- (3) Keep away from Children : All should keep a safety distance away from the cooler unit, except for the operating personnel.
- (4) Use appropriate power cord : Ensure to use cords that are in good conditions and are able to undertake the provided current.
- (5) Proper wearing : Avoid wearing loose clothing, necklets, rings, bracelets or other jewelry which may be caught by moving parts. It is recommended to wear non-slip footwear and protective hair covering for long hair when near the cooler unit.
- (6) Avoid stacking upon cooler unit : Do not stack anything on top of the cooler unit. It may cause personal injuries when items fall from the top.
- (7) Please disconnect the main power source of machine and cooling unit before connect/reconnect of electrical wires cooler unit and machine.
- (8) If there is any repairing or parts replacement required, please pay attention to the following instruction:
 - (A) Turn the operation switch and main power source OFF before proceeding any installation or repairing.
 - (B) If there is flame welding while repairing, please avoid flame near any oil (gas or liquid form) areas. It is advised to dismount the cooler from the oil tank; extract and wipe off any oil from the system completely.
 - (C) Choose a well-ventilated place when the release of refrigerant is required, to avoid the danger of suffocation.

2. Installation

This cooler unit is produced for cooling of hydraulic heat source, spindle lubrication/cooling system of machine tools or special purpose grinding machines. (Please refer to figure 1 for application.)

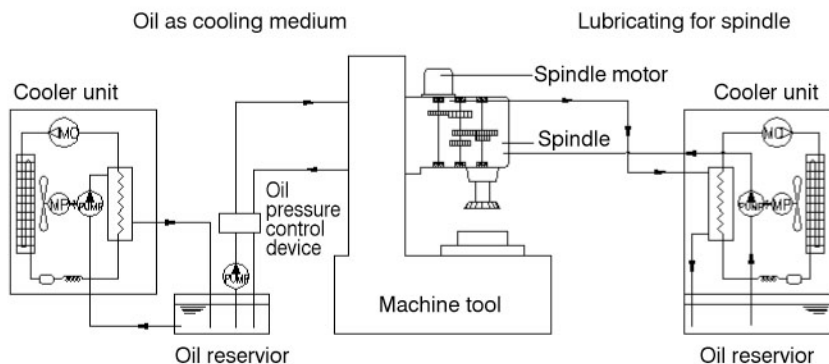

(fig. 1)

2-1 Transportation

- (1) Keep the cooler unit at upright position and avoid collision or shock during transportation. Do not incline, lay down or upside down the cooler unit.
- (2) When transporting or relocating the cooler unit, make sure to use correct tools such as hoist, freight elevator. Never move the cooler unit with bare hand.
- (3) Disconnect the power cord and discharge the oil within the cooler unit before relocation of the cooler unit.
- (4) While moving the cooler unit with a folk lifter, please make sure the cooler units are well-balanced and the cooler unit should not be lifted higher than 20 cm above the ground level. (Please refer to fig. 2)
- (5) Moving with a hoister :
 - (A) When moving the cooler unit with hoister, please choose the hoister and the rope which have sufficient strength to support the weight of the cooler units.
 - (B) Keep the cooler unit at upright position and well-balanced.
 - (C) While hoisting, all personnel must keep a safety distance from the hoist and the inner angle of wires should be kept less than 45° . (Please refer to fig.3)

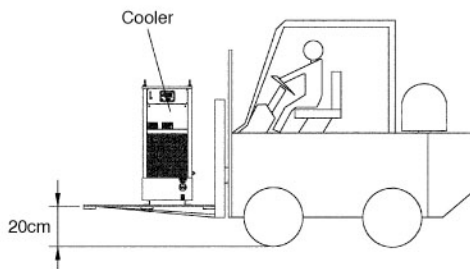

(fig. 2)

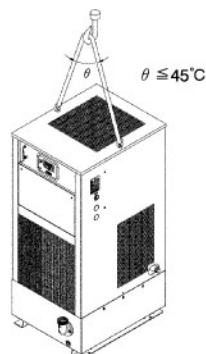

(fig. 3)

2-2 Location

- (1) Locate the cooler unit at clean environment.
- (2) Locate the cooler unit at well ventilated area.
- (3) Avoid the following locations :
 - * Environment with ambient or room temperature over 40°C.
 - * Areas where causes obstruction of air intake or exhaust vent.
 - * Environment with atmosphere containing corrosive or flammable dusts, oil mist, conductive powder (such as carbon or metal).
- (4) Please refer to fig 4 for the working temperature range.
- (5) The space required around the cooler unit is shown at fig. 5.

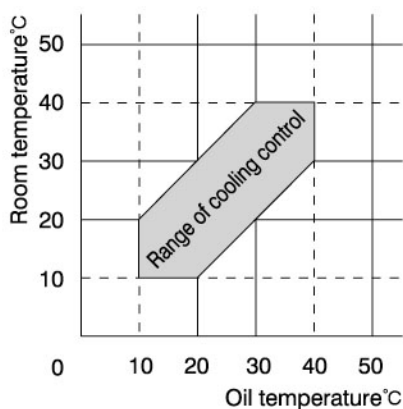

(fig. 4)

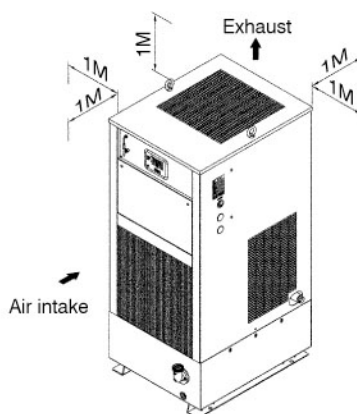

(fig. 5)

2-3 Acceptable Oil

- (1) This cooler unit accepts mineral hydraulic oil and lubrication oil; please do not use any of the following oil.
 - * Phosphate, chlorinated hydrocarbon, and fire resistant hydraulic oil such as water/glycol oil and W/O, O/W emulsion type hydraulic oil.
 - * Cutting oil, grinding oil, water soluble liquid.
 - * Food stuff, medicine and strongly corrosive liquid.
 - * Gasoline, kerosine and organic solvent.
- (2) The recommended oil Viscosity for this cooling unit is 4-300CST. When the oil viscosity is too high or the length of the oil pipe connected to the machine tools is too long, it will cause loss of oil pressure and irregular noise. To solve this problem, please shorten the length of oil pipes outside the cooler unit and change to oil with lower viscosity. (please refer to fig. 6 for acceptable range of oil viscosity)

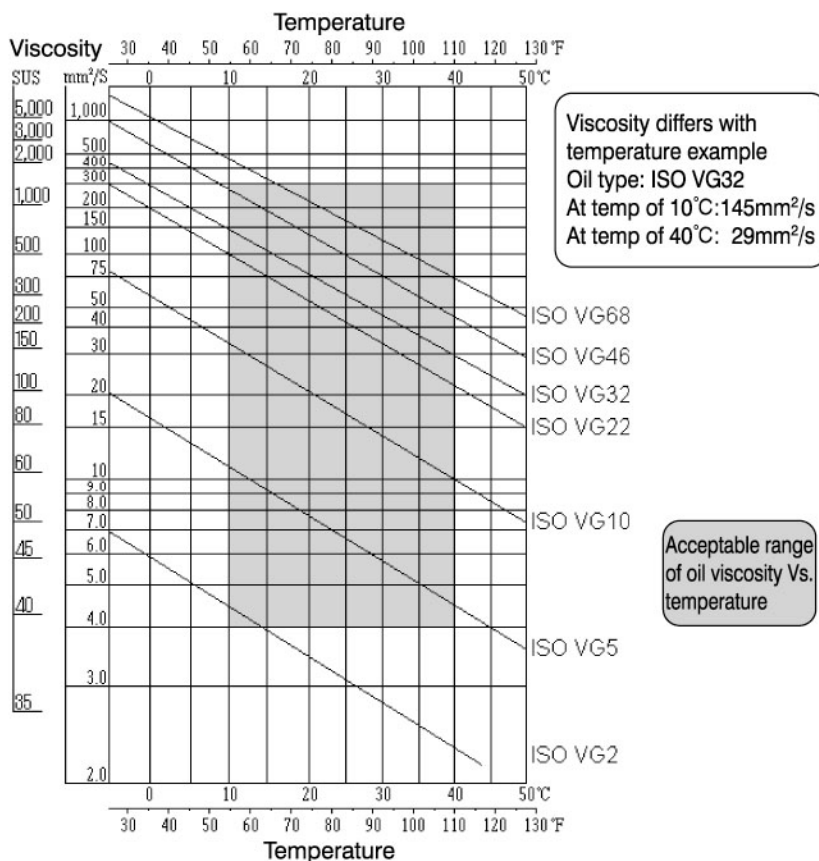

(fig. 6)

2-4 Oil Piping

- (1) Any oil pipes and connection parts for the connection between machine tools and the cooler unit are supplied by customers.
- (2) Please do not use rigid oil pipes. All oil pipes should be flexible type.
- (3) The oil pipes used must be capable for oil pressure over 142psi (10 kgf/cm²).
- (4) Please use dust free pipes to avoid mal-function of heat exchanger and pump.
Please install an oil filter with 100-150mesh at the inlet end of the oil circulating system.

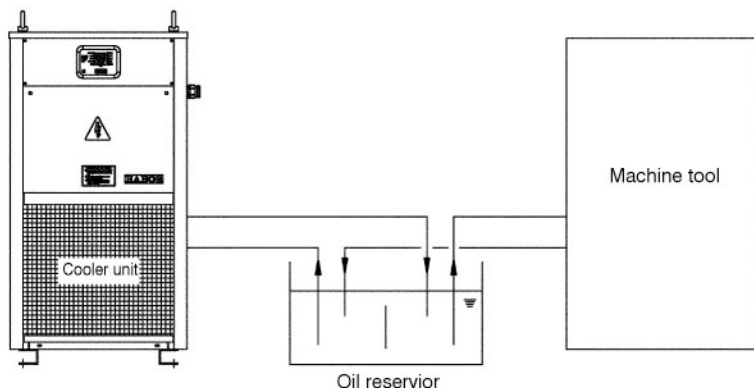

(fig. 7)

- (5) The pipes installed at external of the cooler unit shall not be thinner than the diameter of the inlet and outlet ends of the cooler unit. Use of seal tape is recommended to avoid leakage or air penetrated into the system. To avoid oil pressure loss or flow rate loss, shorten the oil pipe and use fewer valves.
- (6) Please refer to fig. 7 for ideal oil piping.
- (7) When the pump have created noises due to high pipe resistance or due to the higher oil viscosity from low ambient temperature, please refer to P.32 for the method of pump pressure change.

2-5 Electrical Wiring

- (1) Please take note on safety precaution before proceeding any wiring.
- (2) Any electric wiring should follow the electrical rules and should be done by qualified and certificated technician.
- (3) Please connect the wire according to the electrical circuit diagram.
- (4) Please make sure the grounding wire has been correctly connected. Do not connect the grounding wire to gas tube, lightning rod or grounding wire of phone set to avoid electrical shock.
- (5) It is necessary to install an electrical circuit breaker for the power source to avoid possible electrical shock or personal injury.
- (6) Remote control and alarm output connection :
 To remote control the cooler unit from the equipment ends, simply connect the signal cable to the RE1 and RE2 terminals at the cooler ends.
 To receive error signals from the machine tool end, please connect the signal cable to the 11 and 12 terminals.

3. Operating

3-1 Checklist before Operating

- * If the power voltage and phases inputted are correct.
- * If the oil pipe has been properly connected. Check if there's any leakage in the oil circulating system.
- * If the electric wiring has been properly connected, includes grounding connection.
- * If there's sufficient oil in the tank or in the system to operate, note that insufficient oil within the system will cause damage to the oil pump.
- * If the cooler has been properly located, good working environment with good ventilation and ambient temperature is within the operating range.
- * Note that frequent restart will damage the cooler unit. Please do not restart the cooler unit within the 3 minutes after it's been turned off.
- * There are chances of air penetrated into the oil circulating system, which will cause decrease in flow rate and noise within the system. To remove air in the oil circulating system :
 - (A) Input main power to the cooler unit, pump will then start operating.
 - (B) Slightly loose the oil pipe at oil outlet of the cooler unit to push the air out of the system and then tighten the pipe again.
 - (C) Switch off the power input.

3-2 Operating Control

(1) OTC Panel explanation

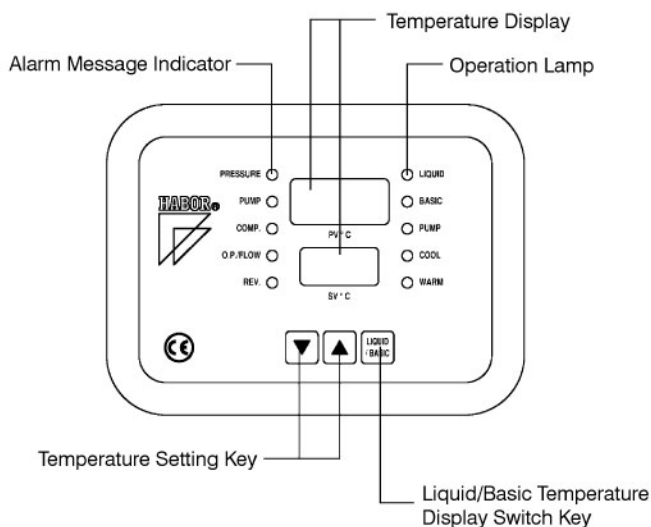

- (A) Temperature Display :
- PV°C : Displays the current oil temperature or the current ambient/machine body temperature. (See (4) for details)
 - SV°C : Displays the current temperature set value.
- (B) Operation Lamp :
- PUMP : Indicates if the pump starts operating.
 - COOL : Indicates if cooling process starts.
 - WARM : Indicates if heater (optional component) starts operating.
- (C) Temperature Setting Button :
- Set temperature by ▼▲ keys.
- (D) Liquid/Basic Temperature Display Switch :
- The value of PV°C display changes to ambient or machine body temperature when pressed; whilst the BASIC lamp is on. When release it, the LIQUID lamp is on and PV°C displays the temperature of the oil. (This function is disabled for the fixed temperature control models.)
- (E) Alarm Message Indicator :
- Should any error occur during operation; the cooler unit will stop and display error messages. Please refer to **6 -2 Trouble Shooting for OTC Alarm** for details.

Operation Instruction

Input power into the cooler unit, the value of PV°C and SV°C will be displayed; pump will start operating while the operation lamp of PUMP light.

The cooler unit will start the temperature control based on the set value (displayed in SV°C).

(A) Temperature control

- * For fixed temperature control models : While the power is ON. Whenever the value in the PV°C is higher than the set value (SV°C), the operation lamp COOL will be on and cooler unit starts the cooling process. If the temperature of the oil reaches SV°C or lower than SV°C, the COOL lamp will be off and the cooling process will stop.
- * For differential temperature control models : While the power is ON. If the set value (SV°C) is less than zero (-1 ~ -10), the operation lamp COOL will be on and cooler unit starts the cooling process. When the temperature difference between the oil and the ambient / machine body temperature reaches SV°C, the COOL lamp will be off and the cooling process will stop.

(B) Temperature setting range

- * Fixed temperature control : 10°C~40°C.
- * Differential temperature control : -10°C~+10°C.

(2) HB4 Controller

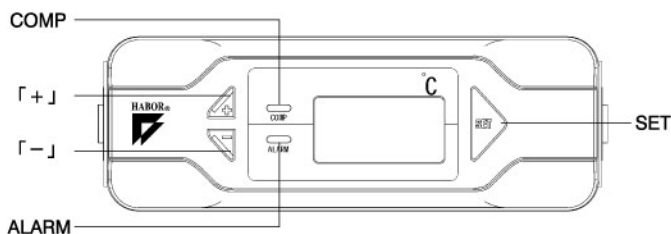

Operating instruction

- (A) Indicator display "888" when power input, then indicates the liquid temperature while the system starts operating.
- (B) Press 「SET」 and indicator flashes "888" 3 times and display "L5" (set value). Press 「SET」 again will activate the mode to set the temperature value; press 「▲」 「▼」 to set the temperature value.
- (C) To end the mode of setting temperature, press 「SET」 again, and indicator will firstly display "900" then display the liquid temperature.
- (D) If neither of the 「SET」 「▲」 「▼」 is pressed within the 30 seconds under the temperature setting mode; the system will automatically end the mode and return to display the temperature.
- (E) The COMP LED is on when compressor starts to operate (cooling process), it will flash when compressor is waiting to be started.
- (F) The ALARM LED will be on when there's some problem occurred, please refer to the above table.
- (G) To view the base temperature value, please press 「+」 .
- (H) To view the set value, please press 「-」 .
- (I) Should any error occur during operation, please refer to **6.3 Trouble Shooting for HB4 Alarm**.

4. Maintenance

Please take note on the safety precaution before proceed.

For the cooler unit to perform at its best cooling capacity and to extend its life-time, regular maintenance is required. After all, in order to keep the cooler at its best condition, the cooler required a well-ventilated, obstruction-free environment.

4-1 Cleaning

Please switch off the main power before proceeding any maintenance or cleaning (includes removing the air filters). Removing any components during operation may cause serious injury to personnel or even damage the cooler.

List of components that required cleaning regularly :

- * Cooler body.
- * Condenser.
- * Air filter.
- * Oil filter.
- * Oil tank.

Please check below for detailed cleaning procedures.

(1) Cooler body

- (A) Clean the surface of cooling unit with neutral detergent or qualified soap. Do not use hot water, steel-brush, polishing powder or any acidic solvents to prevent any damages to the painted surface.
- (B) Clean cooler body : when cleaning the internal area of the cooler, please avoid water for electric components.
- (C) Please use dry materials to wipe any electrical components.

(2) Condenser

Please check the condenser if it is clogged with contaminants. Use Compressed air or long brush to remove the dust from condenser.

(3) Air Filter

- (A) To remove the filter, please lift up the filter to draw out (fig.12).
- (B) Please use a vacuum cleaner, compressed air, water and brush to clean the filter. Allow the filter to dry after cleaning before installing back onto the machine. Clean the filter regularly at least once every fortnight and it is recommended to clean the filter whenever it's heavily stained.

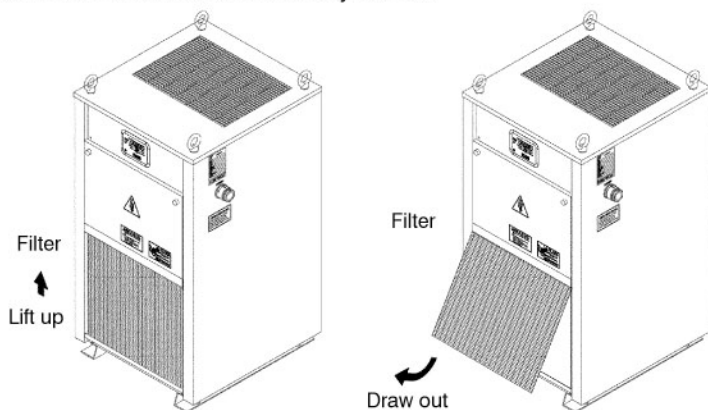

(4) Oil filter

Clean the oil filter once a day in the early stage after piping and then every two to four days after normal operation.

(5) Oil tank

If the cooler is located in humid climate zone, eventually there will be water formed within the tank and sink at the bottom. Please drain out the water from the tank at least once a month.

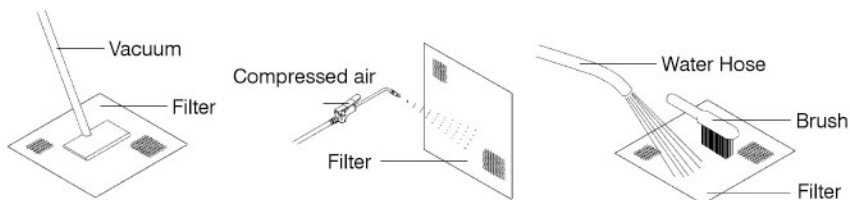

4-2 Storage

Basically, protection of the interior components and condenser against dust and moisture are things to take note for long term storage.

- (1) Please store the cooler at dust free area.
- (2) Wipe the power cable clean before storing.
- (3) Please use cover to prevent dust and moisture.
- (4) Please store the cooler unit at flat ground with dry and cool environment.
- (5) If the cooler unit is assembled with carter wheels, please lock up the wheels to hold the cooler unit at position. Unlocked wheels may cause the cooler unit to move when unattended which may cause serious injuries to personnel and damage to the cooler unit if collided.

5. Adjusting the pump pressure

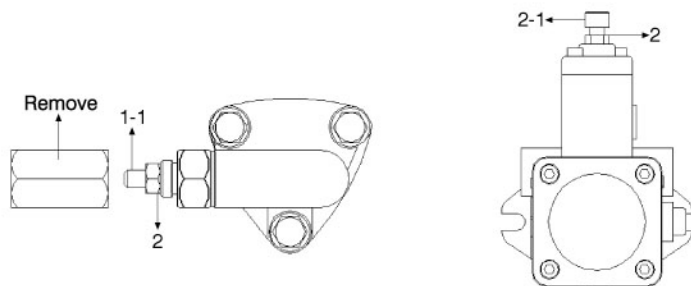

The pump will create noise due to difference of piping or change of oil viscosity, please adjust pump output pressure to solve the noise problem. Please refer to the above figures according to the models used.

Please note, adjusting the pump output pressure will result changes of flow rate and pressure, Please double check the adjusted flow rate and pressure is suitable for the application, and it is recommend to double check by the flow meter or pressure gauge.

- (A) Loosen screw nut 2, while holding 1-1 or 2-1.
- (B) If there is loud noise from the pump, turn 1-1 or 2-1 in the direction of anti-clockwise will release the pressure, please adjust according to application of the cooler.
- (C) If the flow rate is not enough from the pump, turn 1-1 or 2-1 in the direction of clockwise will increase the pressure, please adjust according to application of the cooler.
- (D) After adjustment, tighten screw nut 2 while holding the setted position of 1-1 or 2-1.

6. Trouble Shooting

Please take note on the safety precaution before proceed any repairing. Please also note that all the inspections and repairing should be done by qualified professional technicians. When any errors or abnormal conditions occurred in the system, the cooler will stop and send out signals, please refer to this section, remove the errors then restart the cooler.

6-1 Leakage

Leaks from the oil hose can be fixed with tighten the tube clip or even replacements. When welding tools are necessary for repairing :

- (1) Choose a well ventilated area to avoid suffocation due to the release of the refrigerant.
- (2) Please extract all oil out of the cooler unit and disconnect all oil pipes between machine tools and cooler unit to avoid fire hazard.
- (3) Please extract refrigerant out of the cooler unit according to the relevant law/ regulation of environmental protection.

6-2 Trouble Shooting for OTC Alarm



(1)	Explanation	Oil temperature sensor fault.
Sn PV°C OL SV°C	Possible Cause	* Broken connection of the oil temperature sensor. * Oil temperature sensor fault. * Temperature controller failure.
	Inspection	* Check if the connection of the oil temperature sensor is broken * If the connection is not broken, then there are chances of temperature controller failure or sensor failure.
	Solution	* Reconnect the wire connection, or replace the wire if necessary. * Replace the failure parts.



(2)	Explanation	There is a problem with the ambient or machine body temperature sensor.
Sn PV°C ro SV°C	Possible Cause	* The wire connection of the ambient or machine body temperature sensor is broken. * The ambient or machine body temperature sensor failure. * The temperature controller failure.
	Inspection	* Check if the wire for ambient or machine body temperature sensor still connected. * If there are no problems with the connection, chances are either the sensor or the temperature controller is faulty.
	Solution	* Reconnect the wire connection, or replace the wire if necessary. * Replace the failure parts.



(3)	Explanation	Oil temperature is too high for the cooler to process.
AH PV°C OL SV°C	Possible Cause	<ul style="list-style-type: none"> * Process load over the limit of the cooler unit's capacity. * Oil temperature sensor failure. * Refrigeration system failure.
	Inspection	<ul style="list-style-type: none"> * Check if the ambient and oil temperatures are higher than the limit of 45°C. * Check if the cooler unit is capable for the process load. * The copper pipe near the low pressure side of the compressor is not cold. * Fins of condenser are not hot. * The temperature of the dryer is lower than exhaust heat.
	Solution	<ul style="list-style-type: none"> * Check if the sensor functions properly. * Keep the oil temperature below 45°C. * Change cooler unit to a larger cooling capacity. * Replace the oil temperature sensor. * Contact the refrigeration technician for refrigeration system failures.

(4)	Explanation	Oil/Ambient temperature is too low the cooler to process.
AL PV°C OL SV°C	Possible Cause	<ul style="list-style-type: none"> * Oil temperature is too low. * Ambient temperature is too low. * Temperature controller failure. * Oil/Ambient temperature sensor fault.
	Inspection	<ul style="list-style-type: none"> * Check if the oil temperature and the ambient temperature are above 5°C. * Check if the temperature sensor functions properly. * If the above seems to be order, then the temperature controller failed.
	Solution	<ul style="list-style-type: none"> * Control the oil temperature above 5°C, note that the cooler unit and the machine tools should start simultaneously. * Keep the ambient above 5°C. * Replace faulty parts.

(5)	Explanation	Surface temperature of the compressor is too high.
PV°C EF SV°C	Possible Cause	<ul style="list-style-type: none"> * Poor heat dissipation. * Incorrect power voltage input. * Faulty compressor.
	Inspection	<ul style="list-style-type: none"> * Check if any air vent is cloggy. * Check the input power if it's correct voltage and phase. * Check the starting condition of the compressor, measure the starting voltage.
	Solution	<ul style="list-style-type: none"> * Create better heat dissipation environment. * Reconnect the wires for correct power input. * Replace faulty compressor.
(6)	Explanation	Liquid level in the oil tank is too low.
PV°C EL SV°C	Possible Cause	<ul style="list-style-type: none"> * Not enough oil in the oil tank. * Oil level switch fault.
	Inspection	<ul style="list-style-type: none"> * Check if the oil level in the oil tank is sufficient. * If the oil within the tank is enough, chances are oil level switch fails.
	Solution	<ul style="list-style-type: none"> * Make sure the oil within the oil circulating system is sufficient. * Replace the faulty oil level switch.
(7)	Explanation	There is a pressure fault within the refrigeration system.
In PV°C -- SV°C -P- PRESSURE	Possible Cause	<ul style="list-style-type: none"> * Low or over charge of refrigerant. * Obstruction/leakage occurred in the refrigeration system. * Condenser/air filter are dirty or cloggy. * Poor heat dissipation. * Fan failure.
	Inspection	<ul style="list-style-type: none"> * The copper pipe near the low pressure side of the compressor is not cold. * Fins of condenser are not hot. * The temperature of the dryer is lower than exhaust heat. * Check if cooler unit's internal temperature is too high. * Check if the air intake or exhaust is cloggy. * Check if the air filter or the condenser is dirty. * Check if fan out of order.
	Solution	<ul style="list-style-type: none"> * Please contact the refrigeration service technician for faults within the refrigeration system. * Clean the air filter and the condenser regularly to improve the heat dissipation, and remove any obstructers from air intake or exhaust. * Replace faulty parts.

(8)	Explanation	There is a fault within the pump which trip out the overload protector.
 PV°C -- SV°C  PUMP	Possible Cause	<ul style="list-style-type: none"> * Trip-out in overload protector. * Poor insulating or a burn out pump. * The temperature controller failure.
	Inspection	<ul style="list-style-type: none"> * Check if the pump motor still operates. * Check if the bearing is cloggy. * Check if the oil pressure is too high to cause the overload protector to trip-out. * Check the liquid pipe if the liquid flow is smooth.
	Solution	<ul style="list-style-type: none"> * Replace faulty pump. * Reset the overload protector after unload of the oil pressure. * Clean the liquid circulating system, add a filter if necessary.

(9)	Explanation	There is a fault within the compressor which trip out the overload protector.
 PV°C -- SV°C  COMP	Possible Cause	<ul style="list-style-type: none"> * Incorrect power voltage input. * Compressor has burned out. * Overload protector trip out. * Poor heat dissipation. * Fan failure.
	Inspection	<ul style="list-style-type: none"> * Check if the input power voltage is correct. * Check if the compressor has burned out. * Check if the overload protector has trip out. * Check if cooler unit's internal temperature is too high. * Fan is out of order.
	Solution	<ul style="list-style-type: none"> * Input the correct power voltage. * Replace burned out compressor. * Reset the overload protector. * Improve the working environment to lower ambient temperature and create better ventilation. * Replace fan.

(10)	Explanation	There is an oil pressure fault or insufficient oil amount within the oil circulating system.
  O.P./FLOW	Possible Cause	<ul style="list-style-type: none"> * No liquid flow or insufficient oil. * Oil pressure loss. * Oil pressure switch or flow rate switch failure. * Air penetrated into oil circulating system. * Pump motor failure. * Oil viscosity is too high.
	Inspection	<ul style="list-style-type: none"> * Check if there's enough oil within the oil circulating system. * Long, thin and flattened oil hoses will cause oil pressure loss. * Please check if the value of oil pressure switch is within the designed specification. * If the pump motor fails, there will be no oil flow, sometimes it's the worn out of key. * Check if there's any air penetrated into the oil circulating system. * Check if the oil used is within the viscosity range. * If all the above is alright, there's a chance of failure in oil pressure switch or the flow rate switch.
	Solution	<ul style="list-style-type: none"> * Supply more oil into the oil tank or the oil circulation system to the rated level. * Increase the diameter of the hose or shorten the length of hose to avoid oil pressure loss. * Reset the oil pressure switch to designed specification. * Replace faulty pump motor. * For air penetrated into the oil circulating system, please refer to 3-1 Checklist before operating. * Use oil with lower viscosity. * Replace faulty parts.

(11)	Explanation	The power phase input has been reversed.
	Possible Cause	<ul style="list-style-type: none"> * Reversed phase of main power source. * Power source is single- phased. * Reverse-phase relay failure. * Temperature controller failure.
	Inspection	<ul style="list-style-type: none"> * Check if the power phase input is correct. * If the power phase is correct, it's whether the reverse-phase relay or the temperature controller has failed.
	Solution	<ul style="list-style-type: none"> * Reconnect the power cable with correct phase. * Three phase cooling unit should be connected to three phase power source. * Replace the faulty parts.

(12)	Explanation	Power phase missing Alarm
	Possible Cause	<ul style="list-style-type: none"> * The S power phase from 3 phases R, S, T is missing.
	Inspection	<ul style="list-style-type: none"> * Check if the S power phase is connected properly. * If the phase is connected properly, then the controller has failed.
	Solution	<ul style="list-style-type: none"> * RE-fix the S power phase connection. * Replace the possible failure controller.

(13)	Explanation	Fan motor overloaded
	Possible Cause	<ul style="list-style-type: none"> * The overload protector of the fan motor have tripped out. * Fan motor failure.
	Inspection	<ul style="list-style-type: none"> * Reset the overload protector to check if this is from sudden overload. * Check if the fan motor has failed.
	Solution	<ul style="list-style-type: none"> * Reset the overload protector. * Replace the fan motor.

(14)	Explanation	Abnormal heater operation.
	Possible Cause	<ul style="list-style-type: none"> * The overheating protection of heater activated. * Fake alarm from overheating protection.
	Inspection	<ul style="list-style-type: none"> * Check if there are sufficient cooling liquid within the system or if there are any liquid flow. * Check the output contact of the overheating protection.
	Solution	<ul style="list-style-type: none"> * Refill the cooling liquid and examine the problem of flow. * Replace the overheating protector.

6-3 Trouble Shooting for HB4 Alarm

(1)	Explanation	Cooler Failure
Er	Possible Cause	<ul style="list-style-type: none"> * The power input is reversed or the reversal relay failure. * Failure of pump motor. * Failure of compressor.
	Solution	<ul style="list-style-type: none"> * Change any two line of R,S,T or replace the reversed. * Examine or replace the pump motor. * Examine or replace the compressor.

(2)	Explanation	Liquid temperature is over the limitation to proceed.
AH	Possible Cause	<ul style="list-style-type: none"> * Leakage or fault within the refrigeration system. * Not enough cooling capacity. * High ambient temperature causes poor heat dissipation. * Thermostat failure.
	Solution	<ul style="list-style-type: none"> * Examine and repair the refrigeration system. * Change the cooler to bigger capacity. * Improve the working environment to reduce the temperature to lower than 40°C. * Replace a new thermostat.

(3)	Explanation	Liquid temperature is below the limitation to proceed.
AL	Possible Cause	<ul style="list-style-type: none"> * Compressor cannot be stopped. * Failure of temperature controller or the liquid temperature sensor.
	Solution	<ul style="list-style-type: none"> * Check the control circuit of the compressor. * Check if the liquid temperature sensor is function. * If the aboves function properly, then the temperature connection.

(4)	Explanation	Liquid temperature sensor failure
E IH	Possible Cause	* Liquid temperature sensor or thermostat failure.
	Solution	* Replace faulty sensor or thermostat.

(5)	Explanation	Connection failure of liquid temperature sensor
E IL	Possible Cause	* Liquid temperature sensor connection failure or thermostat failure.
	Solution	* Reconnect the sensor or replace faulty thermostat.

(6)	Explanation	Base temperature sensor failure
E2H	Possible Cause	* Base temperature sensor or thermostat failure.
	Solution	* Replace faulty sensor or thermostat.

(7)	Explanation	Connect on failure of base temperature sensor
E2L	Possible Cause	* Base temperature sensor connection failure or thermostat failure.
	Solution	* Reconnect the sensor or replace faulty thermostat.

6-4 Trouble Shooting without Alarm

(1) Situation: Main power inputed, cooling unit and pump will not run.

(A) Status	PV°C, SV°C will not display on the control panel.	
Possible Cause	<ul style="list-style-type: none"> * The main power may not be properly connected, or the circuit breaker of the main power source is at off position. * Control circuit board failure. * Fuse of the control circuit has blown. 	
Inspection	<ul style="list-style-type: none"> * Check if the main power source is supplying the power properly. (if the Circuit breaker is ON) * Check if the connection wire is connected properly. * Check if the fuse on the control circuit. * If all above seems to be in order, then it means a failure controller board. 	
Solution	<ul style="list-style-type: none"> * Reconnect the main power source. * Replace the blown fuse. * Replace the controller board. 	

(B) Status	PV°C, SV°C displays temperature; operation lamp PUMP on.	
Possible Cause	<ul style="list-style-type: none"> * Remote control function is not properly connected. * Power voltage input is incorrect. * Electromagnetic switch faults. * Motor failure. 	
Inspection	<ul style="list-style-type: none"> * Check the remote control connection. * Check if the power voltage that inputs into the motor is correct. * Check if the electromagnetic switch is in order. * Check if the motor still working properly. 	
Solution	<ul style="list-style-type: none"> * Reconnect the remote control function. * The power voltage inputs into motor should be the same as the rated power voltage for cooler unit. * Replace the faulty parts. 	

(2) Situation: Pump is operating while the operation lamp PUMP is on; but there's abnormal condition with oil circulating system.

(A) Status	Oil flow rate is reducing and noise is created at pump.
Possible Cause	<ul style="list-style-type: none"> * The tub clip of the oil pipe is not properly tightened. * Cloggy oil filter. * The activated of oil pressure regulating valve due to oil pressure loss. * Insufficient oil within the oil tank. * Oil temperature and viscosity are not within the operating range. * Air penetrated into the oil circulating system.
Inspection	<ul style="list-style-type: none"> * Loosening tub clip normally causes leakage in the system from the joints of hoses; please check if there's any leakage. * Check if the oil filter is clogged by contaminants. * Check if there's any oil pressure loss. * Check if the oil level within the tank is within the rated height. * Please refer to fig. 6 for acceptable range of oil viscosity, the oil viscosity will increase while ambient temperature decrease, and it will cause noises from the oil pump. * Check if there's any air penetrated into the oil circulating system.
Solution	<ul style="list-style-type: none"> * Tighten the loose tub clip. * Clean the oil filter. * Increase the diameter and shorten the length of the oil hoses to avoid pressure loss. * Fill in more oil into the tank. * Please use appropriate oil. * Remove the air within the oil circulating system. * Please refer to P.26 to adjust pump pressure.

(3) Situation: Pump is operating, but there's abnormal condition with the refrigerating system.

(A) Status	No cooling is processed. (I.e. compressor does not operate.)
Possible Cause	<ul style="list-style-type: none"> * The compressor will stop operating when the temperature of the oil has met the set value (SV°C). * Electromagnetic switch failure. * Poor heat dissipation.
Inspection	<ul style="list-style-type: none"> * Check if the oil temperature has met the required cooling range. * Check if the electromagnetic switch is in order. * Check if cooler unit's internal temperature is too high.
Solution	<ul style="list-style-type: none"> * It is normal for the compressor to stop operating when the oil temperature has met the set value. * Replace the electromagnetic switch. * Improve the working environment to lower ambient temperature and create better ventilation.

(B) Status	Cooling continues even set value is met.
Possible Cause	<ul style="list-style-type: none"> * The process load is over the limit of cooler unit's capacity. * Poor heat dissipation. * Leakage of refrigerant. * Thermostat failure
Inspection	<ul style="list-style-type: none"> * Check if the capacity of the cooler unit is suitable for the process load. * Check if cooler unit's internal temperature is too high. * The copper pipe near the low pressure side of the compressor is not cold. * If all seems to be in order, then thermostat fails.
Solution	<ul style="list-style-type: none"> * A larger capacity cooler unit is required. * Improve the working environment to lower ambient temperature and create better ventilation. * Contact the refrigeration service technician. * Replace thermostat.

(4) Situation: Sudden stop of the cooler while operating and an alarm signal sent to the machine tool.

(A) Status	PV°C and SV°C display properly.
Possible Cause	<ul style="list-style-type: none"> * The vibration of the machine tool will loose the connection wires. * Remote control connection is out. * Temperature controller connection is out * Temperature controller failure.
Inspection	<ul style="list-style-type: none"> * Check the connections of the remote control and the temperature controller. * If the connections are in order, then the temperature controller is faulty.
Solution	<ul style="list-style-type: none"> * Re-connect the connections. * Replace the temperature controller.

(B) Status	PV°C and SV°C does not display.
Possible Cause	<ul style="list-style-type: none"> * Circuit breaker of the cooler unit may have jumped. * The vibration of the machine tool will loose the connection wires. * The Remote control connection is out. * Thermostat connection is out. * Failure of thermostat. * Failure of power supplier.
Inspection	<ul style="list-style-type: none"> * Check if the circuit breaker is trip-out * Check the connections of the remote control and the thermostat. * Check if the power supplier still functions properly. * If all above seems to be in order, then the thermostat is fault.
Solution	<ul style="list-style-type: none"> * Reset the circuit breaker back on. * Reconnect the wires of the remote control and the thermostat. * Replace the faulty parts.



ISO 9001

主要產品系列：

- * 工具機專用油冷卻機系列
- * 放電加工機專用油冷卻機系列
- * 線切割加工機、印刷機、雷射加工切割機、
專用精密溫度控制循環式液體用冷卻機系列
- * 多用途冷凍式壓縮空氣乾燥機
- * 多用途除溼乾燥機
- * NC控制箱、電機、電力箱密閉式防塵、
防濕、冷卻專用熱交換冷卻器系列
- * NC控制箱密閉式空調冷卻機系列
- * 油壓箱冷卻專用熱管熱交換器

MAIN PRODUCTS SERIES:

- * Oil cooler series specific for machine tools
- * Oil cooler series specific for E.D.M.
- * The accurate temperature controller
refrigerated recirculating liquid Chillers for
wire cut E.D.M. printing machine & laser
cutting machine
- * Refrigerated compressor air dryer
- * Dehumidifier
- * Dust-proof, ash-proof enclosed heat
exchanger series specific for NC control
cabinet, & electric power cabinet etc.
- * Enclosed air conditioner series for NC control
cabinet
- * Heat pipe heat exchanger for oil cooling

哈伯精密工業有限公司

HABOR PRECISE INDUSTRIES CO., LTD.

411 台中縣太平市工業20路77號

NO.77, INDUSTRIAL 20TH ROAD,

TAI-PING CITY, TAICHUNG COUNTY 411, TAIWAN.

TEL: +886-4-2271-3588 FAX: +886-4-2271-3535

<http://www.habor.com> E-mail: habor@ms17.hinet.net

歡迎洽詢，型錄備索 Inquiries will be welcome & catalogues will also be provided.