

Side 高壓鼓風機 Channel Blower



DG DARGANG

峰緯機械有限公司

DAR GANG MACHINERY CORP.

公司簡介 Company Introduction

本公司為原台灣瑞昶電機有限公司技術及生產製造團隊所成立的新公司，並以  DARGANG 品牌行銷世界各地，本公司在製造高壓鼓風機的領域上已有二十幾年之經驗，秉持著服務至上、品質第一和技術本位的精神，來服務國內外產業界，希望舊雨新知繼續支持與指教。

本公司以全新模組製造出更高品質的鼓風機，無論在外觀、風壓及風量之特性上均比以往卓越，出廠前每台均經過嚴格測試，確保百分百高品質，以提供客戶更高效率的品質、更優質的服務以及更多元的選擇，協助客戶生產，更有市場競爭力的產品，並以協助國內外機械廠商，提升產品品質降低成本為目的。

We have a profession technical and manufacturing team formed originally from [Ruey Chaang Electric Co.,Ltd. \(CRELEC\)](#) and has been selling brand word-wide. The company has  DARGANG more than twenty years of high-pressure blower field experience with spirit of providing quick service and technical based high quality products for our most valuable customers and potential business partners. Your interests and enquires are always welcome.

A brand new set of modules have been invented to upgrade quality of our high-pressure blowers leading the new series of blowers are both in appearance, air pressure and volume more desirable than the old series. Rigorous tests and inspections have conducted for each blower ship out of the factory for firm 100% high quality products deliver to customers. The purpose is to make sure customers receive most efficient, higher quality service and muti-choice of products that will support local and global machinery manufacturers to upgrade their product quality and minimize cost.

鼓風機構造 Side Channel Blower Construction

外側軸承 *External bearing*

散熱良好 *Cool-running*

運轉壽命長 *Long life*

油封 *Shaft Seal*

使用免保養的軸封保護馬達，將馬達與鼓風機本體隔離。

Motor protected by maintenance-free shaft seal

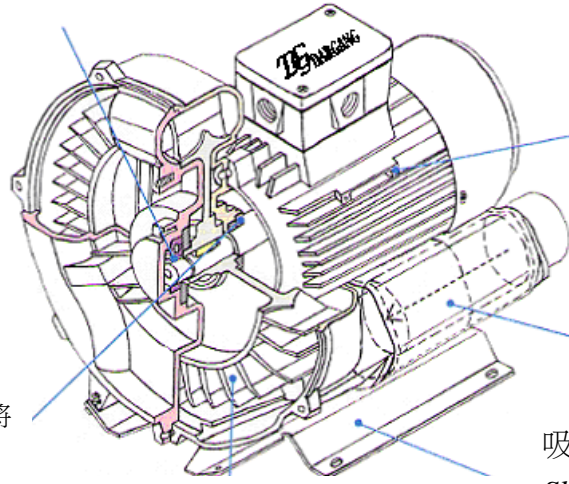

使用高效率的鋁合金風葉
High-efficiency die-cast impellers for all types

馬達 *Motor*

工業用 50/60Hz，鼠籠式馬達
全密 F 級，IP55

Industrial quality 50/60Hz Squirrel-cage motor totally enclosed (IP55) with F class insulation

消音器 *Silencer*

內藏式消音管 *Built-in silencer*

吸震式固定底座

Shock-absorbing mounting plate

鼓風機特性 Side Channel Blower Specific

安裝容易

可隨時安裝與使用，供壓縮空氣或用於抽真空，亦可任意安裝於水平或垂直的方向。

Easy to install

The blower is a complete unit ready for immediate installation either as a vacuum pump or as a compressor. The unit can be mounted in any position, horizontally or vertically.

結構堅固，可靠性高

鼓風機與馬達外殼分開壓鑄，皆用鋁合金精密壓鑄成型，堅固耐用。除了風葉之外，鼓風機沒有其他動件，因此可靠性高幾乎免維修。

Rugged, the cast for the impeller and the motor are individual to be made by aluminum. The blower has the highly-developed design which results in a pump construction with one moving part, a feature ensuring maximum operating reliability. Maintenance free!

無污染

風葉旋轉時，不與任何部分零件接觸，免潤滑，無油氣無污染。

No oily odors

The impeller rotates with absolutely no contact between it and the housing. This means no lubrication is required, guaranteeing 100% oil-free operation.

低噪音低震動

一體式的消音設施，低噪音馬達直接運轉，風葉均經過電腦平衡校正與高精密的機械加工，使震動及噪音降到最低。

Low Noise and Vibration

The use of direct-driving low-noise motors and integral silencers ensure a low noise level. Dynamic balancing minimizes vibration.

最高品質

精密機械設計，專業製造經驗，每一台鼓風機在出廠前均經過嚴格測試。

High Efficiency

Under serious QC control, the parts used in DG blower are of top quality. All blowers are made by professional technicians.



單相馬達 / Single Phase AC IP55 50Hz/60Hz

型號 Model	曲線編號 Curve No.	頻率 Frequency (Hz)	功率 Output (kW)	電壓 Voltage (V)	滿載額定電流 Current (A)	靜壓 吸 Vacuum / 吐 Compressor (mbar)	最大風量 Max Airflow (m ³ /min)	噪音 Noise (dB)A	重量 Weight (Kg)
DG-100-11	D1	50	0.18	100-120/200-240	2.50/1.25	50/40	1.0	52	6.5
	G1	60	0.2	110-120/220-240	2.55/1.28	70/70	1.2	55	
DG-200-11	D2	50	0.4	100-120/200-240	5.80/2.90	110/130	1.5	58	11.5
	G2	60	0.5	110-120/220-240	7.80/3.90	130/150	1.8	61	
DG-200-11W	D3	50	0.4	100-120/200-240	5.80/2.90	110/130	1.5	58	12
	G3	60	0.5	110-120/220-240	7.80/3.90	130/150	1.8	61	
DG-300-11	D4	50	0.75	100-120/200-240	11.6/5.80	140/150	2.6	63	16
	G4	60	0.85	110-120/220-240	13.0/6.50	140/140	3.1	64	
DG-300-11W	D5	50	0.75	100-120/200-240	11.6/5.80	140/150	2.5	63	16.5
	G5	60	0.85	110-120/220-240	13.0/6.50	140/140	3.1	64	
DG-300-31	D6	50	1.1	100-120/200-240	14.6/7.30	160/190	2.6	63	16.5
	G6	60	1.3	110-120/220-240	16.6/8.30	180/190	3.1	64	
DG-400-21	D7	50	1.1	100-120/200-240	17.0/8.50	150/150	3.7	70	23.5
	G7	60	1.3	110-120/220-240	19.0/9.60	150/140	4.4	73	
DG-400-31	D8	50	1.5	100-120/200-240	20.0/10.0	180/190	3.7	70	26
	G8	60	1.75	110-120/220-240	22.8/11.4	180/170	4.4	73	
DG-400-31W	D9	50	1.5	100-120/200-240	20.0/10.0	180/190	3.7	70	26.5
	G9	60	1.75	110-120/220-240	22.8/11.4	180/170	4.4	73	
DG-230-11	D10	50	0.75	100-120/200-240	9.20/4.50	180/220	1.6	60	17.5
	G10	60	0.85	110-120/220-240	11.0/5.40	200/220	1.8	66	
DG-330-11	D11	50	1.5	100-120/200-240	20.0/10.0	240/250	2.6	66	28.5
	G11	60	1.75	110-120/220-240	22.8/11.4	250/260	3.1	69	

- 附註：1.上述資料供參考，如有不同以實品為主。
 2.本公司保有設計變更之權利，恕不另行通知。
 3.如有任何疑問請洽經銷商或本公司。

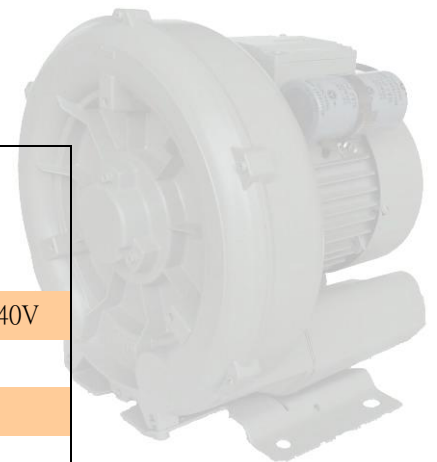

型號說明 Description of model
DG- <u>XXX</u> -xx 系列代號 / Series number

DG-xxx- <u>Xx</u> 代表各系列中功率大小排序 The sort of output in each series
--

DG-xxx-x <u>X</u> 代表電壓 / Voltage Code
--

電壓代碼 Voltages Code	50Hz	60Hz
0 :	1~ 100-120V	110-120V
1 :	1~ 100-120/200-240V	110-120/220-240V
2 :	1~ 185-220V	200-240V
3 :	1~ 200-220V	220-240V
4 :	3~ 200-240VΔ	200-240VΔ
5 :	3~ 185-225Δ /320-390Y	200-240Δ /345-415Y
6 :	3~ 200-240Δ /345-415Y	220-275Δ /380-480Y
7 :	特殊電壓	
8 :	3~ 345-415Δ /600-720Y	380-480Δ /660-830Y
9 :	3~ 400-460Δ /690-790Y	415-500Δ /720-860Y

DG-xxx-xxW	耐水氣及吸熱風型 Waterproof
B	低風壓 Low Pressure
L	左盒 Terminal box on the left
R	右盒 Terminal box on the right

吸/Vacuum

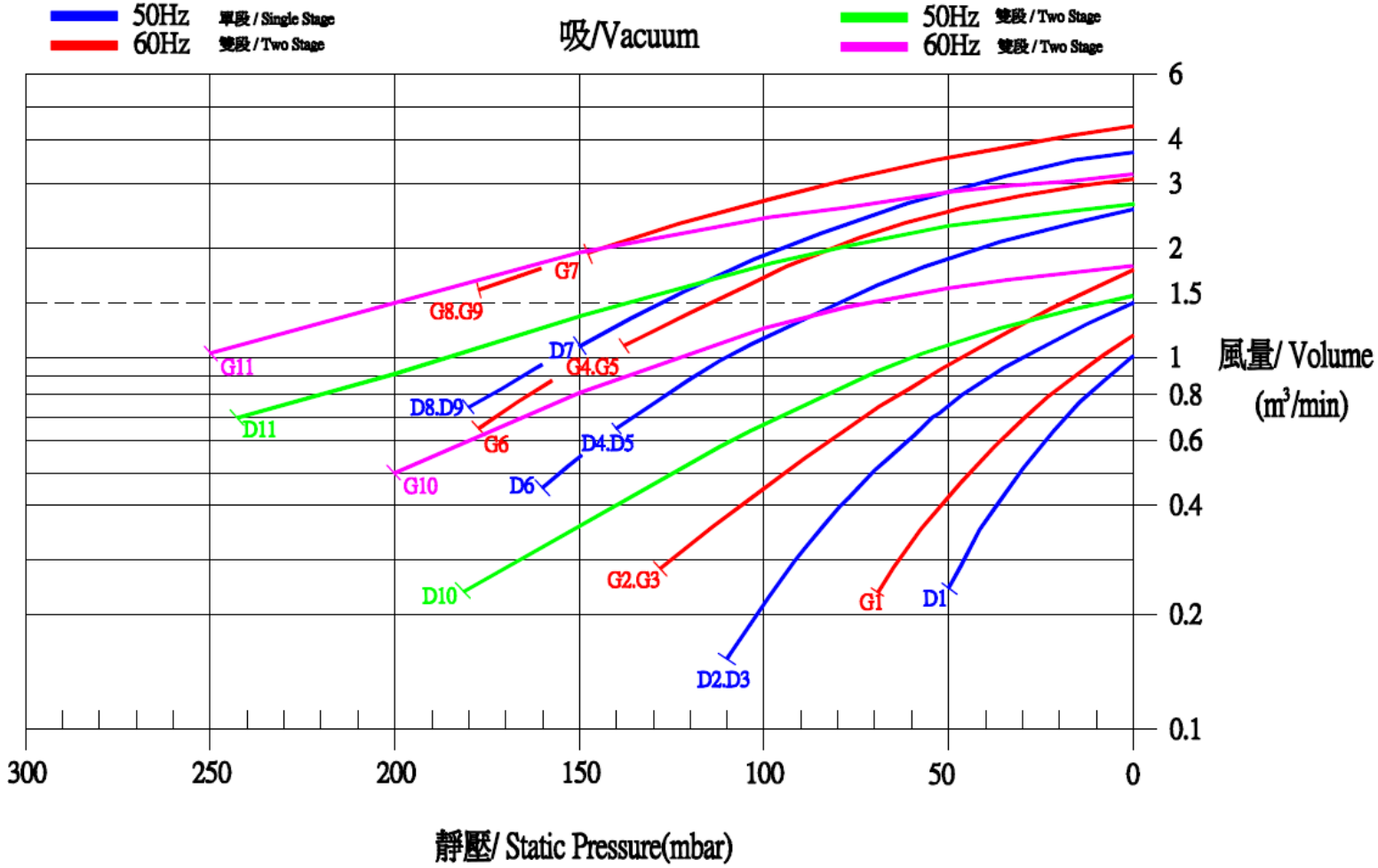

吐/Compressor

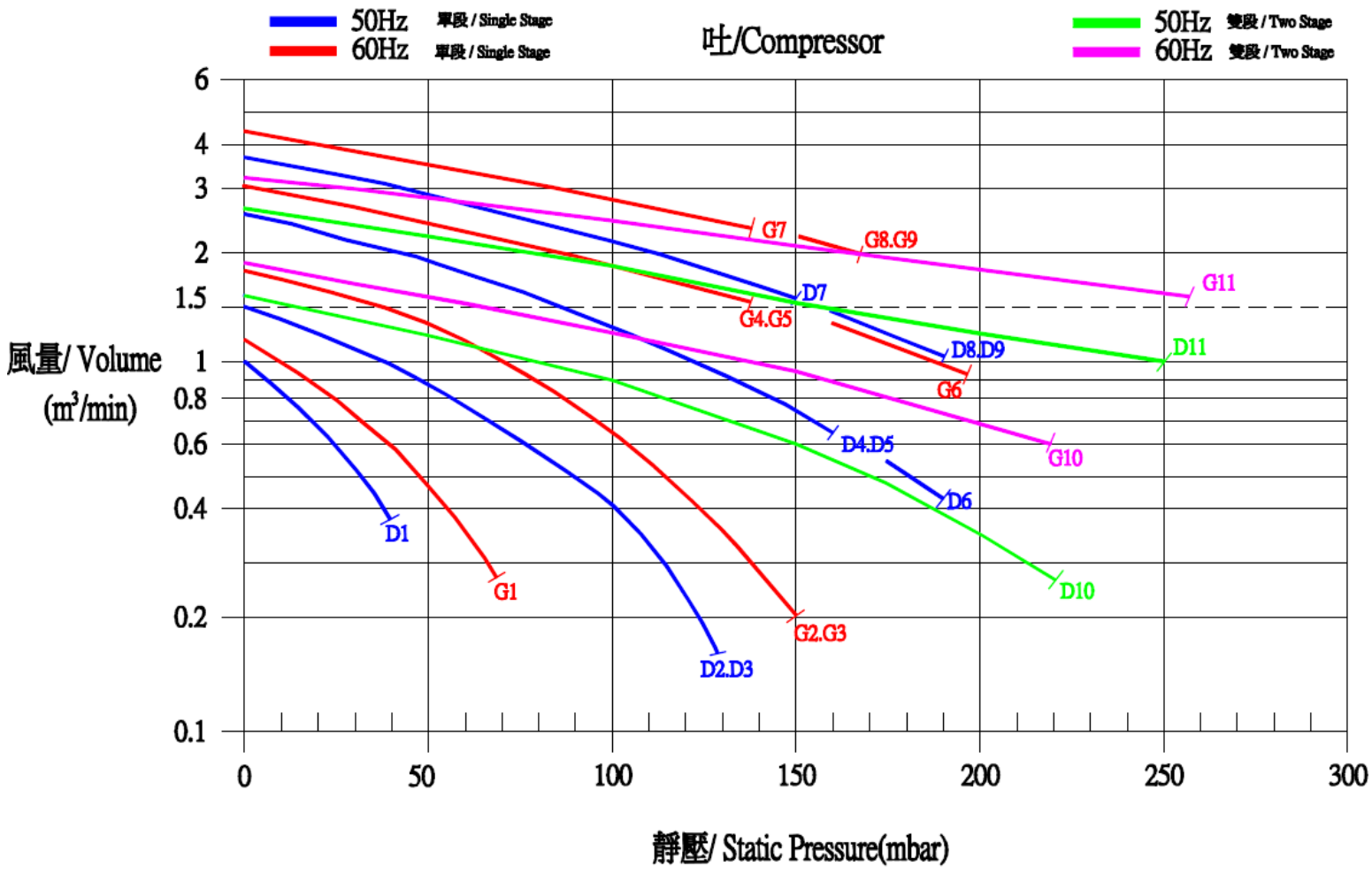

三相馬達 / Three Phase AC IP55 50Hz

型號 Model	曲線編號 Curve	頻率 Frequency (Hz)	功率 Output (kW)	電壓 Voltage (V)	滿載額定電流 Current (A)	靜壓 Static pressure Vacuum / Compressor (mbar)	最大風量 Max Airflow (m ³ /min)	噪音 Noise (dB)A	重量 Weight (Kg)
DG-100-16	D12	50	0.18	200-240Δ/345-415Y	1.20Δ /0.69Y	50/60	1	52	6.5
DG-200-16	D13	50	0.4	200-240Δ/345-415Y	2.20Δ/1.30Y	110/130	1.5	58	10.5
DG-200-16W	D14	50	0.4	200-240Δ/345-415Y	2.20Δ/1.30Y	100/130	1.5	58	11
DG-300-16	D15	50	0.75	200-240Δ/345-415Y	3.70Δ/2.14Y	140/140	2.6	63	14
DG-300-26	D16	50	0.9	200-240Δ/345-415Y	4.20Δ/2.40Y	165/180	2.6	63	15
DG-300-16B	D17	50	0.75	200-240Δ/345-415Y	3.70Δ/2.14Y	110/120	2.6	63	14
DG-300-16W	D18	50	0.75	200-240Δ/345-415Y	3.70Δ/2.14Y	140/140	2.6	63	14.5
DG-300-36	D19	50	1.3	200-240Δ/345-415Y	4.60Δ/2.65Y	175/200	2.6	63	16
DG-400-16	D20	50	0.9	200-240Δ/345-415Y	4.20Δ/2.40Y	130/120	3.7	70	20.5
DG-400-26	D21	50	1.3	200-240Δ/345-415Y	5.70Δ/3.30Y	180/180	3.7	70	22
DG-400-36	D22	50	1.75	200-240Δ/345-415Y	6.70Δ/3.90Y	210/220	3.7	70	23
DG-400-36B	D23	50	1.75	200-240Δ/345-415Y	6.70Δ/3.90Y	140/160	3.7	70	23
DG-400-36W	D24	50	1.75	200-240Δ/345-415Y	6.70Δ/3.90Y	210/220	3.7	70	23.5
DG-400-46	D25	50	2.2	200-240Δ/345-415Y	7.80Δ/4.50Y	220/270	3.7	70	26
DG-600-16	D26	50	2.2	200-240Δ/345-415Y	9.70Δ/5.60Y	220/210	5.5	72	32
DG-600-16B	D27	50	2.2	200-240Δ/345-415Y	9.70Δ/5.60Y	160/200	5.5	72	32
DG-600-16W	D28	50	2.2	200-240Δ/345-415Y	9.70Δ/5.60Y	220/210	5.5	72	32.5
DG-600-26	D29	50	3.4	200-240Δ/345-415Y	12.5Δ/7.20Y	255/270	5.5	72	34
DG-600-26W	D30	50	3.4	200-240Δ/345-415Y	12.5Δ/7.20Y	255/270	5.5	72	35.5
DG-600-36	D31	50	4	200-240Δ/345-415Y	14.3Δ/8.20Y	270/320	5.5	72	37
DG-800-16	D32	50	5.5	200-240Δ/345-415Y	25.3Δ/14.6Y	270/290	9.5	74	77
DG-800-26	D33	50	7.5	200-240Δ/345-415Y	31.5Δ/18.2Y	295/390	9.5	74	88
DG-900-16	D34	50	9	200-240Δ/345-415Y	36.0Δ/20.8Y	200/190	18.9	76	100
DG-900-26	D35	50	13	200-240Δ/345-415Y	46.8Δ/27.0Y	290/270	18.9	76	112
DG-900-36	D36	50	20	200-240Δ/345-415Y	66.7Δ/38.6Y	350/440	18.9	76	159
DG-230-16	D37	50	0.75	200-240Δ/345-415Y	3.70Δ/2.14Y	200/240	1.6	60	17
DG-330-16	D38	50	1.75	200-240Δ/345-415Y	6.70Δ/3.90Y	275/300	2.6	66	25
DG-330-26	D39	50	2.2	200-240Δ/345-415Y	7.80Δ/4.50Y	320/390	2.6	66	28
DG-430-16	D40	50	3.4	200-240Δ/345-415Y	12.5Δ/7.20Y	345/410	3.7	74	40
DG-430-26	D41	50	4	200-240Δ/345-415Y	14.3Δ/8.20Y	355/460	3.7	74	43
DG-630-26	D42	50	4	200-240Δ/345-415Y	14.3Δ/8.2Y	350/350	5.5	75	55
DG-630-36	D43	50	5.5	200-240Δ/345-415Y	21.6Δ/12.5Y	410/500	5.5	75	72
DG-630-46	D44	50	7.5	200-240Δ/345-415Y	31.5Δ/18.2Y	420/580	5.5	75	82
DG-640-36	D45	50	5.5	200-240Δ/345-415Y	25.3Δ/14.6Y	200/220	7.9	75	72
DG-640-46	D46	50	7.5	200-240Δ/345-415Y	31.5Δ/18.2Y	240/275	7.9	75	82
DG-830-16	D47	50	7.5	200-240Δ/345-415Y	31.5Δ/18.2Y	350/350	9.5	76	112
DG-830-26	D48	50	13	200-240Δ/345-415Y	46.8Δ/27.0Y	430/600	9.5	76	142
DG-830-36	D49	50	20	200-240Δ/345-415Y	66.7Δ/38.6Y	450/700	9.6	76	160
DG-840-16	D50	50	7.5	200-240Δ/345-415Y	31.5Δ/18.2Y	180/145	14.2	76	110
DG-840-26	D51	50	13	200-240Δ/345-415Y	46.8Δ/27.0Y	250/250	14.2	76	140
DG-840-36	D52	50	20	200-240Δ/345-415Y	66.7Δ/38.6Y	300/300	14.2	76	160

附註/Remark：1.上述資料供參考，如有不同以實品為主。

Information above is for reference, product only when different.

2.本公司保有設計變更之權利，恕不另行通知。

We reserve the right to change the design without notice.

3.如有任何疑問請洽經銷商或本公司。

Should you require any further information or assistance, please do not hesitate to contact us or distributors.



— 單段 / Single Stage

— 雙段 / Two Stage

50Hz(吸 / Vacuum)

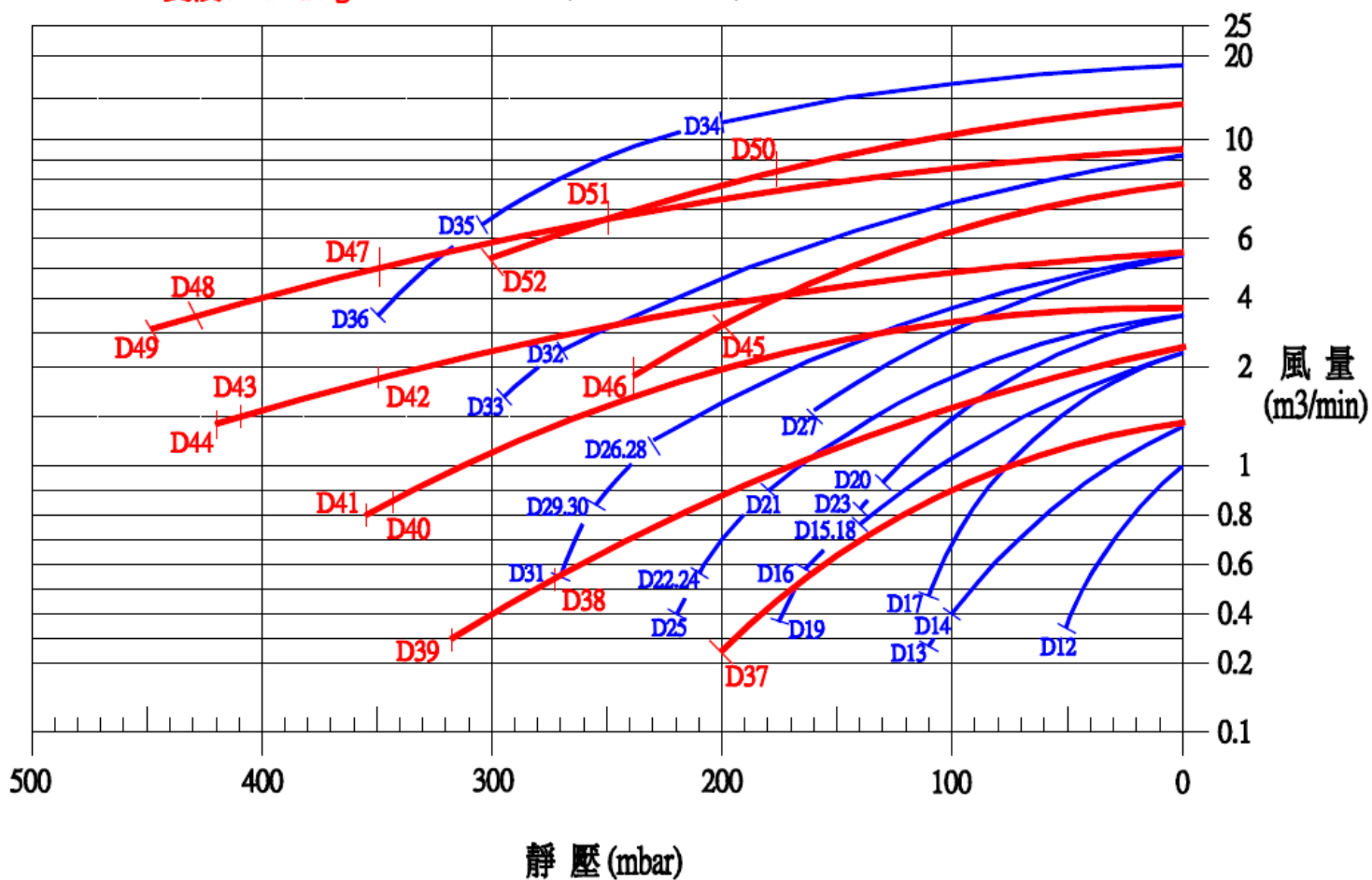

— 單段 / Single Stage

— 雙段 / Two Stage

50Hz(吐 / Compressor)

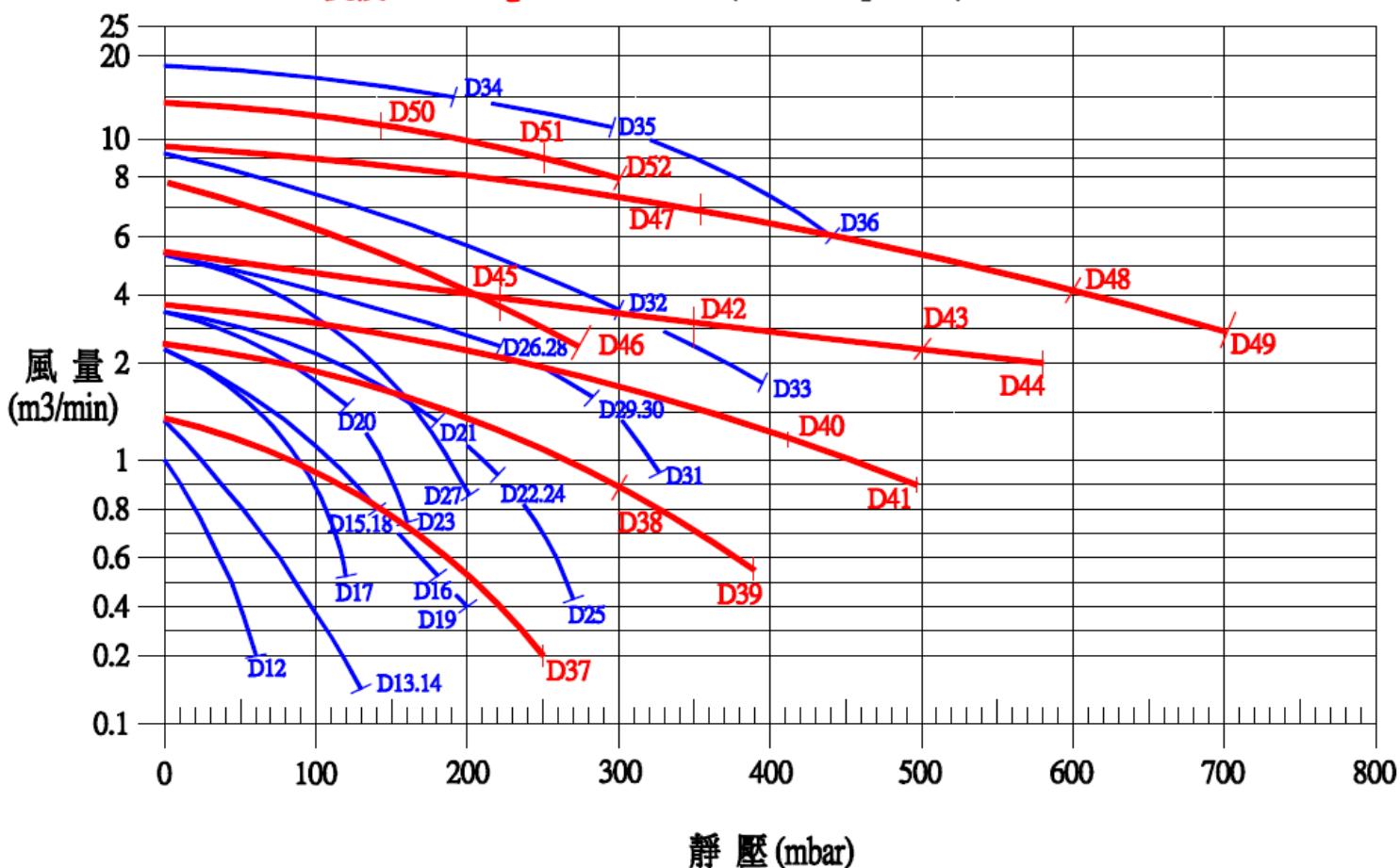

三相馬達 / Three Phase AC IP55 60Hz

型號 Model	曲線編號 Curve	頻率 Frequency (Hz)	功率 Output (kW)	電壓 Voltage (V)	滿載額定電流 Current (A)	靜壓 Static pressure Vacuum / Compressor (mbar)	最大風量 Max Airflow (m ³ /min)	噪音 Noise (dB)A	重量 Weight (Kg)
DG-100-16	G12	60	0.2	220-275Δ/380-480Y	0.90Δ /0.50Y	70/70	1.2	55	6.5
DG-200-16	G13	60	0.5	220-275Δ/380-480Y	2.30Δ/1.30Y	140/160	1.8	61	11
DG-200-16W	G14	60	0.5	220-275Δ/380-480Y	2.30Δ/1.30Y	140/150	1.8	61	11.5
DG-300-16	G15	60	0.85	220-275Δ/380-480Y	3.90Δ/2.25Y	140/140	3.1	64	14
DG-300-26	G16	60	1.1	220-275Δ/380-480Y	4.50Δ/2.60Y	180/180	3.1	64	15
DG-300-16B	G17	60	0.85	220-275Δ/380-480Y	3.60Δ/2.10Y	140/140	3.1	64	14
DG-300-16W	G18	60	0.85	220-275Δ/380-480Y	3.90Δ/2.25Y	140/140	3.1	64	14.5
DG-300-36	G19	60	1.5	220-275Δ/380-480Y	5.25Δ/3.00Y	205/230	3.1	64	16
DG-400-16	G20	60	1.1	220-275Δ/380-480Y	4.50Δ/2.60Y	120/110	4.4	73	20.5
DG-400-26	G21	60	1.5	220-275Δ/380-480Y	6.00Δ/3.50Y	170/160	4.4	73	22
DG-400-36	G22	60	1.9	220-275Δ/380-480Y	7.00Δ/4.00Y	200/200	4.4	73	23
DG-400-36B	G23	60	1.9	220-275Δ/380-480Y	7.00Δ/4.00Y	160/180	4.4	73	23
DG-400-36W	G24	60	1.9	220-275Δ/380-480Y	7.00Δ/4.00Y	200/200	4.4	73	23.5
DG-400-46	G25	60	2.6	220-275Δ/380-480Y	9.50Δ/5.50Y	255/290	4.4	73	26
DG-600-16	G26	60	2.6	220-275Δ/380-480Y	10.7Δ/6.20Y	220/200	6.5	77	32
DG-600-16B	G27	60	2.6	220-275Δ/380-480Y	10.7Δ/6.20Y	195/200	6.5	77	32
DG-600-16W	G28	60	2.6	220-275Δ/380-480Y	10.7Δ/6.20Y	220/200	6.5	77	32.5
DG-600-26	G29	60	3.7	220-275Δ/380-480Y	13.5Δ/7.80Y	280/270	6.5	77	34
DG-600-26W	G30	60	3.7	220-275Δ/380-480Y	13.5Δ/7.80Y	280/270	6.5	77	35.5
DG-600-36	G31	60	4.6	220-275Δ/380-480Y	16.2Δ/9.30Y	315/320	6.5	77	37
DG-800-16	G32	60	6.3	220-275Δ/380-480Y	29.5Δ/17.0Y	290/270	11.3	79	77
DG-800-26	G33	60	8.6	220-275Δ/380-480Y	37.0Δ/21.3Y	350/395	11.3	79	88
DG-900-16	G34	60	11	220-275Δ/380-480Y	37.0Δ/21.4Y	180/170	22.4	81	100
DG-900-26	G35	60	15	220-275Δ/380-480Y	51.5Δ/29.8Y	280/270	22.4	81	112
DG-900-36	G36	60	22	220-275Δ/380-480Y	76.0Δ/44.0Y	365/420	22.4	81	159
DG-230-16	G37	60	0.85	220-275Δ/380-480Y	3.90Δ/2.25Y	245/245	1.8	67	17
DG-330-16	G38	60	1.9	220-275Δ/380-480Y	7.00Δ/4.00Y	300/300	3.1	69	25
DG-330-26	G39	60	2.6	220-275Δ/380-480Y	9.50Δ/5.50Y	350/420	3.1	69	28
DG-430-16	G40	60	3.7	220-275Δ/380-480Y	13.5Δ/7.80Y	370/350	4.4	77	40
DG-430-26	G41	60	4.6	220-275Δ/380-480Y	16.2Δ/9.30Y	410/475	4.4	77	43
DG-630-26	G42	60	4.6	220-275Δ/380-480Y	16.2Δ/9.3Y	350/350	6.5	79	55
DG-630-36	G43	60	6.3	220-275Δ/380-480Y	26.5Δ/13.5Y	420/500	6.5	79	72
DG-630-46	G44	60	8.6	220-275Δ/380-480Y	37.0Δ/21.3Y	450/675	6.5	79	82
DG-640-36	G45	60	6.3	220-275Δ/380-480Y	29.5Δ/17.0Y	180/170	9.5	79	72
DG-640-46	G46	60	8.6	220-275Δ/380-480Y	37.0Δ/21.3Y	260/260	9.5	79	82
DG-830-16	G47	60	8.6	220-275Δ/380-480Y	37.0Δ/21.3Y	290/290	11.3	81	112
DG-830-26	G48	60	15	220-275Δ/380-480Y	52.0Δ/30.0Y	450/600	11.3	81	142
DG-830-36	G49	60	22	220-275Δ/380-480Y	76.0Δ/44.0Y	470/780	11.3	81	160
DG-840-16	G50	60	8.6	220-275Δ/380-480Y	37.0Δ/21.3Y	110/110	16.5	81	110
DG-840-26	G51	60	15	220-275Δ/380-480Y	52.0Δ/30.0Y	230/200	16.5	81	140
DG-840-36	G52	60	22	220-275Δ/380-480Y	76.0Δ/44.0Y	300/280	16.5	81	160

附註/Remark：1.上述資料供參考，如有不同以實品為主。

Information above is for reference, product only when different.

2.本公司保有設計變更之權利，恕不另行通知。

We reserve the right to change the design without notice.

3.如有任何疑問請洽經銷商或本公司。

Should you require any further information or assistance, please do not hesitate to contact us or distributors.

— 單段 / Single Stage

— 雙段 / Two Stage

60Hz(吸 / Vacuum)

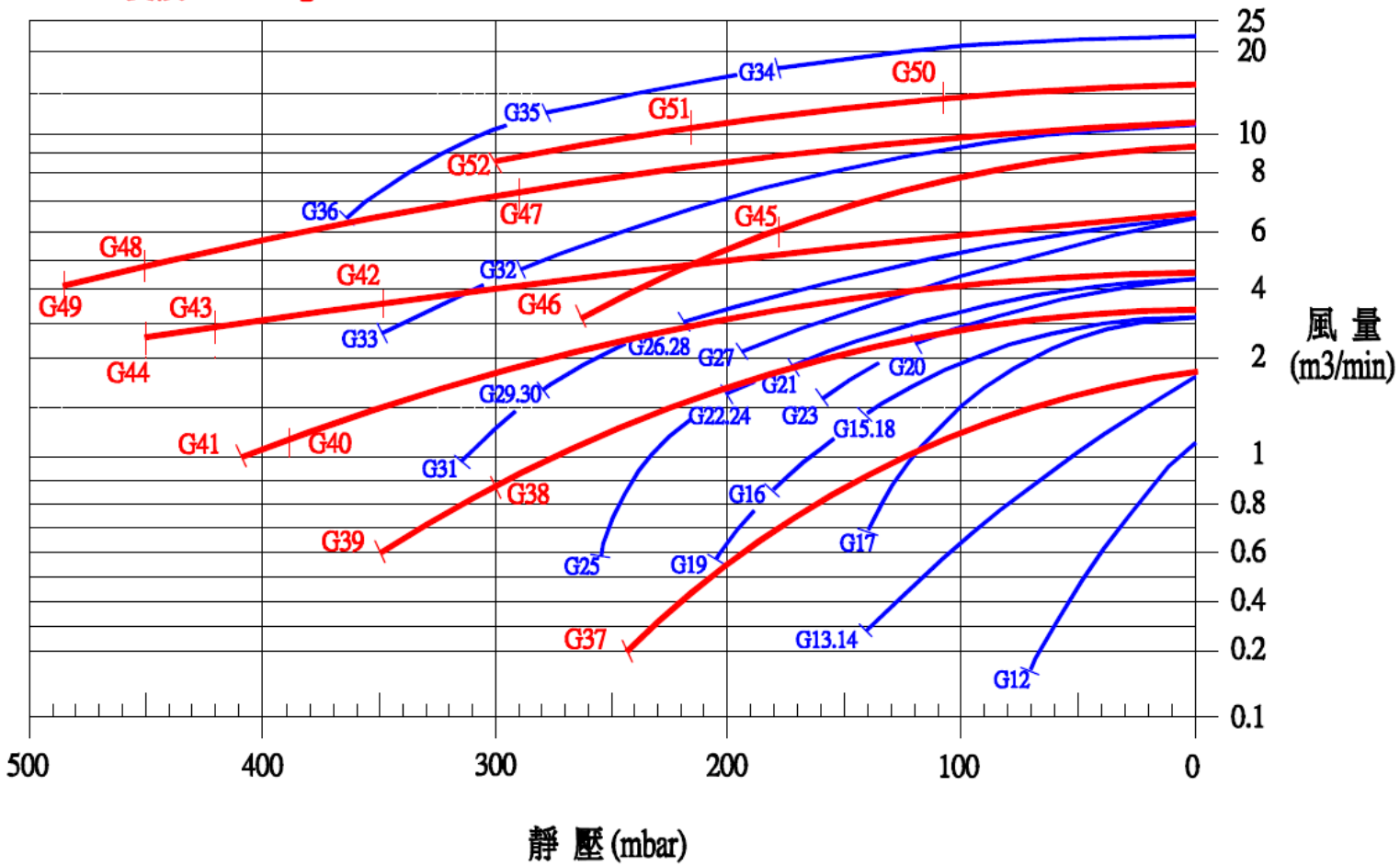

— 單段 / Single Stage

— 雙段 / Two Stage

60Hz(吐 / Compressor)

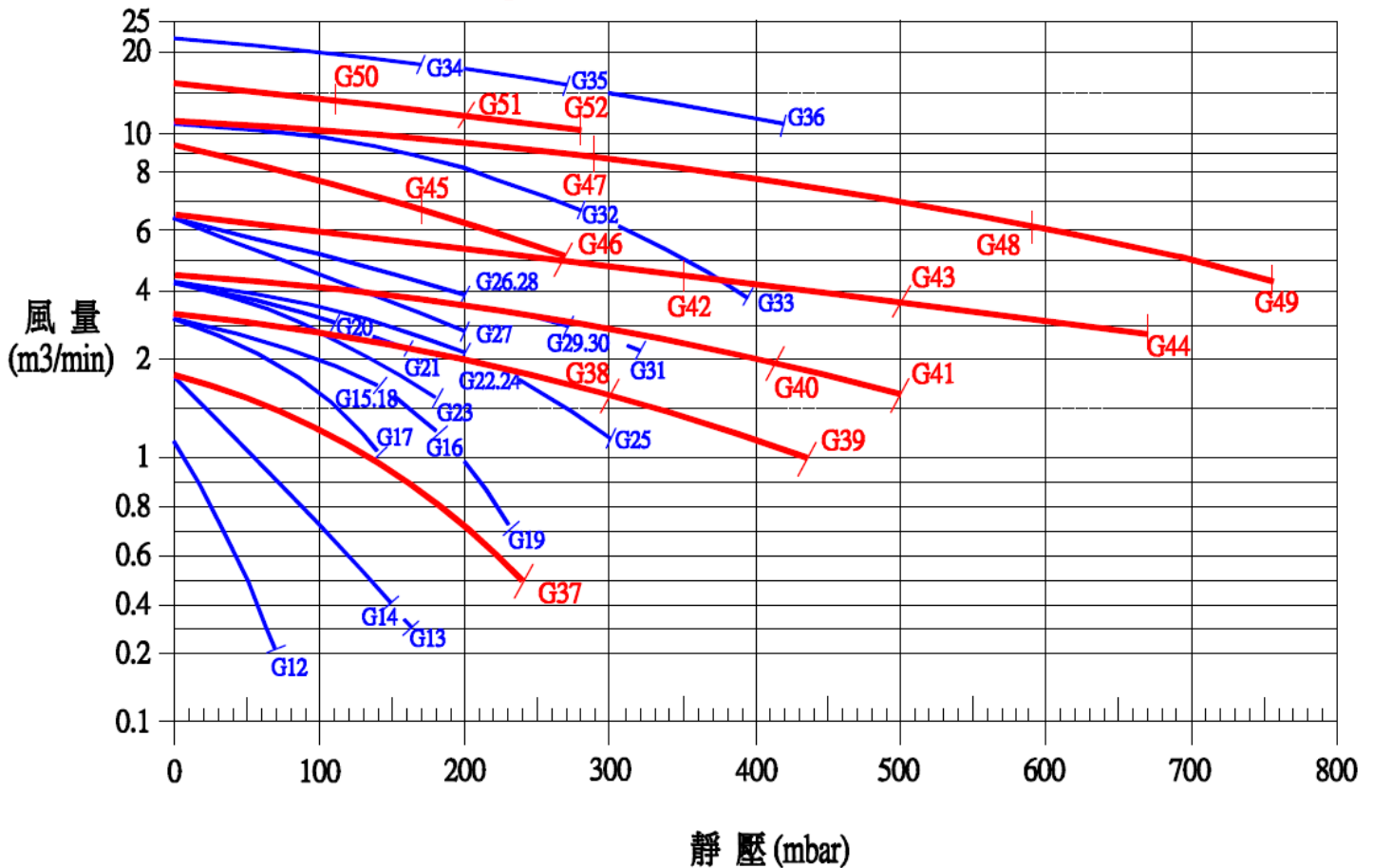

鼓風機之尺寸表(Dimensions)

DG-100 系列

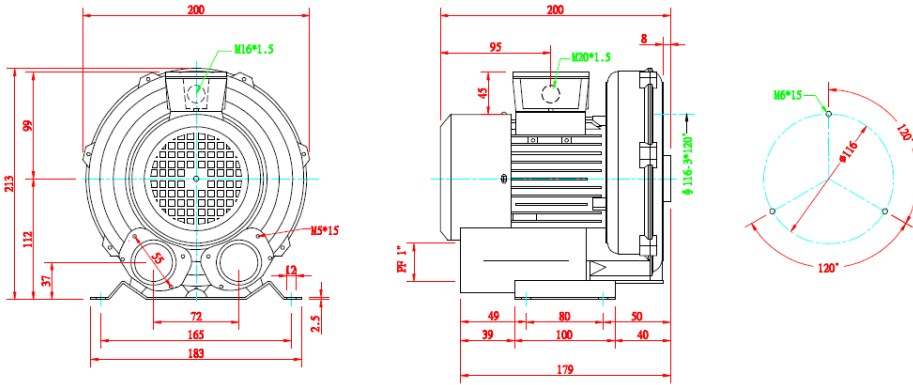

DG-200 系列

only DG-200 **W

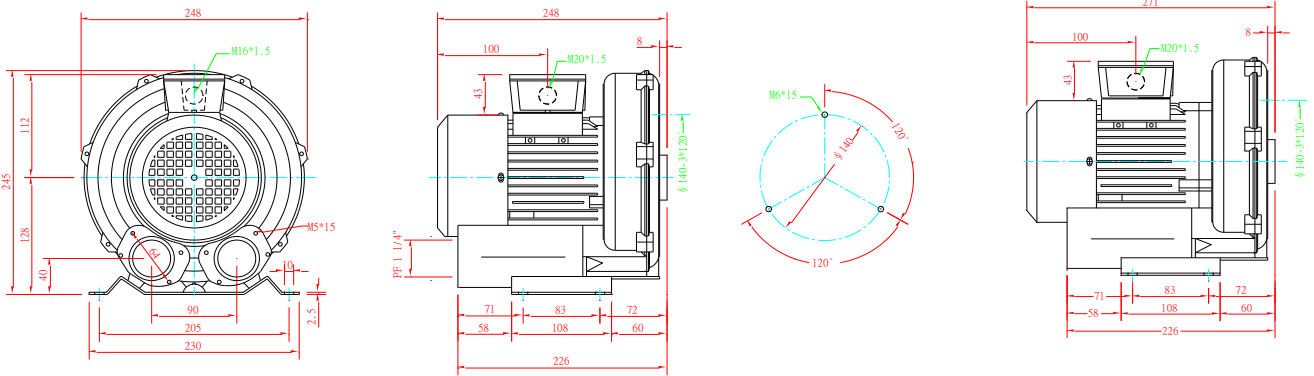

DG-300 系列

only DG-300 **W

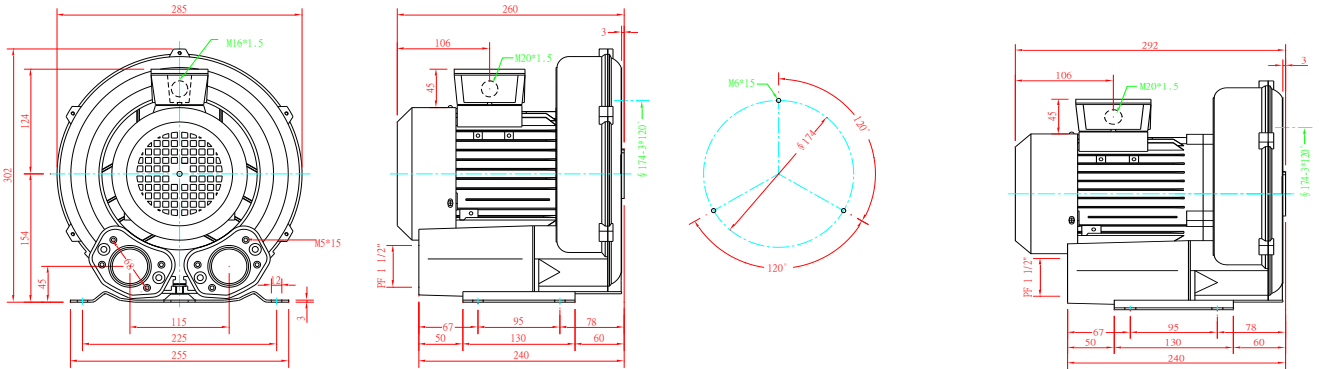

DG-400 系列

only DG-400 **W

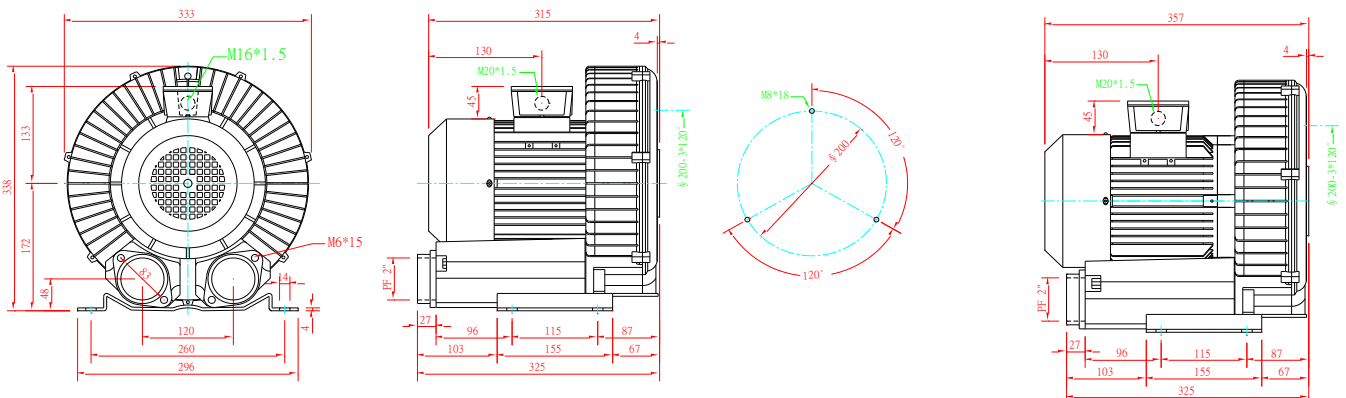

DG-600 系列

only DG-600 **W

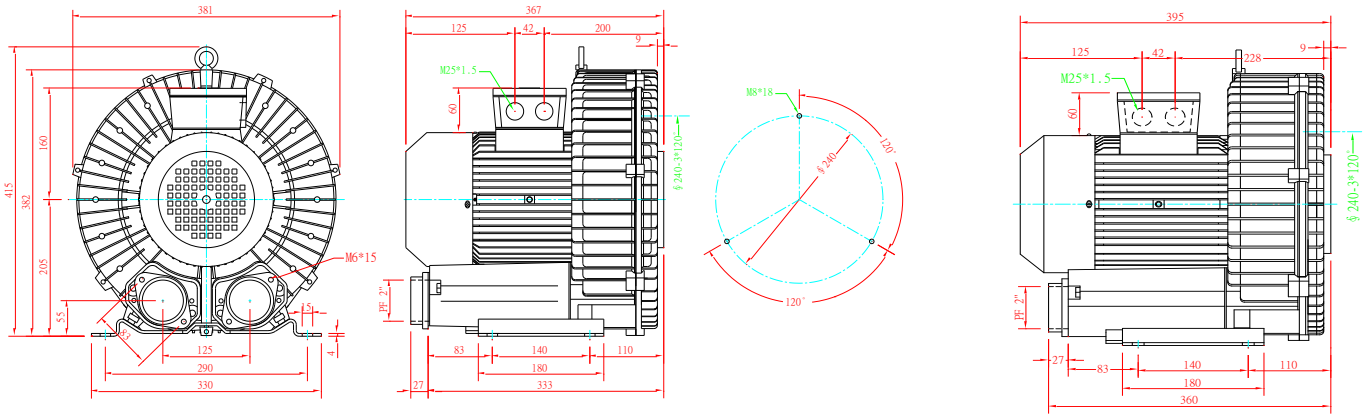

DG-800 系列

only DG-800 **W

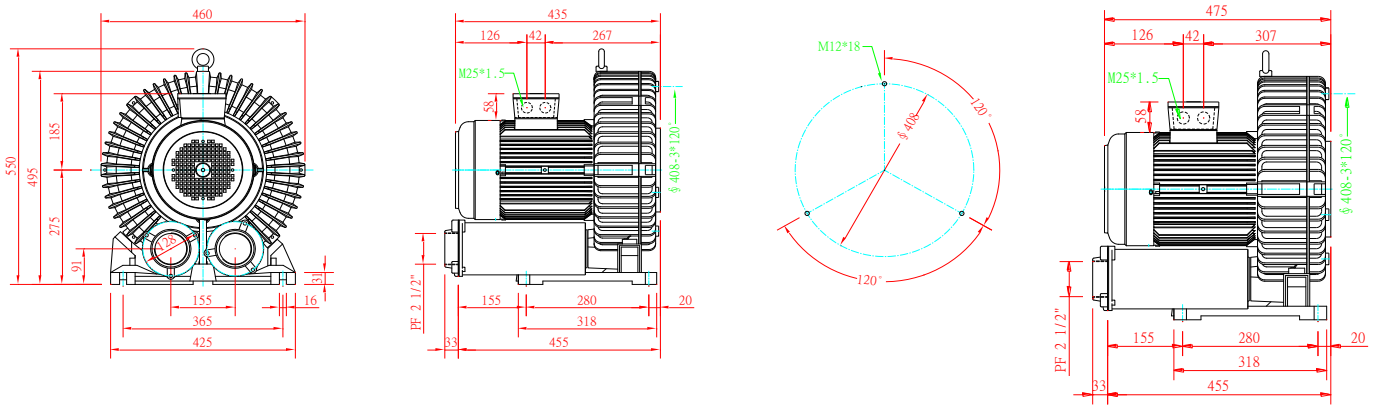

DG-900 系列

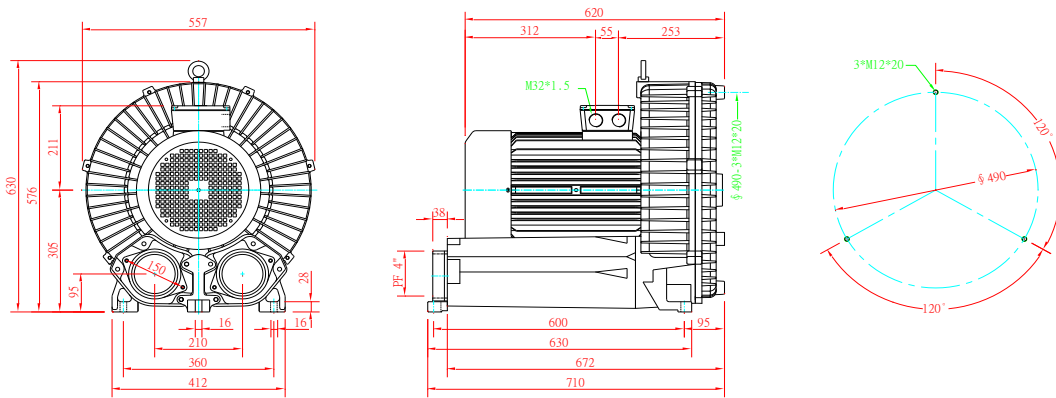

DG-230 系列

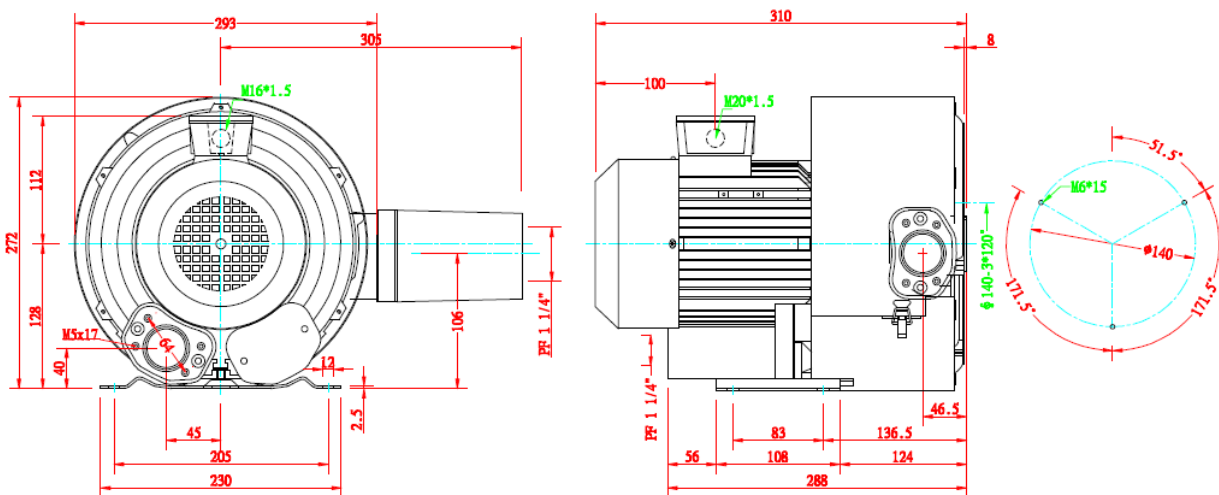

DG-330 系列

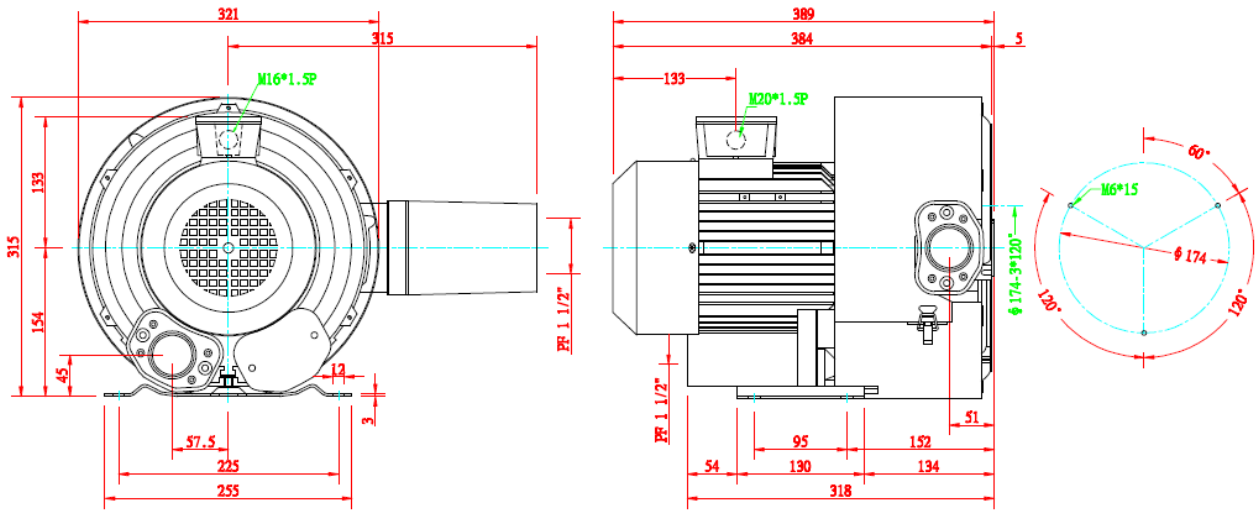

DG-430 系列

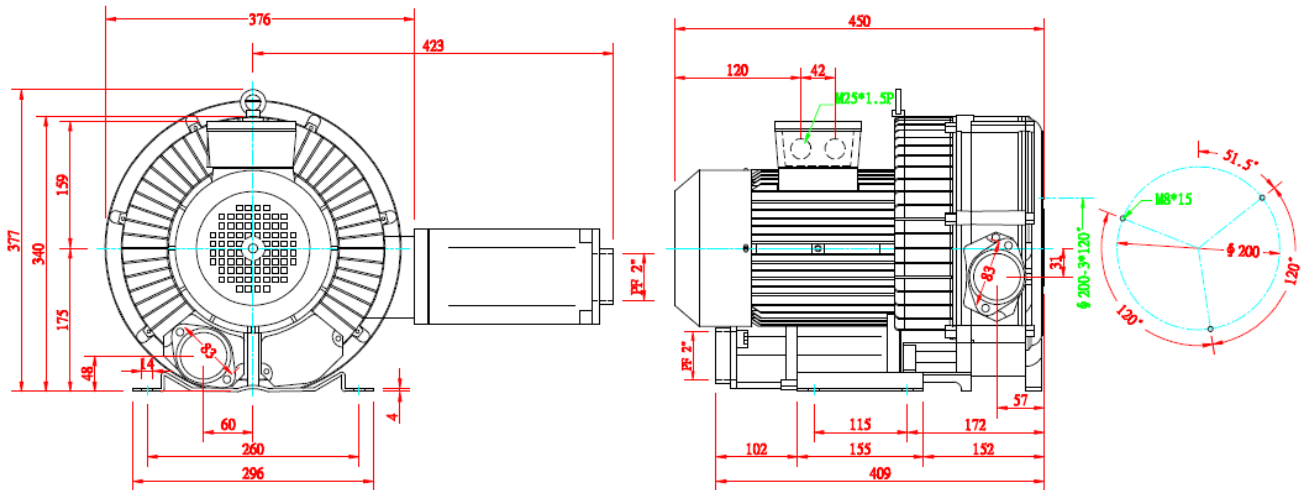

DG-630 系列

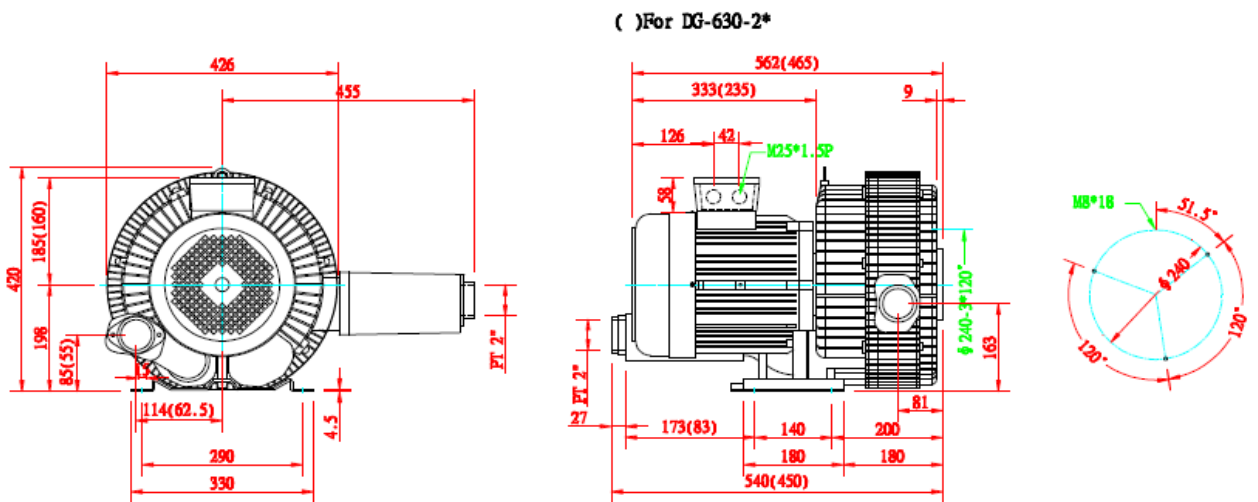

DG-640 系列

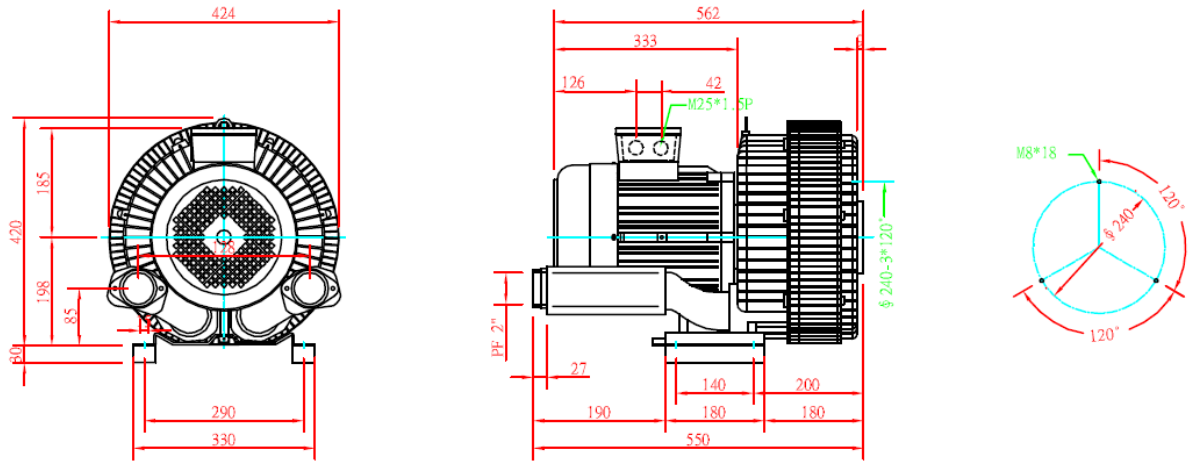

DG-830 系列

()For DG-830-1*

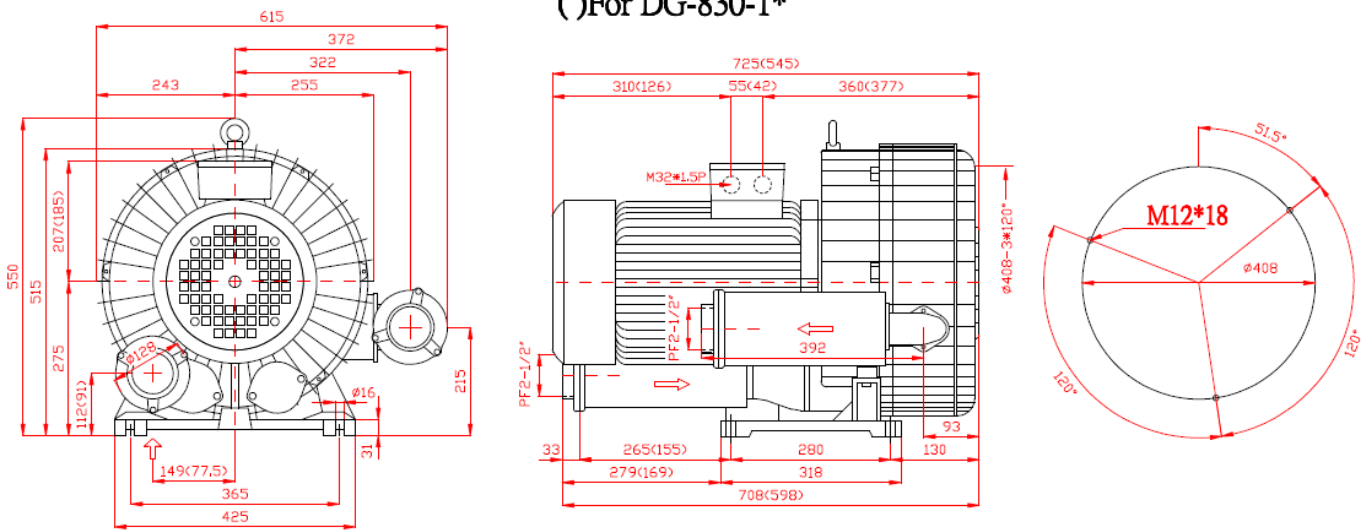

DG-840 系列

()For DG-840-1*

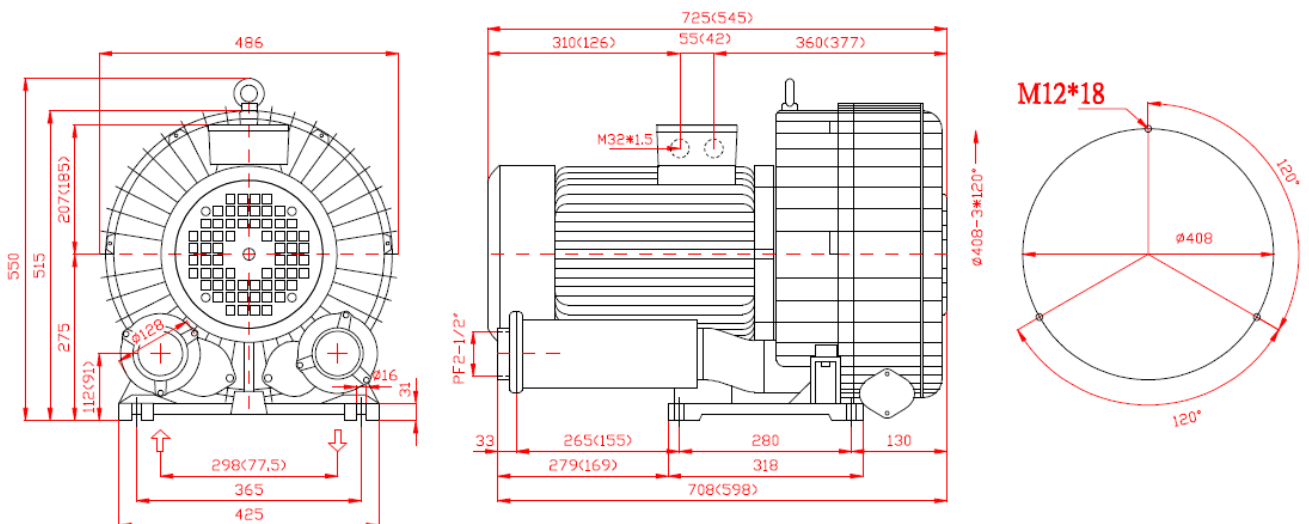

皮帶式(V-belt Blower)

單段式 (Single Stage)

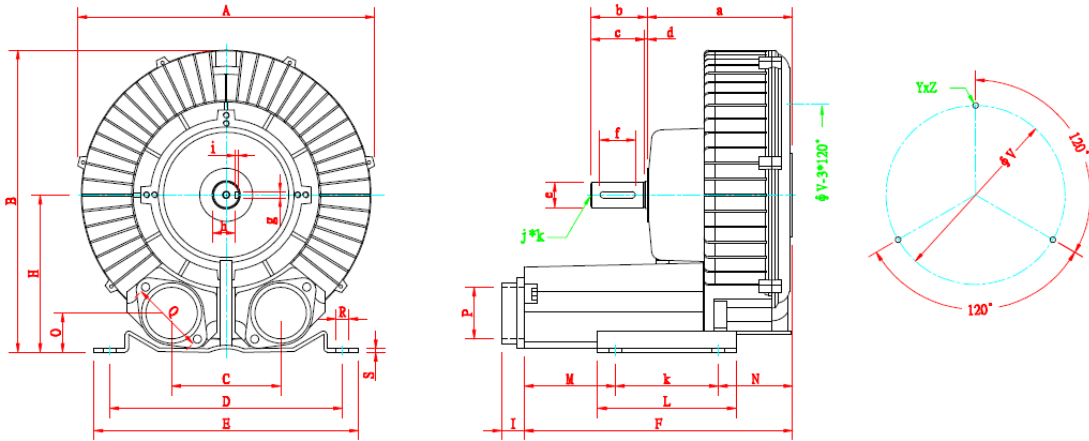

MODEL	A	B	C	D	E	F	H	I	K	L	M	N	O	P	Q
DG-200-0	248	245	90	205	230	226	128	-	83	108	71	72	40	PF 1 1/4"	64
DG-300-0	285	302	115	225	255	240	154	-	95	130	67	78	45	PF 1 1/2"	68
DG-400-0	333	338	120	260	296	298	172	27	115	155	96	87	48	PF 2"	83
DG-600-0	381	415	125	290	330	333	205	27	140	180	83	110	55	PF 2"	83
DG-800-0	460	550	155	365	425	455	275	33	280	318	155	20	91	PF 2 1/2"	φ 128
DG-900-0	557	630	210	360	412	672	305	38	600	630	-	95	95	PF 4"	150
MODEL	R	S	φ V	V-HOLE	Y*Z	a	b	c	d	e	f	g	h	i	j*k
DG-200-0	φ 10	2.5	φ 140	0°/120°/240°	M6*15	117	53	50	3	24	40	8	20	4	M8*20
DG-300-0	φ 12	3	φ 174	0°/120°/240°	M6*15	113	53	50	3	24	40	8	20	4	M8*20
DG-400-0	φ 14	4	φ 200	0°/120°/240°	M8*15	162.5	63	60	3	28	40	8	24	4	M8*20
DG-600-0	φ 15	4.5	φ 240	0°/120°/240°	M8*15	179.5	63	60	3	28	40	8	24	4	M8*20
DG-800-0	16	31	φ 408	0°/120°/240°	M12*15	268	83	80	3	42	60	10	38	4	M10*30
DG-900-0	16	28	φ 490	0°/120°/240°	M12*20	303.5	113	110	3	42	90	14	37.5	4.5	M10*30

雙段式 (Double Stage)

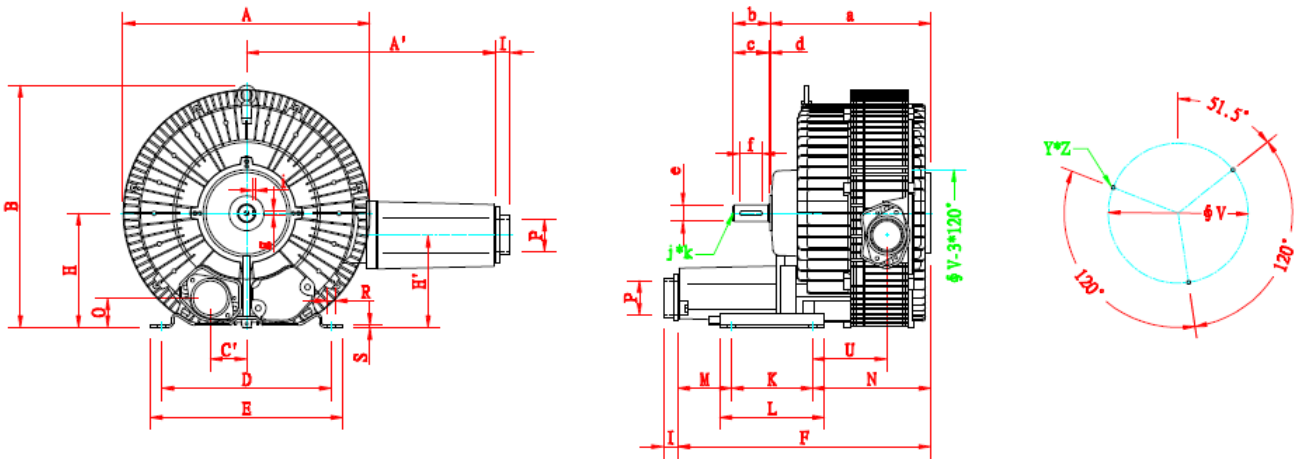

MODEL	A	A'	B	C'	D	E	F	H	H'	I	K	L	M	N	O	P	
DG-230-0	284	305	272	45	205	230	288	128	106	-	83	108	71	136.5	40	PF 1 1/4"	
DG-330-0	321	315	315	57.5	225	255	318	152	152	-	95	130	67	152	45	PF 1 1/2"	
DG-430-0	364	396	377	60	260	296	382	175	144	27	115	155	96	172	48	PF 2"	
DG-630-0	424	428	420	62.5	290	330	423	205	163	27	140	180	83	200	55	PF 2"	
DG-830-0	486	372	550	77.5	365	425	565	275	215	33	280	318	155	130	91	PF 2 1/2"	
MODEL	Q	R	S	U	φ V	V-HOLE	Y*Z	a	b	c	d	e	f	g	h	i	j*k
DG-230-0	64	φ 10	2.5	90	φ 140	51.5°/171.5°/291.5°	M6*15	180	53	50	3	24	40	8	20	4	M8*20
DG-330-0	68	φ 12	3	101	φ 174	60°/180°/300°	M6*15	189	53	50	3	24	40	8	20	4	M8*20
DG-430-0	83	φ 14	4	115	φ 200	51.5°/171.5°/291.5°	M8*15	248	63	60	3	28	40	8	24	4	M8*20
DG-630-0	83	φ 15	4.5	119	φ 240	51.5°/171.5°/291.5°	M8*15	275.5	63	60	3	28	40	8	24	4	M8*20
DG-830-0	φ 128	16	31	37	φ 408	51.5°/171.5°/291.5°	M12*15	376.5	83	80	3	42	60	10	38	4	M10*30

鼓風機之零件圖(Parts Illustration)

單段式(Single)

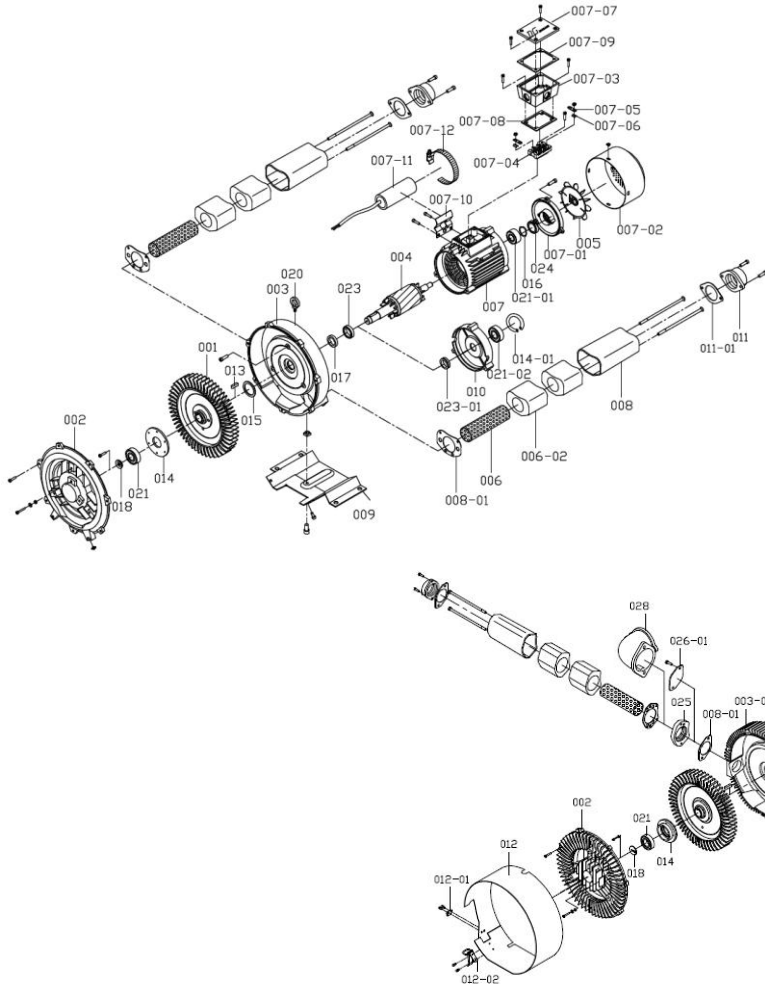

雙段式(Double stage)

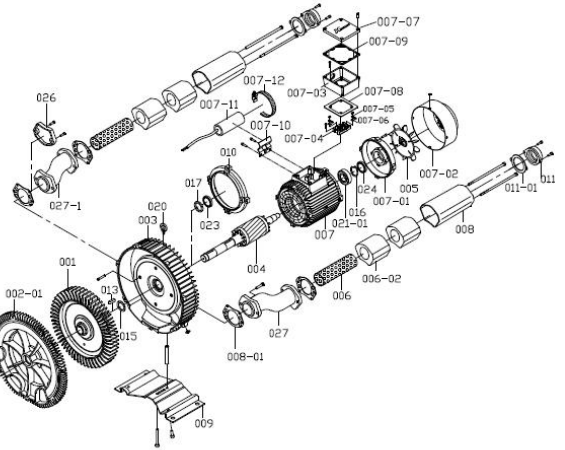

編號 ITEM	零件名稱 PARTS NAME	編號 ITEM	零件名稱 PARTS NAME	編號 ITEM	零件名稱 PARTS NAME
001	風葉 Impeller	007-08	配線盒墊片 Terminal box washer	015	風葉墊片 Washer
002	風蓋 Compressor cover	007-09	配線盒蓋墊片 Terminal cover washer	016	波浪墊片 Ware washer
002-01	中風蓋 Middle compressor cover	007-10	電容器固定片 Capacitor washer	017	羊毛氈 Cotton seal
003	風桶 Compressor housing	007-11	電容器 Capacitor	018	前軸承墊片 Washer
003-01	中風桶 Middle compressor housing	007-12	管束 Steel clip	020	吊環 Bronze ring
004	轉子 Rotor	008	腳管 Silencer housing	021	前軸承 Front bearing
005	散熱葉 Fan	008-01	腳管墊片 Silencer washer	021-01	後軸承 Rear bearing
006	消音鐵網 Silencer mesh pipe	009	腳座 Mounting plate	021-02	前軸承 Front bearing
006-02	消音海綿 Silencer sponge	010	馬達中蓋 Middle motor cover	023	前軸封 Front oil seal
007	馬達 Motor	011	牙口 Inlet/outlet	023-01	軸封 VA-seal
007-01	馬達後蓋 Motor cover	011-01	牙口墊片 Inlet/outlet washer	024	後軸封 Rear oil seal
007-02	散熱鐵蓋 Fan cover	012	外觀鐵片 Protection steel skin	025	腳管固定座 Silencer socket
007-03	配線盒 Terminal box	012-01	上箱扣 Buckle (up)	026	出口封蓋 Outlet cover
007-04	配線端子 Wire socket	012-02	下箱扣 Buckle (down)	026-01	封蓋 Cover
007-05	銅片 Wire connection slice	013	鍵 Rotor pin	027	彎管 Extend pipe
007-06	壓板 Fixed slice	014	前軸承固定片 Bearing washer	027-1	彎管 Extend pipe
007-07	配線盒蓋 Terminal cover	014-01	軸承 C 型扣環 Bearing washer	028	90°彎管 90°extend pipe

* 訂購時請告知型號+零件編號 (例如:DG-600-26+002)

* Please notify model+parts item when you purchase.

*本公司保有設計變更之權利，恕不另行通知。

*We reserve the right to change the design without notice.

鼓風機配件表(Accessories)

釋壓閥 / Pressure Relief Valve

型號 Type	口徑/PF Dimension	L (mm)	規格 Dimension
RV-01	1 1/4"	142	0~3000mmAq
RV-02	1 1/4"	142	0~6000mmAq

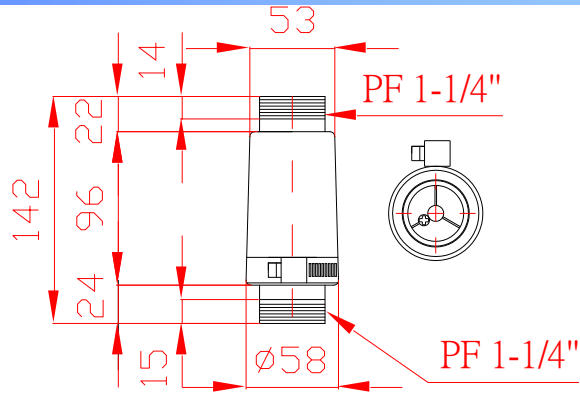

三通管 / Tee Pipe (mm)

型號 Type	適用機型 Application
TP-01	DG-200,230,300,330 系列(Serial)
TP-02	DG-400,430,600,630,640 系列(Serial)

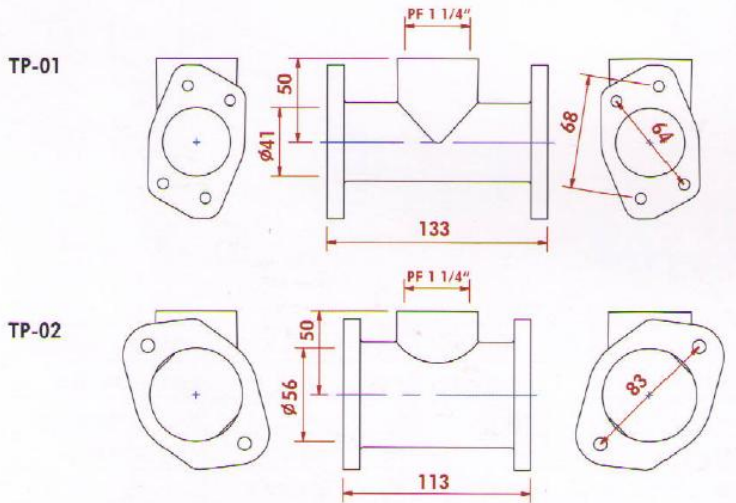

TP-01

TP-02

MF 型過濾器 / MF Type Suction Filter

符號 Symbol 型號 Type	口徑 PT	D (mm)	L (mm)	H (mm)	B (mm)	過濾精度(目) Filtration mesh	重量(kg) Weight
MF-08	1"	58	170	155	42	100	0.20
MF-10	1 1/4"	71	186	170	54	100	0.35
MF-12	1 1/2"	85	196	182	65	100	0.49
MF-16	2"	103	215	202	75	100	0.65
MF-20	2 1/2"	148	274	252	97	100	1.20
MF-32	4"	208	380	357	142	100	2.45

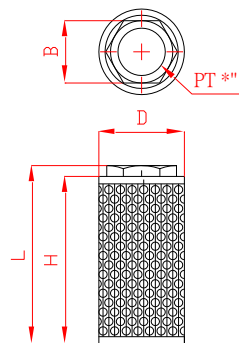

鼓風機配件表(Accessories)

消音器

符號 Symbol 型號 Type	A	B (mm)	C (mm)
SI-01	PF 1 1/4"	83	180
SI-02	PF 1 1/2"	98	180
SI-03	PF 2"	117	266
SI-04	PF 2 1/2"	145	325

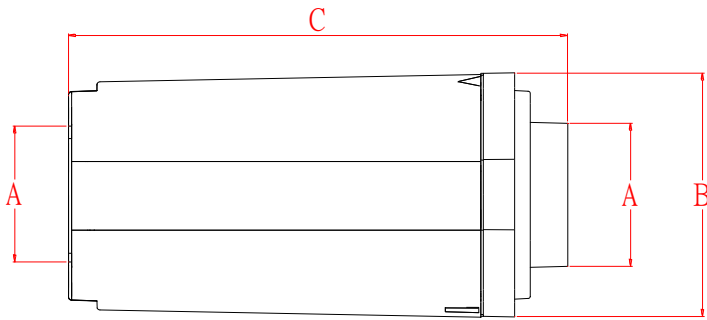

牙口/Threaded Flange[mm]

符號 Symbol 型號 Type	A	B	C	D	E	F
2-011	PF 1 1/4"	7	22	64	79	6
3-011	PF 1 1/2"	7	24	68	86	6
6-011	PF 2"	7	18	83	100	7
8-011	PF 2 1/2"	15	16	Ø128	144	7
9-011	PF 4"	8	22	150	170	9

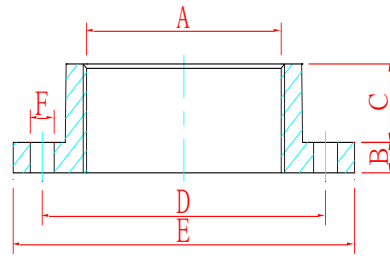

防震腳墊供垂直或水平安裝

Footprint dimensions for vertical/horizontal mounting[mm]

型號 Type	D	H	G	L
MFB2520	25	20	M6	12
MFB3025	30	25	M8	15
MFB7540	75	40	M12	20
MFB7545	75	45	M12	37

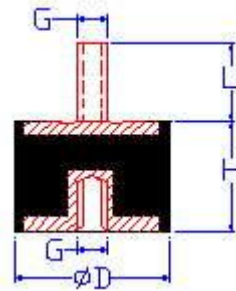

附註: 若需要其他配件, 請與本公司或經銷商連絡

If you need other accessories, please contact us or distributors.