

型号说明 示例: T7BS-B10-1R00-A1M1 - T6C-025-1R00-C1

1. **T7BS-B10-1R00-A1M1** 系列号

SAE 安装	T7BS	T6C	T6D	T6E
公制安装	T7B	-	-	-

2. **T7BS-B10-1R00-A1M1** 泵芯规格

B	C	D	E
B02..... 5.8	003..... 10.8	B14..... 44.0	042..... 132.3
B03..... 9.8	005..... 17.2	B17..... 55.0	045..... 142.4
B04..... 12.8	006..... 21.3	B20..... 66.0	050..... 158.5
B05..... 15.9	008..... 26.4	B22..... 70.3	052..... 164.8
B06..... 19.8	010..... 34.1	B24..... 81.1	057..... 179.8
B07..... 22.5	012..... 37.1	B28..... 90.0	062..... 196.7
B08..... 24.9	014..... 46.0	B31..... 99.2	066..... 213.3
B10..... 31.8	017..... 58.3	B35..... 113.4	072..... 227.1
B12..... 41.0	020..... 63.8	B38..... 120.6	085..... 269.0
B15..... 50.0	022..... 70.3	B42..... 137.5	
	025..... 79.3	045..... 145.7	
	028..... 88.8	050..... 158.0	
	031..... 100.0		

3. **T7BS-B10-1R00-A1M1** 轴伸形式

T7BS-B10-1R00-A1M1 转向

顺时针	R
逆时针	L

4. **T7BS-B10-1R00-A1M1** 油口布置

5. **T7BS-B10-1R00-A1M1** 设计号

6. **T7BS-B10-1R00-A1M1** 密封等级

丁腈橡胶: 矿物油	1
氟橡胶: 矿物油和阻燃液压油	5

7. **T7BS-B10-1R00-A1M1** 安装连接

		口螺纹	公制螺纹	UNC 螺纹
T7B	S = 1 1/2"	P = 3/4"	M1	-
		P = 1"	M0	-
T7BS	S = 1 1/2"	P = 3/4"	M1	01
		P = 1"	M0	00
T6C	S = 1 1/2"	P = 1"	无选项	无选项
T6D	S = 2"	P = 1 1/4"	无选项	无选项
T6E	S = 3"	P = 1 1/2"	无选项	无选项

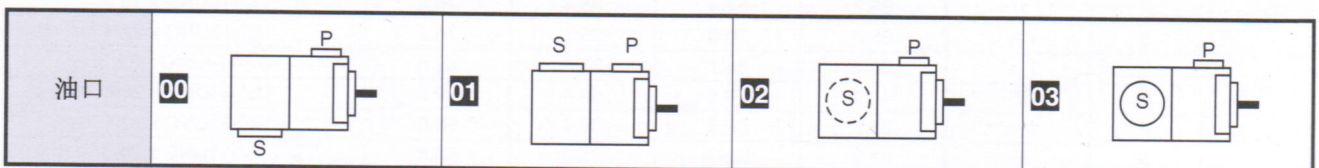

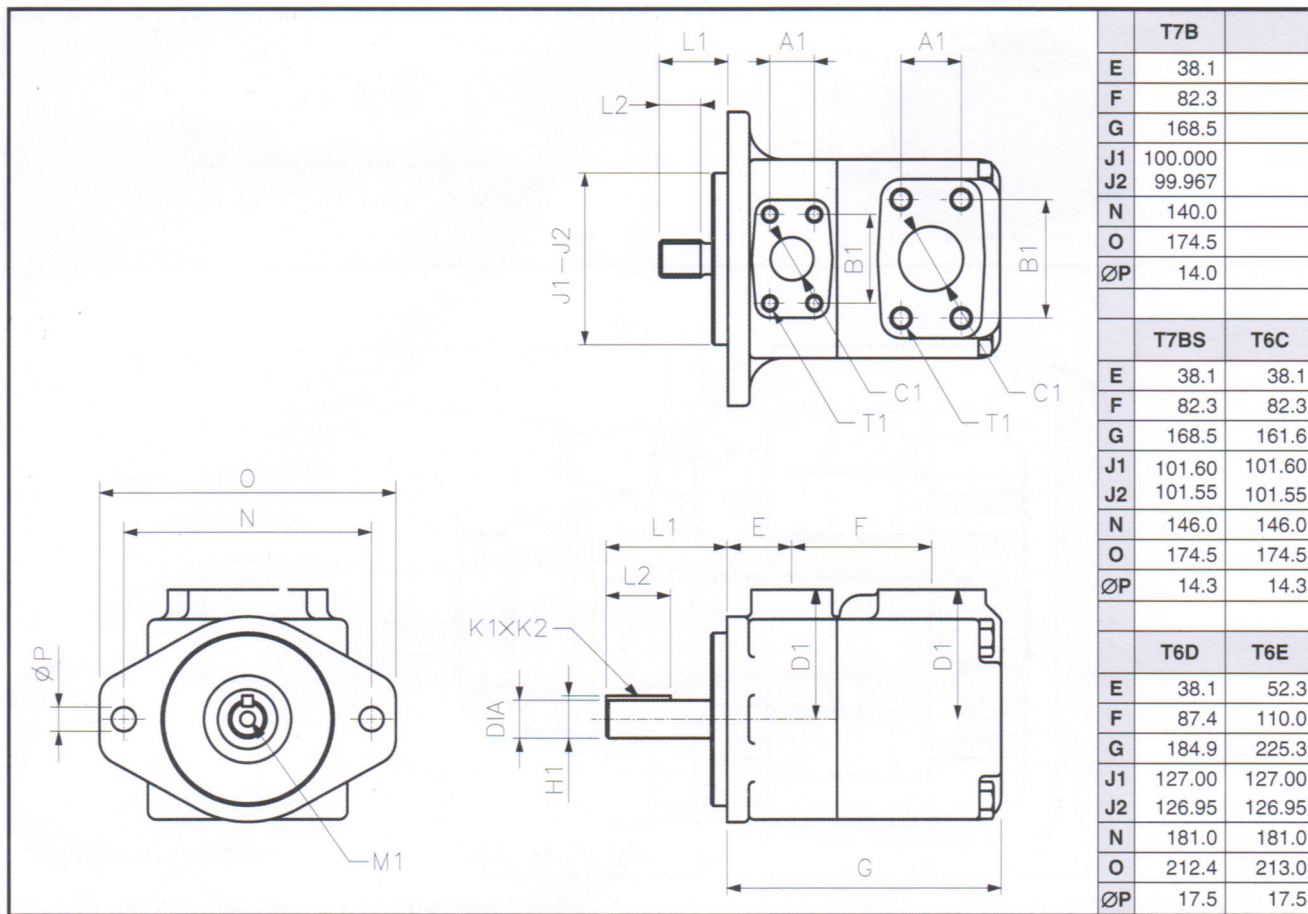

轴伸	最大扭矩 (N.m)					安装尺寸 (mm)					
	T7B	T7BS	T6C	T6D	T6E	L1	L2	直径	K1 x K2	H1	M1
1	平键: SAE B (Ø22)	●	275			71.4	38.1	22.225 - 22.200	6.35 x 6.30	24.95	M8 x 16
	平键: SAE C (Ø31)			●		83.6	49.3	31.750 - 31.700	7.94 x 7.89	35.27	M10 x 20
	平键: SAE CC (Ø38)				●	90.9	50.8	38.100 - 38.050	9.52 x 9.47	42.36	M10 x 20
2	平键: 非 SAE (Ø22)		238			58.2	31.7	22.225 - 22.200	4.76 x 4.71	24.53	-
	平键: ISO R775 (Ø25)	●				70.0	40.0	24.9935-25.0065	8.00 x 7.00	28.22	-
	平键: 非 SAE (Ø31)			577		73.2	38.1	31.750 - 31.700	7.94 x 7.89	35.27	-
	平键: 非 SAE (Ø31)				577	61.9	38.1	31.750 - 31.700	7.94 x 7.89	35.27	-
3	花键: SAE B	●	343			40.7	24.5	SAE J498b 1 级, 径节 16/32, 13 牙			-
	花键: SAE C			●	●	55.2	38.0	SAE J498b 1 级, 径节 12/24, 14 牙			-
4	花键: SAE BB	●	●			45.5	24.5	SAE J498b 1 级, 径节 16/32, 15 牙			-
	花键: 非 SAE			●		77.7	48.0	SAE J498b 1 级, 径节 12/24, 14 牙			-
	花键: SAE CC				●	62.2	31.5	SAE J498b 1 级, 径节 12/24, 17 牙			-

油口			安装尺寸 (mm)				
			A1	B1	ØC1	D1	T1 口螺纹
T7BS	P	01: ¾" 00: 1"	22.2 26.2	47.7 52.4	19.0 25.4	76.2	¾"-16UNC x 19.0
	S	1 ½"	35.8	70.0	38.1	76.2	½"-13UNC x 22.4
T7B	P	M1: ¾" M0: 1"	22.2 26.2	47.7 52.4	19.0 25.4	76.2	M10 x 19.0
	S	1 ½"	35.8	70.0	38.1	76.2	M12 x 22.4
T6C	P	1"	26.2	52.4	25.4	76.2	¾"-16UNC x 19.0
	S	1 ½"	35.8	70.0	38.1	76.2	½"-13UNC x 22.4
T6D	P	1 ¼"	30.2	58.7	31.8	82.6	7/16"-14UNC x 22.3
	S	2"	42.9	77.8	50.8	82.6	½"-13UNC x 23.9
T6E	P	1 ½"	35.7	69.8	37.1	98.6	½"-13UNC x 23.4
	S	3"	61.9	106.4	75.0	98.6	5/8"-11UNC x 24.0